

Standard Gain Horn

170 to 260 GHz, WR04, 26 dBi Gain

DESCRIPTION

Anteral's Standard Gain Horns are high performance antennas designed to exhibit smooth gain response in the whole band and very low VSWR. The antenna exterior appearances are designed to minimize weight, improve robustness and offer a sharp aperture. They are manufactured from a single aluminum rod. No soldering for flanges and no screws for attaching parts are included.

The SGH-26-WR04 model operates between 170 and 260 GHz with 26 dBi nominal mid-band gain and a typical VSWR of 1.1.

APPLICATIONS

This type of horns is especially suitable for laboratory test measurements, electromagnetic measurements and gain calibration. Moreover, custom bands and gain values can be requested.

Anteral also offers their **Lens Horn Antennas** with plano-convex Teflon (PTFE) lenses to exhibit high gain (>30 dBi) with minimum size.

ELECTRICAL SPECIFICATIONS

Parameter	Typical value
Frequency	170 - 260 GHz
Directivity	26 dBi
3 dB Beamwidth, E-plane	7.7 deg
3 dB Beamwidth, H-plane	8.5 deg
Sidelobe, E-plane	-10 dB
Sidelobe, H-plane	-33 dB
S11	-25 dB

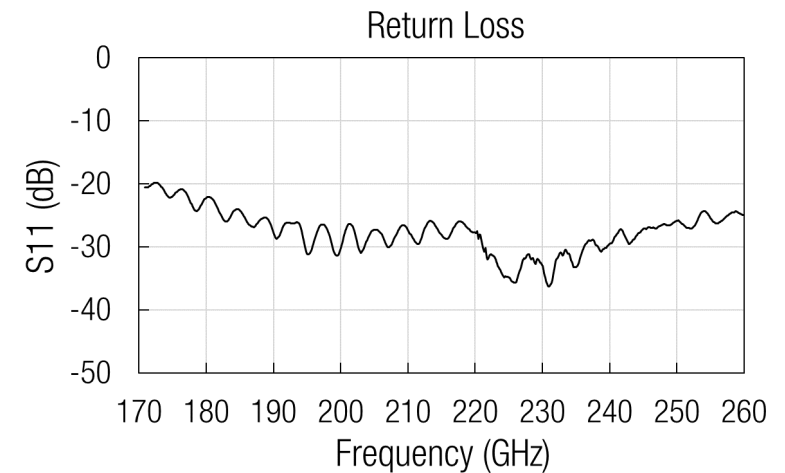
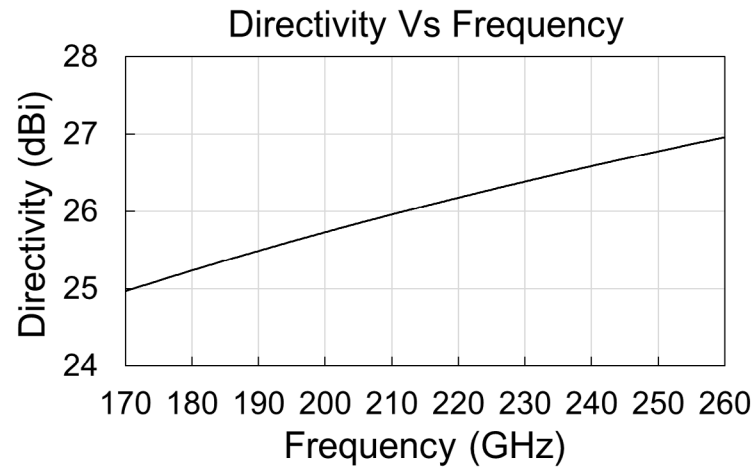
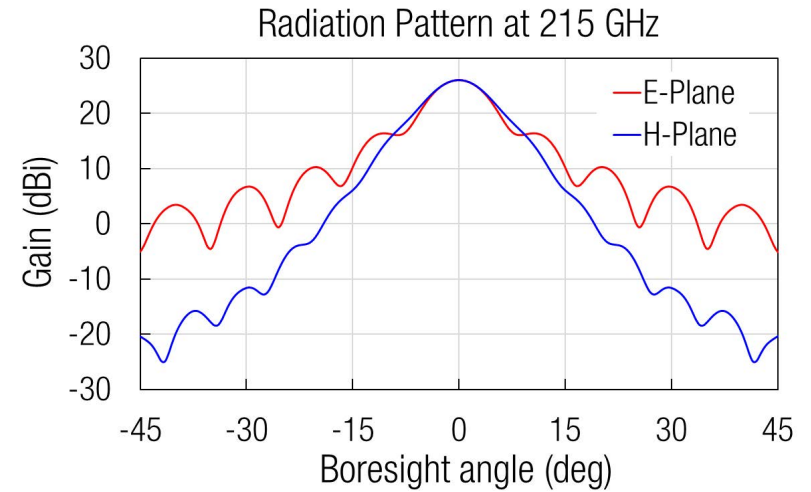

MECHANICAL SPECIFICATIONS

Parameter	Description
Antenna Port	WR-4.3 (1.092 mm x 0.546 mm)
Flange	UG-387/U
Length	34.4 mm
Total weight	7 g
Material	Aluminum
External Color	Ruby Red

MECHANICAL OUTLINE

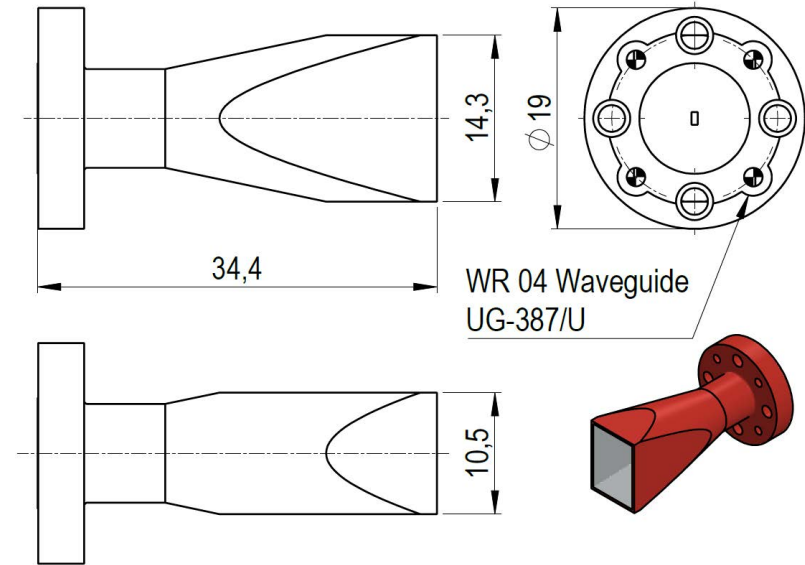

Additional notes

Directivity and radiation pattern data are simulated. Return loss data are measured from a sample. Actual values could vary slightly.
The return loss performance of all items is checked before delivery.

