

Ka-Band Near Field Probe

26.5 to 40 GHz, WR28

DESCRIPTION

The NFP-100-WR28 is a high-performance open-ended waveguide probe that operates at the X-band between 26.5 and 40 GHz. It is manufactured from a single aluminium rod by high accurate manufacturing processes. The opening is sharp to reduce/minimize reflections.

Under client request, all NFPs can include adequate absorber material to reduce backscattering reflections from flanges.

APPLICATIONS

This type of probes is especially suitable for laboratory antenna near field measurements. Moreover, custom bands and radiation pattern data can be requested for probe correction purposes.

Anteral also offers their **CATR** (Compact Antennas Test Range) for measuring antennas at such antenna test facilities.

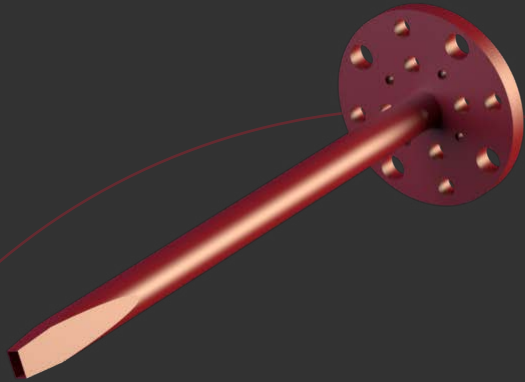

ELECTRICAL SPECIFICATIONS

Parameter	Typical value
Frequency	26.5 - 40 GHz
Directivity	6.5 dBi
S11	-13 dB

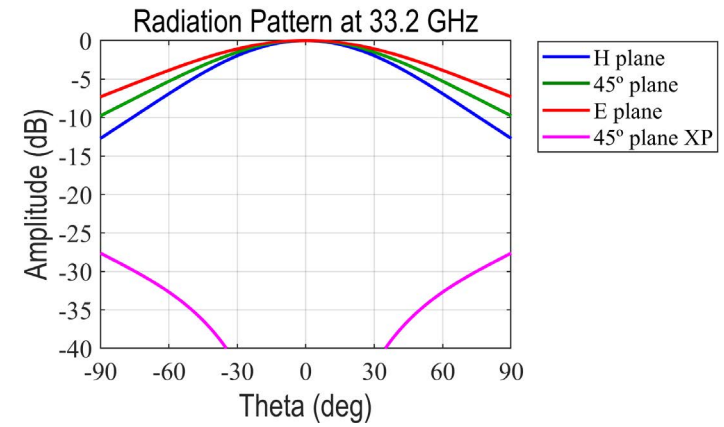
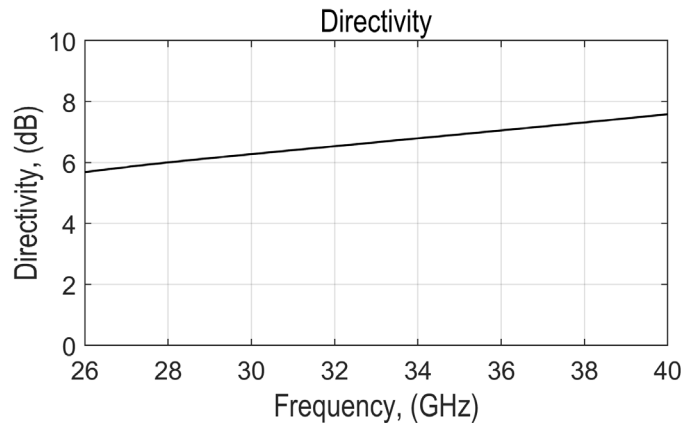
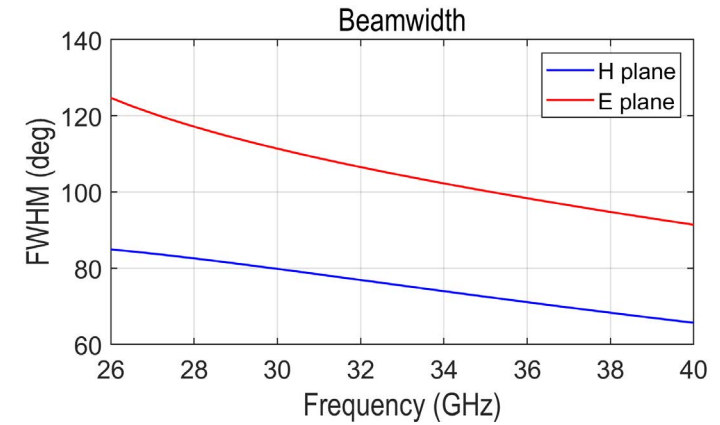

MECHANICAL SPECIFICATIONS

Parameter	Description
Antenna Port	WR-28 (7.112 mm x 3.556 mm)
Flange	UG-599/U -PF
Total length	100 mm
Horn Material	Aluminum

MECHANICAL OUTLINE

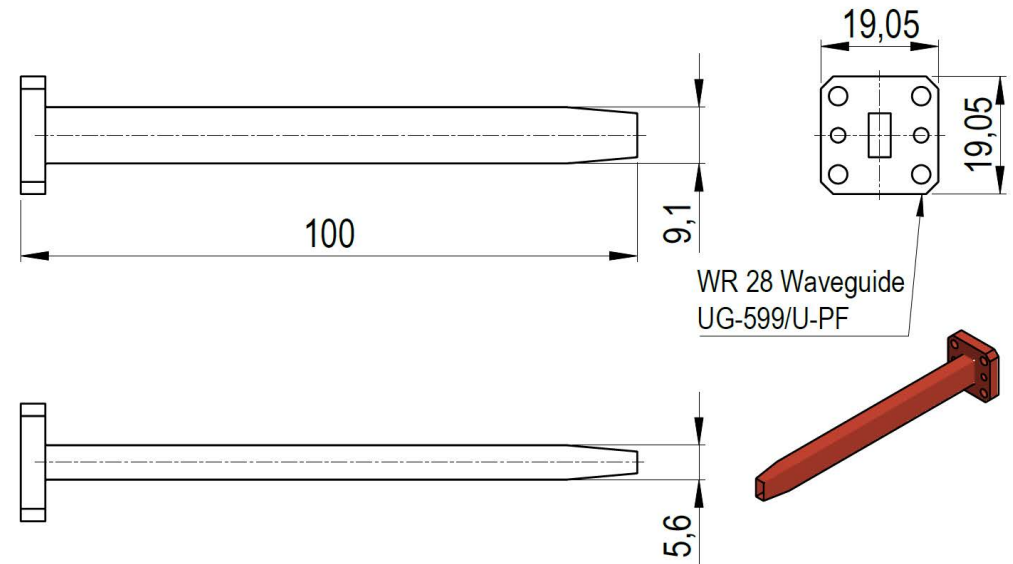

Additional notes

The return loss performance of all items is checked before delivery.

Last version: 09/05/2022.

