

Update 2021-07-03

PHASE ADJUSTERS 2021



DC to 63 GHz



80905 Munich, Germany P.O. Box 450533

Telephone: +49-89-3548-040

Facsimile: +49-89-3548-0490

WWW.SPECTRUM-ET.COM * Email: sales@spectrum-et.com

PHASE ADJUSTERS 2021



Spectrum Elektrotechnik GmbH is a leading manufacturer of RF and Microwave Components in the Frequency Range of DC to 71 GHz. The products are published in individual catalogs, showing detailed information and comprehensive data.

Adapters, DC - 71 GHz, 50 Ohms
 Coaxial Adapters (In Series and Between Series)
 Hermetically Sealed Adapters
 High Power Adapters
 Push-On Adapters
 Waveguide to Coax Adapters

Connectors, DC - 71 GHz, 50 Ohms
 Blind Mate Connectors
 Coaxial Connectors
 High Power Connectors
 Multi Pin Connectors
 Push-On Connectors

Cable Assemblies, DC - 71 GHz, 50 Ohms
 ANA Test Cables
 Flexible Cable Assemblies
 Low Loss Cable Assemblies
 Phase Stable Cable Assemblies
 Semi Rigid Cable Assemblies (Dia. 0.34" to 1")

Test Necessities & Accessories, DC - 71 GHz, 50 Ohms
 LRL, TRL Calibration and Verification Kits
 ANA Cable Assemblies
 Torque Wrenches
 Interface Gauges
 Calibration Kits
 Terminations

Components, DC - 71 GHz, 50 Ohms
 Attenuators
 Circulators
 Custom Components
 DC-Blocks
 Gain-Equalizers
 Isolators
 Limiters
 Mismatches
 Phase Shifters
 Terminations
 Waveguide Components



Multipin/Multiport Connectors, DC-40 GHz, 50 Ohms
 BQ-Series
 CQ-Series
 IQ-Series
 RQ-Connector
 SQ-8-Connector
 TQ-Series

Phase Adjusters, DC - 63 GHz, 50 Ohms
 Phase Adjustable Connectors
 Phase Adjustable Adapters

Quick Connections, 50 Ohms
 Blind Mate Connectors
 Push - On Adapters
 Push - On Connectors
 Push - On Cable Assemblies

High Power Duplexers

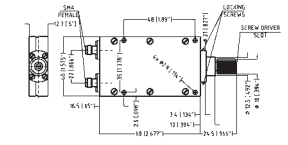
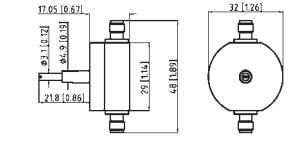
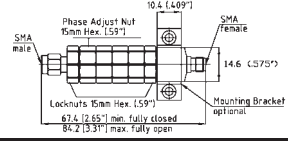
Adjusting Phase.indd.2014

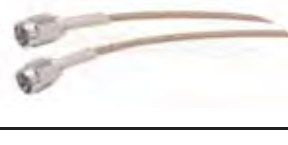
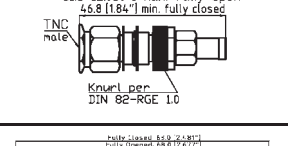
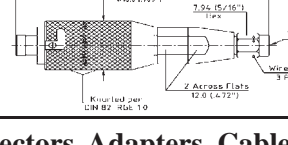
Type	Section	Subject	Content	Page
Phase Adjusting Products	A	Overview Phase Adjustable Products		A
	B	Phase Adjusters in rectangular Housing		B
	C	Phase Adjusters in Stripline Design		C
	D	Coaxial Phase Adjustable Adapters		D
	E	Phase Adjustable Trombone Lines		E
	F	Phase Matching Cable Assemblies		F
	G	Factory Phase Adjustable Connectors		G
	H	Customer Phase Adjustable Connectors		H
	I	Our other Products	Connectors, Adapters, Cable Assemblies, Delay Lines, Duplexers, Multiport Connectors, Test Necessities, Catalogs	I
	K	Our Representatives Terms & Conditions Our Catalogs	Our world wide Representatives Our Catalogs	K

Adjusting Phase.indd.2014

INTRODUCTION: The Precision Phase Shifters, or Phase Adjusters allow the adjustment of the electrical separation between components. A precision mechanical movement provides for smooth and accurate adjustment over the entire frequency range. A secure locking mechanism is furnished with every unit. A wide selection of components is available, offering different mechanical configuration, frequency range, electrical length, and/or connector configuration.

Phase Adjustment: The Phase Shifters are mechanical devices, therefore the change of phase depends on the adjustment of the electrical length of a line. For lower frequencies or longer phase adjustments, a trombone line is usually used; for higher frequencies or shorter adjustment, only a straight line may be sufficient. Using an air line results in low insertion loss and good VSWR. The designs of Spectrum Elektrotechnik GmbH employ air lines, whenever possible.

Frequency Range: Phase Adjusters are available for different frequency ranges, DC-2.0 GHz, DC-12.4 GHz, DC-18.0 GHz, DC-26.5 GHz, DC-40.0 GHz, DC-50.0 GHz, and DC-65.0 GHz. For economical reasons the components have been engineered for these different frequency bands. A rather simple design will meet all the requirements at lower frequency ranges, while only a most precise design will work satisfactorily at highest frequencies.

Connector Configuration: Most of the Phase Adjusters of Spectrum Elektrotechnik GmbH are available with different connector configurations, providing that the frequency range of the connectors do not limit the frequency range of the application. The flatpack phase adjusters can be supplied with 7mm, SMA, N, and TNC, males and females, as standard. Besides the units being supplied with connectors, using the same style but different sex at input and output, it is even possible to have a unit being supplied with connectors of completely different connector styles, e.g. N female as an input connector and SMA male as the output connector, etc.

The Adjustable Adapters and Components, serving to 26.5 GHz are offered with SMA connectors, and are available with male or female connectors at the in- and output or vice versa. With 40.0 GHz usually 2.92 mm connectors will be used, and with 50.0 GHz the 2.4mm connectors have been chosen. The ones that work up to 65.0 GHz are assembled with 1.85mm connectors.

Applications: Phase Adjusters will mostly be needed in systems where the adjustment of the phase is done for only a few times. As soon as the phase is set properly as needed in the system, the unit will usually be locked, and remain in this position. In other applications the phase shifters are installed in test sets where the adjustment of phase is made continuously. For these applications, only the Phase Adjusters using ball bearing support and special mechanisms can be recommended.

VSWR: Every microwave component shows reflections and discontinuities within the circuit, as no design can be perfect, and manufacturing tolerances unfortunately do not allow theoretical results. VSWR is the ratio of the reflected signal and the incident signal. Phase Shifters are using a high number of parts. Therefore, the tolerances on the dimensions of the piece parts need to be as tight as possible not only for mechanical purposes, but also for electrical reasons, in order to assure that reflections cannot build up after some time of operation.

Power: The standard components are designed for low or moderate power applications. For higher power applications, units can be supplied as specials, engineered exactly to the customer's needs.

Custom Units: Although Spectrum Elektrotechnik GmbH offers a wide variety of standard phase adjusters, there will always be a need for a special component, using different mechanical configuration, wider phase adjustment, other frequency ranges, etc. Spectrum Elektrotechnik GmbH is a very innovative Company. It employs a strong and successful team of experienced engineers. They will always do their best to propose something that will perfectly fit the customer's needs.

Phase Adjuster Life: The life expectancy of a unit will depend in the first place on the operating environment versus unit design. Secondly, it will depend on the lifetime of the ball bearings, seals and contact junctions. Other parameters that are limiting life are rotational speed and external mechanical loading, or pressurizing the unit. Harsh environment, subjecting the component to vibrations, shock, extremely low or high temperatures, humidity, etc. may further shorten the lifetime. It is therefore of utmost importance to identify in detail the environment the device is supposed to operate in.

If the unit is installed in a system where the phase only will be adjusted a few times, it would not be necessary to select a device that is using ball bearings in the design, vice versa will a phase adjuster cause trouble in an environment where it is constantly adjusted, when not the appropriate mechanical design will be used.

Spectrum Elektrotechnik GmbH has a large number of available designs. Please take the time to decide on the unit that fits exactly your requirements.

Adjusting Phase.indd.2014

1. Phase Adjusters in rectangular Housings

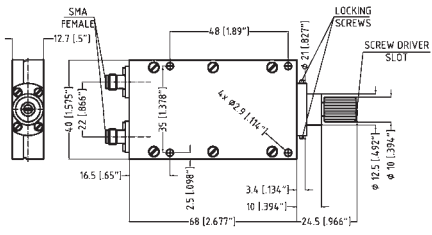
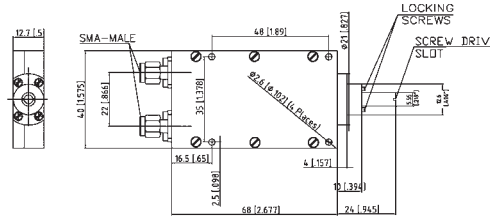
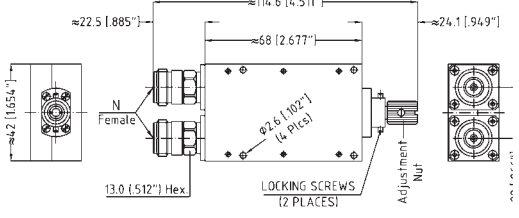
Frequency Range (GHz)	Features	Outline	Page
DC - 2.0 DC - 12.0 DC - 18.0	Phase Adjuster with axial locking . Series LS-00XX-YYZZ XX: Frequency range XX=02; DC to 2 GHz XX=12 DC to 12 GHz XX=18 DC to 18 GHz Connectors YY & ZZ: 7mm = 90 N male = 51 N female = 61 TNC male= 31 TNC female = 41 SMA male = 11 SMA female = 21		B2 ff
DC - 2.0 DC - 12.0 DC - 18.0	Phase Adjuster with in line locking . Series LS-01XX-YYZZ XX: Frequency range XX=02; DC to 2 GHz XX=12 DC to 12 GHz XX=18 DC to 18 GHz Connectors YY & ZZ: 7mm = 90 N male = 51 N female = 61 TNC male= 31 TNC female = 41 SMA male = 11 SMA female = 21		B4 ff
DC - 2.0 DC - 12.0 DC - 18.0	Phase Adjuster using Ball Bearing Adjustment Series LS-B0XX-YYZZ XX: Frequency range XX=02; DC to 2 GHz XX=12 DC to 12 GHz XX=18 DC to 18 GHz Connectors YY & ZZ: 7mm = 90 N male = 51 N female = 61 TNC male= 31 TNC female = 41 SMA male = 11 SMA female = 21		B6 ff

Adjusting Phase.indd.2014

1. Phase Adjusters in rectangular and round Housings			
Page	Frequency Range (GHz)	Features	Outline
B8 ff	DC - 2.0 DC - 12.0 DC - 18.0	Phase Adjuster with Micrometer Adjustment Series LS-M0XX-YYZZ XX: Frequency range XX=02; DC to 2 GHz XX=12 DC to 12 GHz XX=18 DC to 18 GHz Connectors YY & ZZ: 7mm = 90 N male = 51 N female = 61 TNC male= 31 TNC female = 41 SMA male = 11 SMA female = 21	
B2 ff	DC - 18.0	Phase Adjuster Series LS-0018-9292 Frequency range DC to 18 GHz Connectors 3.50 mm female	
C2 ff	DC - 8.0	Stripline Phase Adjuster Series LS-G108-2121 LS-K108-2121 LS-L108-2121 LS-T108-2121	
C2 ff	DC - 8.0	Frequency range DC to 8 GHz Connectors SMA female	

Adjusting Phase.indd.2014

2. Phase Adjustable Adapters			
Page	Frequency Range (GHz)	Features	Outline
D2 ff	DC - 12.0 DC - 18.0 DC - 26.0	Phase Adjustable Adapter LS-01XX-1121 Connectors SMA male to SMA female LS-01XX-1111 Connectors SMA male to SMA male LS-01XX-2121 Connectors SMA female to SMA female LS-02XX-1121 Connectors SMA female to SMA male XX: Frequency range, 12= DC to 12 GHz 18= DC to 18 GHz 21= DC to 26 GHz	
D8 ff	DC - 18.0	Phase Adjustable Adapter LS-0118-5161 Available Connectors: N	
D10 ff	DC - 18.0	Phase Adjustable Adapter LS-0118-3141 Main application: System Available Connectors: TNC	
D5 ff	DC - 26.0	Phase Adjustable Adapter LS-0070-XXYY Connectors: XX and YY: SMA male; SMA female	

Adjusting Phase.indd.2014

2. Phase Adjustable Adapters			
Frequency Range (GHz)	Features	Outline	Page
DC - 26.0	Phase Adjustable Adapter LS-0170-1121 Connectors: SMA male; SMA female		D5 ff
DC - 26.0	Phase Adjustable Adapter LS-0321-1121 Main application: System Connectors: SMA male to SMA female		D6 ff
DC - 26.0	Phase Adjustable Adapter LS-S008-1121 Main application: System/ Test Set Connectors: SMA male to SMA female		D7 ff
DC - 28.0	Phase Adjustable Adapter LS-0121-KFKM Connectors: 2.92mm male to 2.92mm female		D12 ff

Adjusting Phase.indd.2014

2. Phase Adjustable Adapters			
Page	Frequency Range (GHz)	Features	Outline
D14 ff	DC - 40.0	Phase Adjustable Adapter LS-0140-KFKM Connectors: 2.92mm male to 2.92mm female LS-0140-KFKF Connectors: 2.92mm female to 2.92mm female LS-0140-KMKM Connectors: 2.92mm male to 2.92mm male	
D16 ff	DC - 40.0	Phase Adjustable Adapter LS-0040-KFKM Main application: System/ Test Set Connectors: 2.92mm male to 2.92mm female	
D18 ff	DC - 50.0	Phase Adjustable Adapter LS-0150-HFHM Connectors: 2.4mm male to 2.4mm female LS-0150-HFHF Connectors: 2.4mm female to 2.4mm female LS-0150-HMHM Connectors: 2.4mm male to 2.4mm male	

Adjusting Phase.indd.2014

2. Phase Adjustable Adapters			
Frequency Range (GHz)	Features	Outline	Page
DC - 50.0	Phase Adjustable Adapter LS-0050-HFHM Connectors: 2.4 mm male / female LS-0050-HFVM Connectors: 2.4mm female, 1.85mm male		D20 ff
DC - 63.0	Phase Adjustable Adapter LS-0165-VFVM LS-P165-VFVM Connectors: 1.85mm male to 1.85mm female LS-0165-VFVF LS-P165-VFVF Connectors: 1.85mm female to 1.85mm female LS-0165-VMVM LS-P165-VMVM Connectors: 1.85mm male to 1.85mm female		D24 ff
DC - 63.0	Phase Adjustable Adapter LS-0065-VFVM Connectors: 1.85 mm male / female		D26 ff

Adjusting Phase.indd.2014

3. Phase Adjustable Connectors			
Page	Frequency Range (GHz)	Features	Outline
H2 ff	DC - 18.0	Phase Adjustable Cable Connector LS-0085-S001 Connector: SMA female	
H6 ff	DC - 18.0	Phase Adjustable Cable Connector 1102-65LS-04 Connector: SMP female	
H3 ff	DC - 26.0	Phase Adjustable Cable Connectors LS-0200-02 Connector: SMA female	
H2 ff	DC - 26.0	Phase Adjustable Cable Connectors for Semi-Rigid-Cable P/N LS-0085-02 P/N LS-0141-02 Connector: SMA male	
H2 ff	DC - 26.0	Phase Adjustable Cable Connectors with venting holes LS-V141-02 Connector: SMA male	

Adjusting Phase.indd.2014

3. Phase Adjustable Connectors			
Frequency Range (GHz)	Features	Outline	Page
DC - 18.0	Phase Adjustable Self Locking Cable Connectors of Type SMA straight for Phase Adjustment: 100° @ 18 GHz		H14 ff
DC - 18.0	Phase Adjustable Self Locking Cable Connectors of Type TNC straight Phase Adjustment: 100° @ 18 GHz		H14 ff
DC - 18.0	Phase Adjustable Self Locking Cable Connectors of Type TNC right angle Phase adjustments available: 100° max.		H16 ff
DC - 18.0	Phase Adjustable Self Locking Cable Connectors of Type TNC right angle Phase adjustments available: 240° max.		H16 ff
DC - 18.0	Phase Adjustable Self Locking Cable Connectors of Type TNC right angle Phase adjustments available: 280° max.		H16 ff

3. Phase Adjustable Connectors			
Page	Frequency Range (GHz)	Features	Outline
H14 ff	DC - 18.0	Phase Adjustable Self Locking Cable Connectors of Type SMA straight for Phase Adjustment: 280° @ 18 GHz	
H14 ff	DC - 18.0	Phase Adjustable Self Locking Cable Connectors of Type SMA right angle for Phase Adjustment: 100° @ 18 GHz	
H14 ff	DC - 18.0	Phase Adjustable Self Locking Cable Connectors of Type BMA female straight for Phase Adjustment: 100° @ 18 GHz	

You do not find in our catalog what you require? You need something special, designed to your application? Please talk to us.

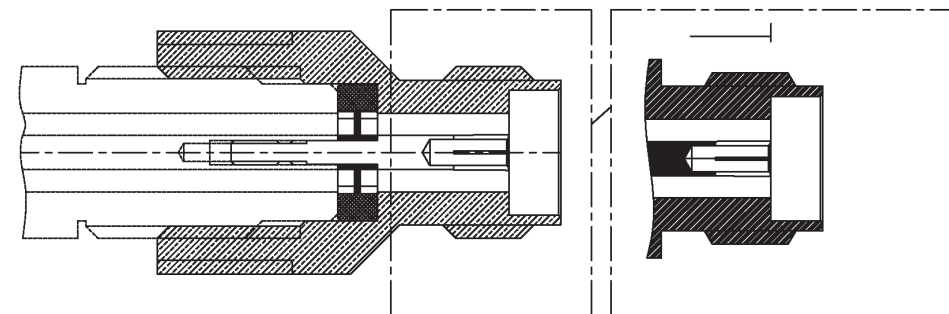

We have an engineering team, ready to design the product exactly to your needs.



Trombone Phase Adjuster

LS-0103-6161

Phaseshift: 180° at 1.0 GHz

Connectors: N

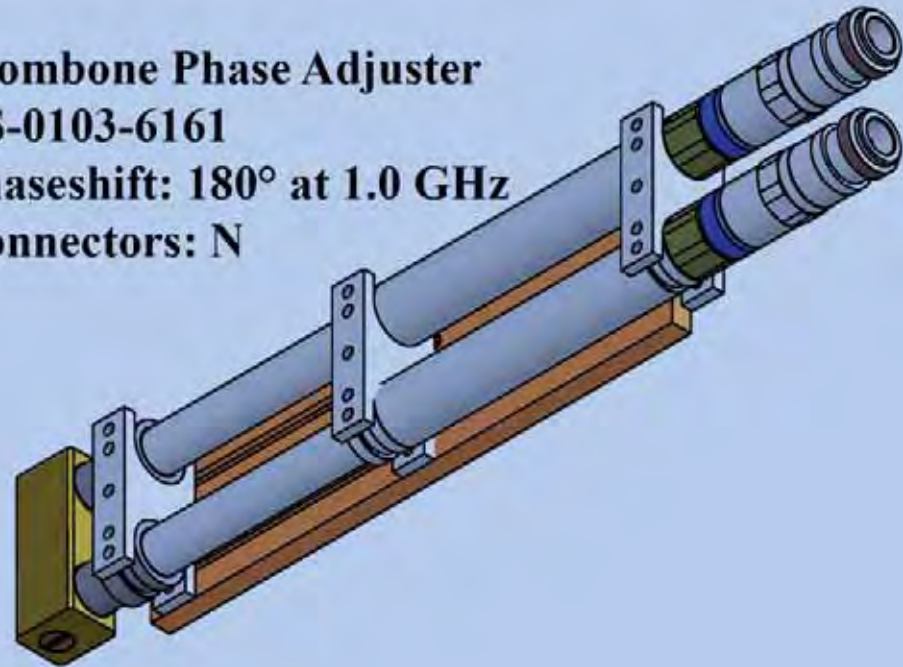

Trombone Phase Adjuster

LS-S203-6161

Phaseshift: 360° at 1.0 GHz

Connectors: N

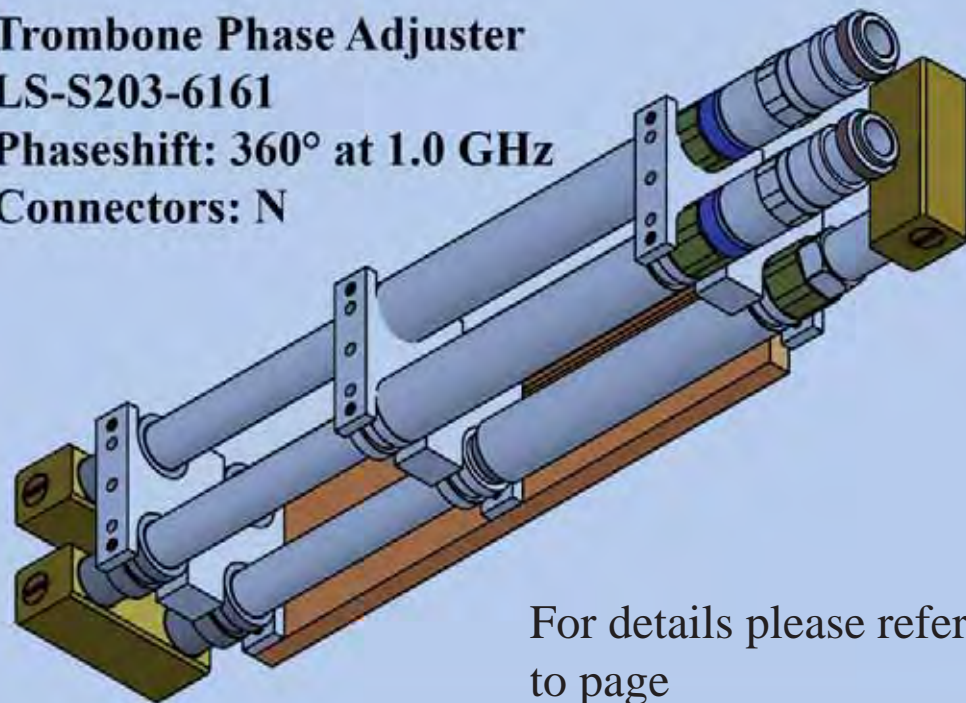

For details please refer to page

Adjusting Phase.indd.2014

Phase Adjusters

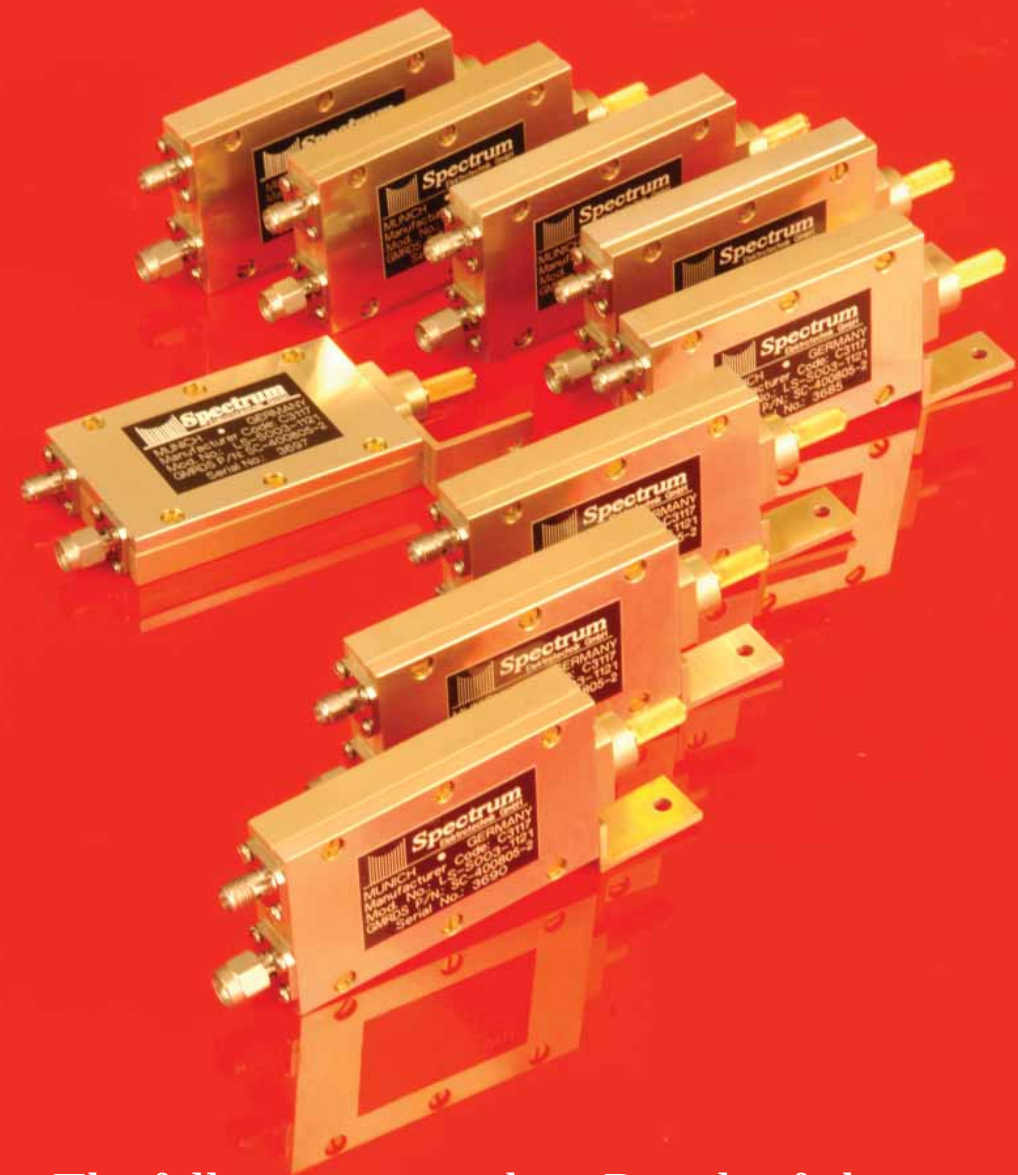

The following pages show Details of the
Phase Adjusters
in Flat Pack Housings

Adjusting Phase.indd.2014

- Application: System Use:**
"Set the electrical length and axial locking."
- Precision Phase Adjusters, DC to 2.0, 12.0 and 18.0 GHz.
 - Small housing, flat pack configuration.
 - Housing Finish: Iridited. On special request, painting can be supplied.
 - Four mounting locations are provided.
 - Impedance of 50 Ohms is maintained over the full adjustment range.
 - Positive resettable locking mechanism.
 - Smooth continuous phase adjustment.
 - Internal Trombone Line, no external physical length change.
 - Rugged construction: housing is made from aluminum, connector outer conductors from stainless steel.
 - Bead captivated center contacts.
 - Spring fingers and center contacts are made from beryllium copper, heat treated and gold plated per ASTM-B488, Type III, Code C

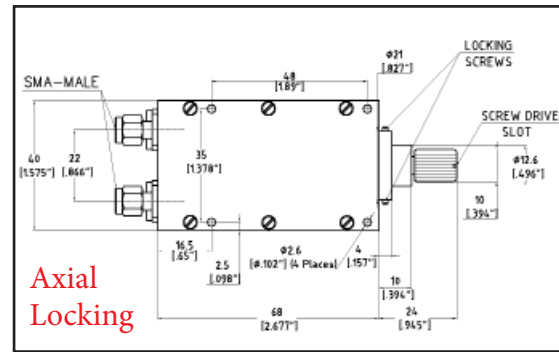

- Different connector configurations available, such as 7mm, SMA, N, and TNC. For other connector configurations, please consult the factory.
- Operating temperature range: -54°C to +115°C.

Part Number	Frequency	VSWR max.	R.F. Insertion Loss	Phase Shift	Connectors	Outline Dimensions		
						Length	Width	Height
LS-0002-1111	DC to 2.0 GHz	1.15:1	0.3 dB max @ 2.0 GHz	85° min. @ 2.0 GHz	SMA-M / SMA-M	68 mm 2.677"	40 mm 1.575"	12.7 mm .500"
LS-0002-1121					SMA-M / SMA-F			
LS-0002-2121					SMA-F / SMA-F			
LS-0002-5151		1.20:1	0.3 dB max @ 2.0 GHz	85° min. @ 2.0 GHz	N-M / N-M	68 mm 2.677"	42 mm 1.654"	22 mm .866"
LS-0002-5161					N-M / N-F			
LS-0002-6161					N-F / N-F			
LS-0002-3131					TNC-M / TNC-M			
LS-0002-3141	TNC-M / TNC-F							
LS-0002-4141	TNC-F / TNC-F							
LS-0012-1111	DC to 12.0 GHz	1.25:1	0.8 dB max @ 12.0 GHz	520° min. @ 12.0 GHz	SMA-M / SMA-M	68 mm 2.677"	40 mm 1.575"	12.7 mm .500"
LS-0012-1121					SMA-M / SMA-F			
LS-0012-2121					SMA-F / SMA-F			
LS-0012-5151		1.30:1	0.8 dB max @ 12.0 GHz	520° min. @ 12.0 GHz	N-M / N-M	68 mm 2.677"	42 mm 1.654"	22 mm .866"
LS-0012-5161					N-M / N-F			
LS-0012-6161					N-F / N-F			
LS-0012-3131					TNC-M / TNC-M			
LS-0012-3141	TNC-M / TNC-F							
LS-0012-4141	TNC-F / TNC-F							
LS-0018-1111	DC to 18.0 GHz	1.50:1	1.0 dB max @ 18.0 GHz	770° min. @ 18.0 GHz	SMA-M / SMA-M	68 mm 2.677"	40 mm 1.575"	12.7 mm .500"
LS-0018-1121					SMA-M / SMA-F			
LS-0018-2121					SMA-F / SMA-F			
LS-0018-9090					7 mm / 7 mm			
LS-0018-5151		1.50:1	1.0 dB max @ 18.0 GHz	770° min. @ 18.0 GHz	N-M / N-M	68 mm 2.677"	42 mm 1.654"	22 mm .866"
LS-0018-5161					N-M / N-F			
LS-0018-6161					N-F / N-F			
LS-0018-3131					TNC-M / TNC-M			
LS-0018-3141					TNC-M / TNC-F			
LS-0018-4141					TNC-F / TNC-F			
LS-0018-9191					3.5mm male/male			
LS-0018-9192					3.5mm male/female			
LS-0018-9292					3.5mm female/female			

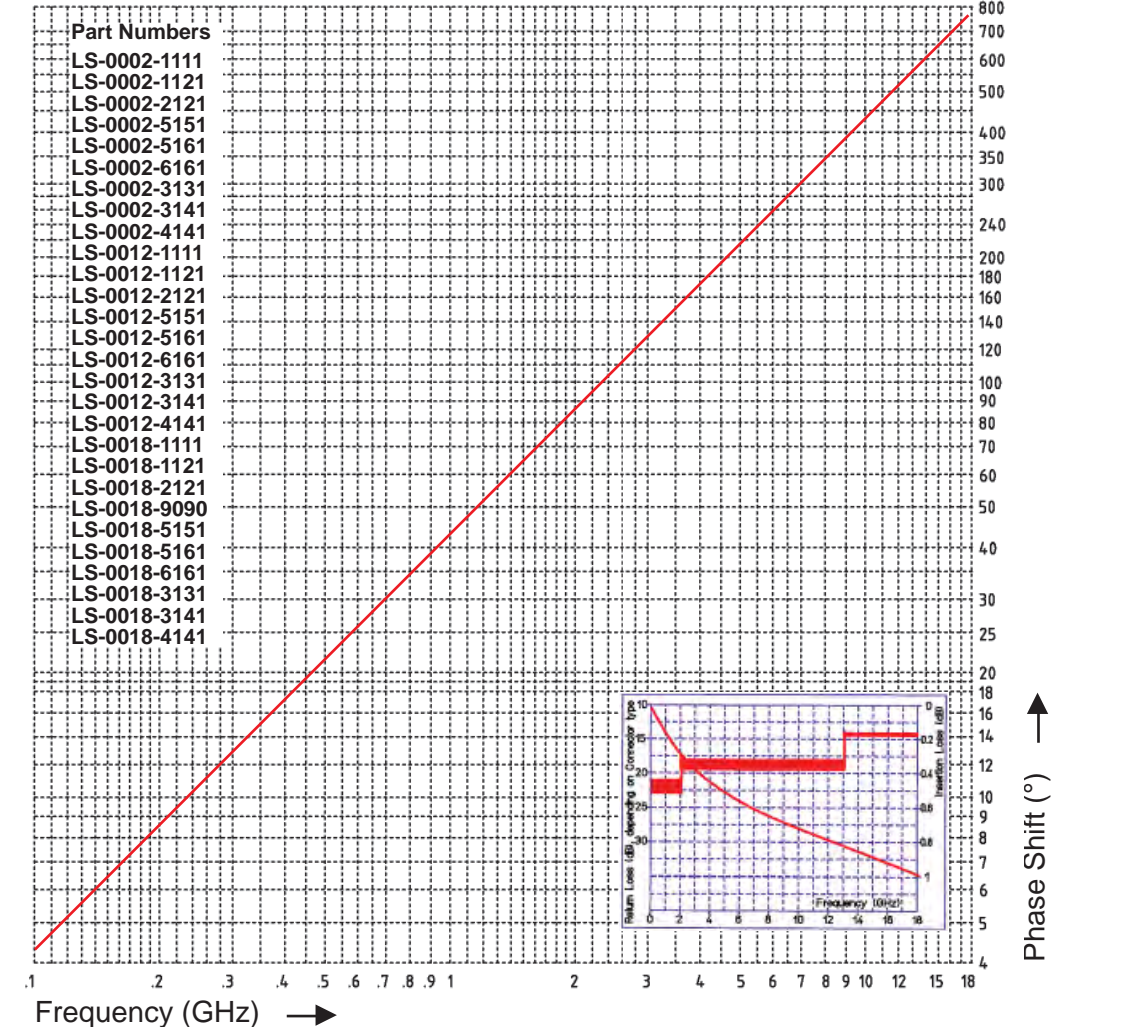

Part Number	LS-0002 - xxxx	LS-0012 - xxxx	LS-0018 - xxxx
	xxxx: connector configuration, for details please refer to the table on the left		
Frequency Range (GHz)	DC - 2.0	DC - 12.0	DC - 18.0
Min. Phase Shift (°)	85	520	770
Nominal Phase Shift Deg. / GHz / Shaft Turn	1.15	1.15	1.15
Max. number of Turns	37	37	37
Time Delay (psec)	min.	393	406
	max.	516	530

- Application: System Use:

"Set the electrical length and in line locking"

- Precision Phase Adjusters, DC to 2.0, 12.0 and 18.0 GHz.
- Small housing, flat pack configuration.
- Housing Finish: Iridited. On special request, painting can be supplied.
- Four mounting locations are provided.
- Impedance of 50 Ohms is maintained over the full adjustment range.
- Positive resettable locking mechanism.
- Smooth continuous phase adjustment.
- Internal Trombone Line, no external physical length change.
- Rugged construction: housing is made from aluminum, connector outer conductors from stainless steel.
- Bead captivated center contacts.
- Spring fingers and center contacts are made from beryllium copper, heat treated and gold plated per ASTM-B488, Type III, Code C

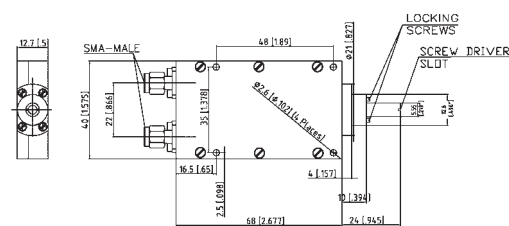

In line Locking

- Different connector configurations available, such as 7mm, SMA, N, and TNC. For other connector configurations, please consult the factory.
- Operating temperature range: -54°C to +115°C.

Part Number	Frequency	VSWR max.	R.F. Insertion Loss	Phase Shift	Connectors	Outline Dimensions		
						Length	Width	Height
LS-IL02-1111	DC to 2.0 GHz	1.15:1	0.3 dB max @ 2.0 GHz	85° min. @ 2.0 GHz	SMA-M / SMA-M	68 mm 2.677"	40 mm 1.575"	12.7 mm .500"
LS-IL02-1121					SMA-M / SMA-F			
LS-IL02-2121					SMA-F / SMA-F			
LS-IL02-5151	DC to 2.0 GHz	1.20:1	0.3 dB max @ 2.0 GHz	85° min. @ 2.0 GHz	N-M / N-M	68 mm 2.677"	42 mm 1.654"	22 mm .866"
LS-IL02-5161					N-M / N-F			
LS-IL02-6161					N-F / N-F			
LS-IL02-3131					TNC-M / TNC-M			
LS-IL02-3141					TNC-M / TNC-F			
LS-IL02-4141					TNC-F / TNC-F			
LS-IL12-1111	DC to 12.0 GHz	1.25:1	0.8 dB max @ 12.0GHz	520° min. @ 12.0GHz	SMA-M / SMA-M	68 mm 2.677"	40 mm 1.575"	12.7 mm .500"
LS-IL12-1121					SMA-M / SMA-F			
LS-IL12-2121					SMA-F / SMA-F			
LS-IL12-5151	DC to 12.0 GHz	1.30:1	0.8 dB max @ 12.0GHz	520° min. @ 12.0GHz	N-M / N-M	68 mm 2.677"	42 mm 1.654"	22 mm .866"
LS-IL12-5161					N-M / N-F			
LS-IL12-6161					N-F / N-F			
LS-IL12-3131					TNC-M / TNC-M			
LS-IL12-3141					TNC-M / TNC-F			
LS-IL12-4141					TNC-F / TNC-F			
LS-IL18-1111	DC to 18.0 GHz	1.50:1	1.0 dB max @ 18.0GHz	770° min. @ 18.0GHz	SMA-M / SMA-M	68 mm 2.677"	40 mm 1.575"	12.7 mm .500"
LS-IL18-1121					SMA-M / SMA-F			
LS-IL18-2121					SMA-F / SMA-F			
LS-IL18-9090	DC to 18.0 GHz	1.50:1	1.0 dB max @ 18.0GHz	770° min. @ 18.0GHz	7 mm / 7 mm	68 mm 2.677"	70 mm 2.756"	30 mm 1.181"
LS-IL18-5151					N-M / N-M			
LS-IL18-5161					N-M / N-F			
LS-IL18-6161					N-F / N-F			
LS-IL18-3131					TNC-M / TNC-M			
LS-IL18-3141					TNC-M / TNC-F			
LS-IL18-4141	TNC-F / TNC-F							

Adjusting Phase.indd.2014

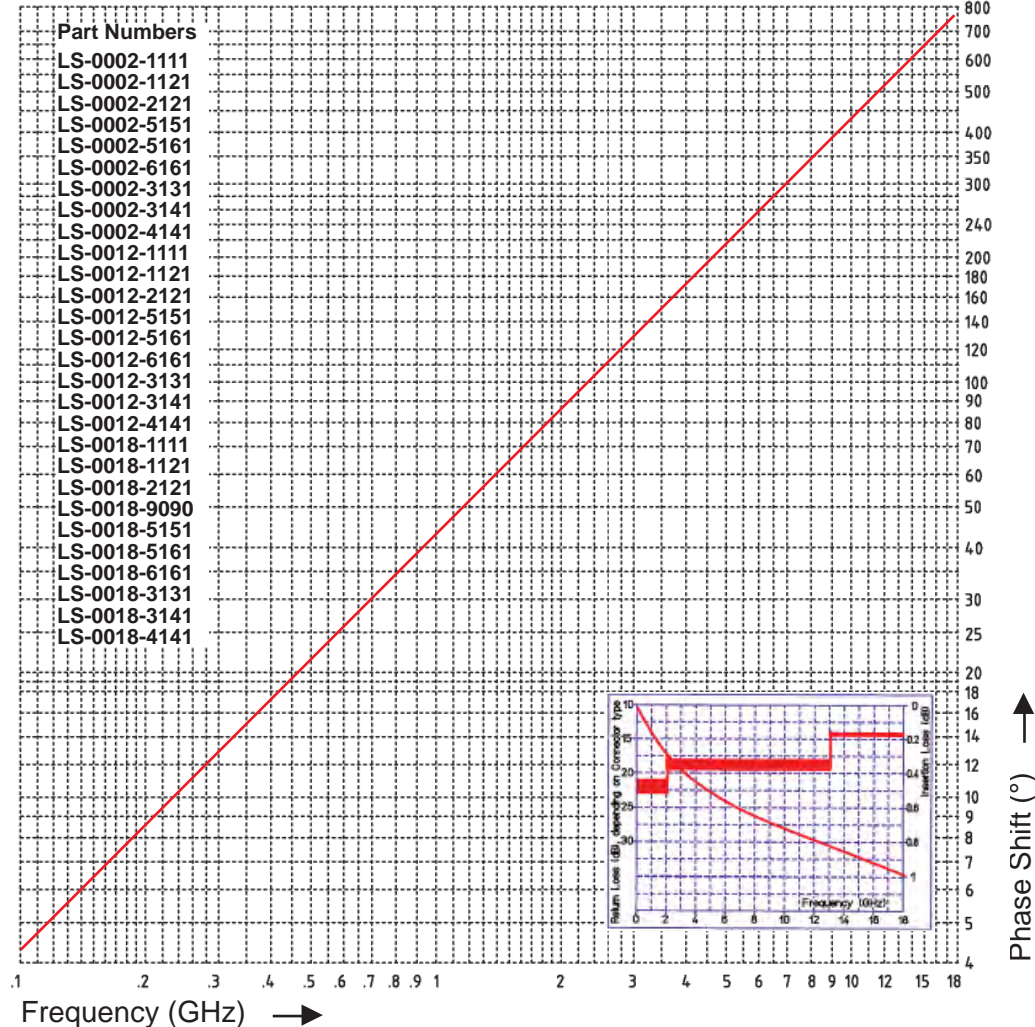

Part Number	LS-0002 - xxxx	LS-0012 - xxxx	LS-0018 - xxxx
	xxxx: connector configuration, for details please refer to the table on the left		
Frequency Range (GHz)	DC - 2.0	DC - 12.0	DC - 18.0
Min. Phase Shift (°)	85	520	770
Nominal Phase Shift Deg. / GHz / Shaft Turn	1.15	1.15	1.15
Max. number of Turns	37	37	37
Time Delay (psec)	min.	393	406
	max.	516	530

Application: Test Set & System Use:
"Adjust the electrical length many times"

- Ball Bearings adjustment.
- Precision Phase Adjusters, DC - 2.0, 12.0 and 18.0 GHz.
- Small housing, flat pack configuration.
- Housing Finish: Iridited. On special request, painting can be supplied.
- Four mounting locations are provided.
- Impedance of 50 Ohms is maintained over the full adjustment range.
- Positive resettable locking mechanism.
- Smooth continuous phase adjustment.
- Internal Trombone Line, no external physical length change.
- Rugged construction: housing is made from aluminum, connector outer conductors from stainless steel
- Bead captivated center contacts.
- Spring fingers and center contacts are made from beryllium copper, heat treated and gold plated per ASTM-B488, Type III, Code C

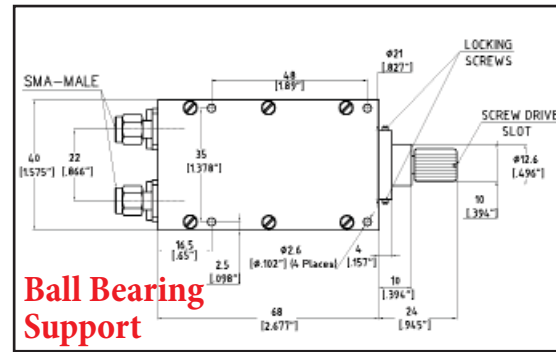

Ball Bearing Support

- Different connector configurations available, such as 7mm, SMA, N, and TNC. For other connector configurations, please consult the factory.
- Operating temperature range: -54°C to +115°C.

Part Number	Frequency	VSWR max.	R.F Insertion Loss	Phase Shift	Connectors	Outline Dimensions		
						Length	Width	Height
LS-B002-1111	DC to 2.0 GHz	1.15:1	0.3 dB max @ 2.0 GHz	85° min. @ 2.0 GHz	SMA-M / SMA-M	68 mm 2.677"	40 mm 1.575"	12.7 mm .500"
LS-B002-1121					SMA-M / SMA-F			
LS-B002-2121					SMA-F / SMA-F			
LS-B002-5151	DC to 2.0 GHz	1.20:1	0.3 dB max @ 2.0 GHz	85° min. @ 2.0 GHz	N-M / N-M	68 mm 2.677"	42 mm 1.654"	22.0 mm .866"
LS-B002-5161					N-M / N-F			
LS-B002-6161					N-F / N-F			
LS-B002-3131					TNC-M / TNC-M			
LS-B002-3141					TNC-M / TNC-F			
LS-B002-4141					TNC-F / TNC-F			
LS-B012-1111	DC to 12.0 GHz	1.25:1	0.8 dB max @ 12.0GHz	520° min. @ 12.0GHz	SMA-M / SMA-M	68 mm 2.677"	40 mm 1.575"	12.7 mm .500"
LS-B012-1121					SMA-M / SMA-F			
LS-B012-2121					SMA-F / SMA-F			
LS-B012-5151	DC to 12.0 GHz	1.30:1	0.8 dB max @ 12.0GHz	520° min. @ 12.0GHz	N-M / N-M	68 mm 2.677"	42 mm 1.654"	22.0 mm .866"
LS-B012-5161					N-M / N-F			
LS-B012-6161					N-F / N-F			
LS-B012-3131					TNC-M / TNC-M			
LS-B012-3141					TNC-M / TNC-F			
LS-B012-4141					TNC-F / TNC-F			
LS-B018-1111	DC to 18.0 GHz	1.50:1	1.0 dB max @ 18.0GHz	770° min. @ 18.0GHz	SMA-M / SMA-M	68 mm 2.677"	40 mm 1.575"	12.7 mm .500"
LS-B018-1121					SMA-M / SMA-F			
LS-B018-2121					SMA-F / SMA-F			
LS-B018-9090	DC to 18.0 GHz	1.50:1	1.0 dB max @ 18.0GHz	770° min. @ 18.0GHz	7 mm / 7 mm	68 mm 2.677"	70 mm 2.756"	30 mm 1.181"
LS-B018-5151					N-M / N-M			
LS-B018-5161					N-M / N-F			
LS-B018-6161					N-F / N-F			
LS-B018-3131					TNC-M / TNC-M			
LS-B018-3141					TNC-M / TNC-F			
LS-B018-4141	TNC-F / TNC-F							

Adjusting Phase.indd.2014

Part Numbers

- LS-B002-1111
- LS-B002-1121
- LS-B002-2121
- LS-B002-5151
- LS-B002-5161
- LS-B002-6161
- LS-B002-3131
- LS-B002-3141
- LS-B002-4141
- LS-B012-1111
- LS-B012-1121
- LS-B012-2121
- LS-B012-5151
- LS-B012-5161
- LS-B012-6161
- LS-B012-3131
- LS-B012-3141
- LS-B012-4141
- LS-B018-1111
- LS-B018-1121
- LS-B018-2121
- LS-B018-9090
- LS-B018-5151
- LS-B018-5161
- LS-B018-6161
- LS-B018-3131
- LS-B018-3141
- LS-B018-4141

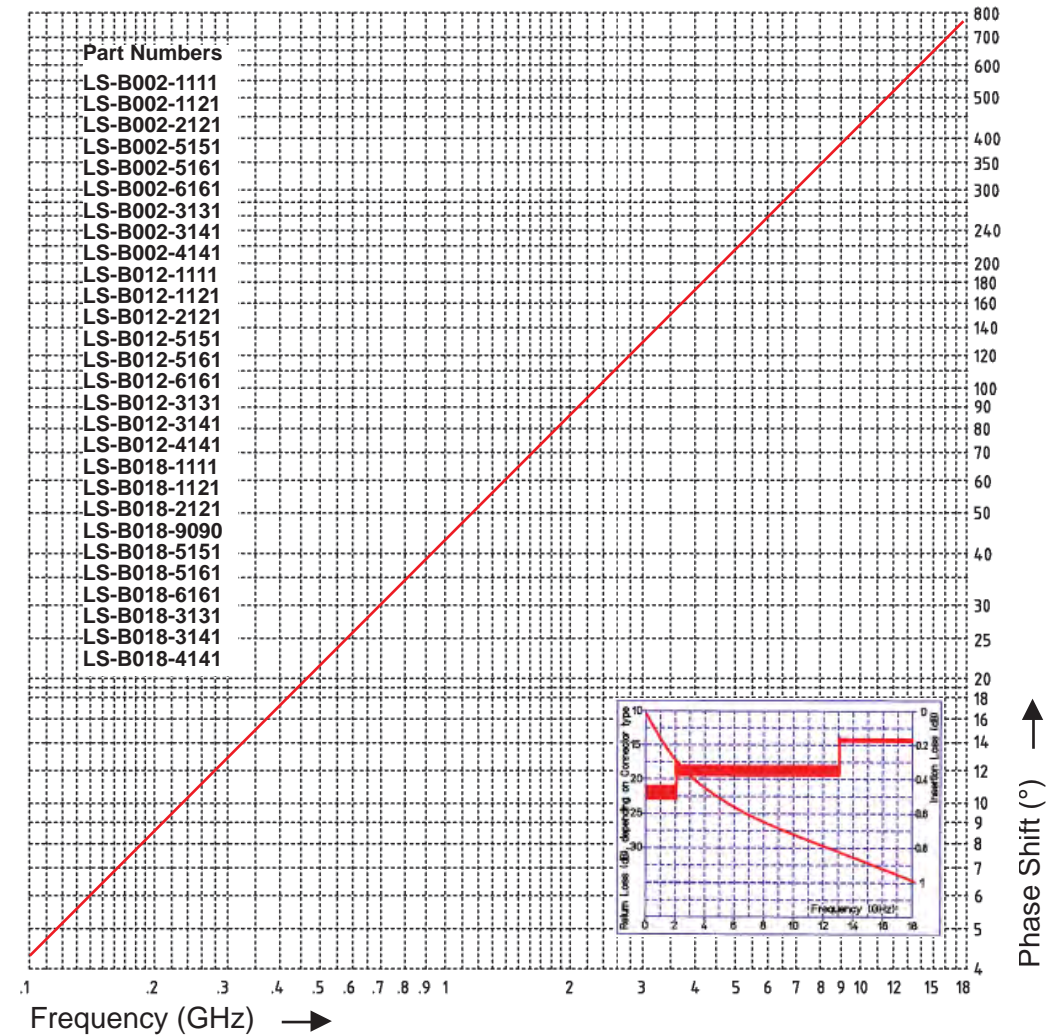

Adjusting Phase.indd.2014

Part Number	LS-B002 - xxxx	LS-B012 - xxxx	LS-B018 - xxxx
	xxxx: connector configuration, for details please refer to the table on the left		
Frequency Range (GHz)	DC - 2.0	DC - 12.0	DC - 18.0
Min. Phase Shift (°)	85	520	770
Nominal Phase Shift Deg. / GHz / Shaft Turn	1.15	1.15	1.15
Max. number of Turns	37	37	37
Time Delay (psec)	min.	393	406
	max.	516	530

Application: Test Set
 "Set the electrical length by micrometer adjustment".

- Precision Phase Adjusters, DC to 2.0, 12.0 and 18.0 GHz.
- Small housing, flat pack configuration.
- Housing Finish: Iridited. On special request, painting can be supplied.
- Four mounting locations are provided.
- Impedance of 50 Ohms is maintained over the full adjustment range.
- Smooth continuous phase adjustment.
- Internal Trombone Line, no external physical length change.
- Rugged construction: housing is made from aluminum, connector outer conductors from stainless steel.
- Bead captivated center contacts
- Spring fingers and center contacts are made from beryllium copper, heat treated and gold plated per ASTM-B488, Type III, Code C

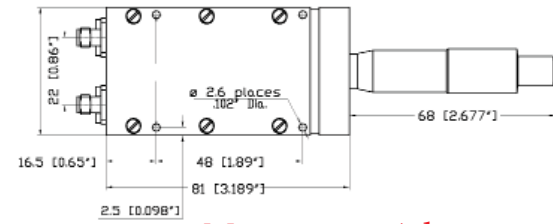

Micrometer Adjustment

- Different connector configurations available, such as 7mm, SMA, N, and TNC. For other connector configurations, please consult the factory.
- Operating temperature range: -54°C to +115°C.

Part Number	Frequency	VSWR max.	R.F Insertion Loss	Phase Shift	Connectors	Outline Dimensions		
						Length	Width	Height
LS-M002-1111	DC to 2.0 GHz	1.15:1	0.3 dB max @ 2.0 GHz	85° min. @ 2.0 GHz	SMA-M / SMA-M	81 mm 3.189"	40 mm 1.575"	20 mm .787"
LS-M002-1121					SMA-M / SMA-F			
LS-M002-2121					SMA-F / SMA-F			
LS-M002-5151		1.20:1	0.3 dB max @ 2.0 GHz	85° min. @ 2.0 GHz	N-M / N-M	81 mm 3.189"	42 mm 1.654"	22 mm .866"
LS-M002-5161					N-M / N-F			
LS-M002-6161					N-F / N-F			
LS-M002-3131					TNC-M / TNC-M			
LS-M002-3141					TNC-M / TNC-F			
LS-M002-4141					TNC-F / TNC-F			
LS-M012-1111	DC to 12.0 GHz	1.25:1	0.8 dB max @ 12.0GHz	520° min. @ 12.0GHz	SMA-M / SMA-M	81 mm 3.189"	40 mm 1.575"	20 mm .787"
LS-M012-1121					SMA-M / SMA-F			
LS-M012-2121					SMA-F / SMA-F			
LS-M012-5151		1.30:1	0.8 dB max @ 12.0GHz	520° min. @ 12.0GHz	N-M / N-M	81 mm 3.189"	42 mm 1.654"	22 mm .866"
LS-M012-5161					N-M / N-F			
LS-M012-6161					N-F / N-F			
LS-M012-3131					TNC-M / TNC-M			
LS-M012-3141					TNC-M / TNC-F			
LS-M012-4141					TNC-F / TNC-F			
LS-M018-1111	DC to 18.0 GHz	1.50:1	1.0 dB max @ 18.0GHz	770° min. @ 18.0GHz	SMA-M / SMA-M	81 mm 3.189"	40 mm 1.575"	20 mm .787"
LS-M018-1121					SMA-M / SMA-F			
LS-M018-2121					SMA-F / SMA-F			
LS-M018-9090		1.50:1	1.0 dB max @ 18.0GHz	770° min. @ 18.0GHz	7 mm / 7 mm	81 mm 3.189"	70 mm 2.756"	30 mm 1.181"
LS-M018-5151					N-M / N-M			
LS-M018-5161					N-M / N-F			
LS-M018-6161					N-F / N-F			
LS-M018-3131					TNC-M / TNC-M			
LS-M018-3141					TNC-M / TNC-F			
LS-M018-4141	TNC-F / TNC-F							

Adjusting Phase.indd.2014

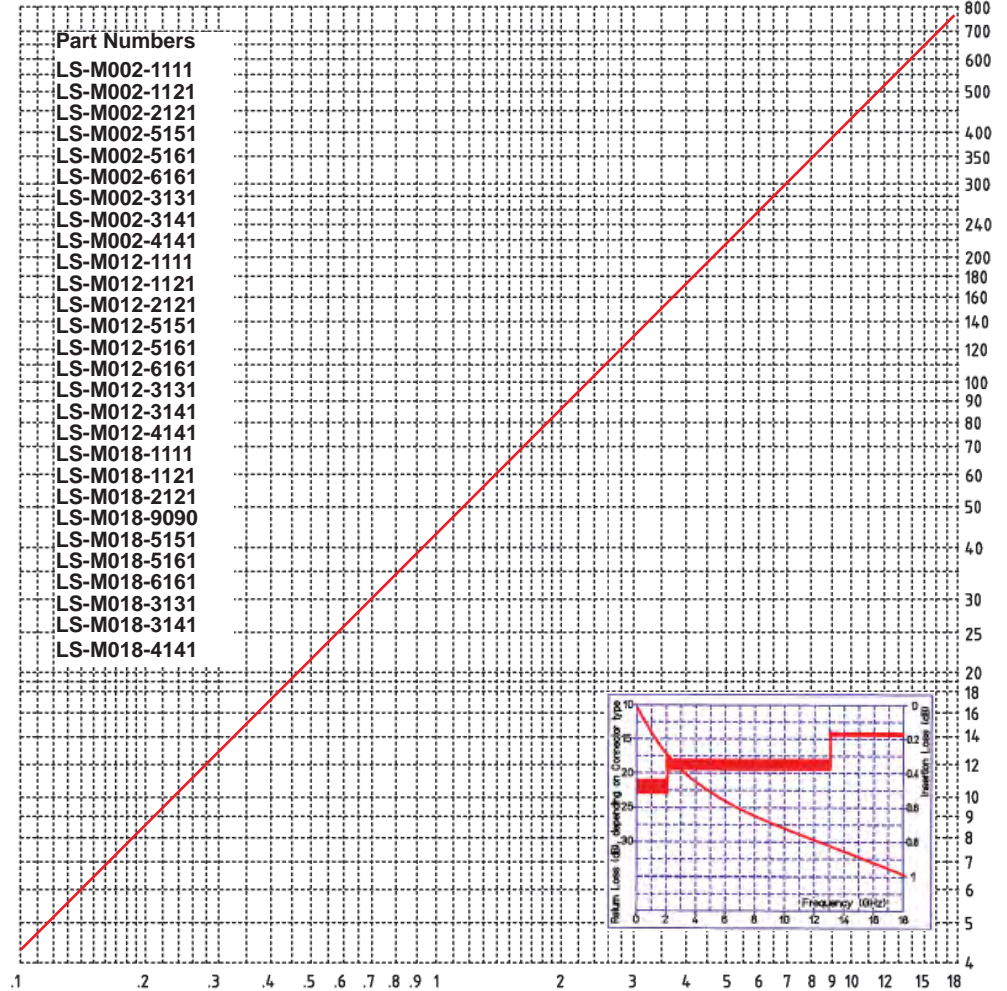

- Part Numbers**
- LS-M002-1111
 - LS-M002-1121
 - LS-M002-2121
 - LS-M002-5151
 - LS-M002-5161
 - LS-M002-6161
 - LS-M002-3131
 - LS-M002-3141
 - LS-M002-4141
 - LS-M012-1111
 - LS-M012-1121
 - LS-M012-2121
 - LS-M012-5151
 - LS-M012-5161
 - LS-M012-6161
 - LS-M012-3131
 - LS-M012-3141
 - LS-M012-4141
 - LS-M018-1111
 - LS-M018-1121
 - LS-M018-2121
 - LS-M018-9090
 - LS-M018-5151
 - LS-M018-5161
 - LS-M018-6161
 - LS-M018-3131
 - LS-M018-3141
 - LS-M018-4141

Part Number	LS-M002 - xxxx	LS-M012 - xxxx	LS-M018 - xxxx
	xxxx: connector configuration, for details please refer to the table on the left		
Frequency Range (GHz)	DC - 2.0	DC - 12.0	DC - 18.0
Min. Phase Shift (°)	85	520	770
Nominal Phase Shift Deg. / GHz / Shaft Turn	1.15	1.15	1.15
Max. number of Turns	37	37	37
Time Delay (psec)	min.	393	406
	max.	516	530

Adjusting Phase.indd.2014

Stripline Phase Adjustable Adapters

**Application: System Use: "Set the electrical length with no locking needed due to the design."**

- Precision Phase Adjusters, DC to 8.0 GHz.
- Small housing, flat pack configuration.
- Two mounting locations are provided. Other mounting positions are offered on request.
- Impedance of 50 Ohms is maintained over the full adjustment range.
- Smooth continuous phase adjustment.
- The electrical length change does not require an external physical length change.
- Rugged construction: housing is made from aluminum, connector outer conductors from stainless steel.
- Captivated connector center contacts.
- Operating temperature range: -40°C to +115°C.
- Differences of the designs to the right are: round vs. quadratic housing and 4-Hole flanged connector vs. 2-Hole flange.
- Different connector configurations may be offered on request. The Housing height may change.

The design shall be such that the outline dimensions in this catalog are met. In addition, the connectors shall meet the interface dimensions per MIL-PRF-39012

Materials:

ALUMINUM, AlMg4.5Mn per DIN 1725, AlMgSi0.5 per DIN 1725, AlMgSi1 per DIN 1725 (6061-T6 per QQ-A-225/8).
STEEL corrosion resistant 1.4305 per DIN 17440 (QQ-S-764, class 303 or ASTM-A-582-80).

BRASS, CuZn39Pb3 per DIN 17660 (QQ-B-626, half hard).

COPPER BERYLLIUM 33-25 CuBe2Pb H per DIN 17666 (QQ-C-530).

PTFE, Fluorocarbon per DIN 52900 (MIL-P-19468 and L-P403).

SILICONE RUBBER, per DIN 3771 (MIL-R-5847 and ZZ-R-765, Class II B,) Grade 50 - 75.

STRIPLINE per in-house specification

POLYETHERIMIDE per in-house specification

Surface Treatments:

Center Contacts shall be gold plated to a minimum thickness of .00005 inch (1.27 μm) in accordance with MIL-G-45204, Type II, Grade C.

Stainless steel connector housings shall be passivated per QQ-P-35.

Aluminum Housings shall have a Surtech finish, corrosion resistant according to MIL-DTL-5541F and MIL-DTL-81706B

Stripline Phase Adjustable Adapters

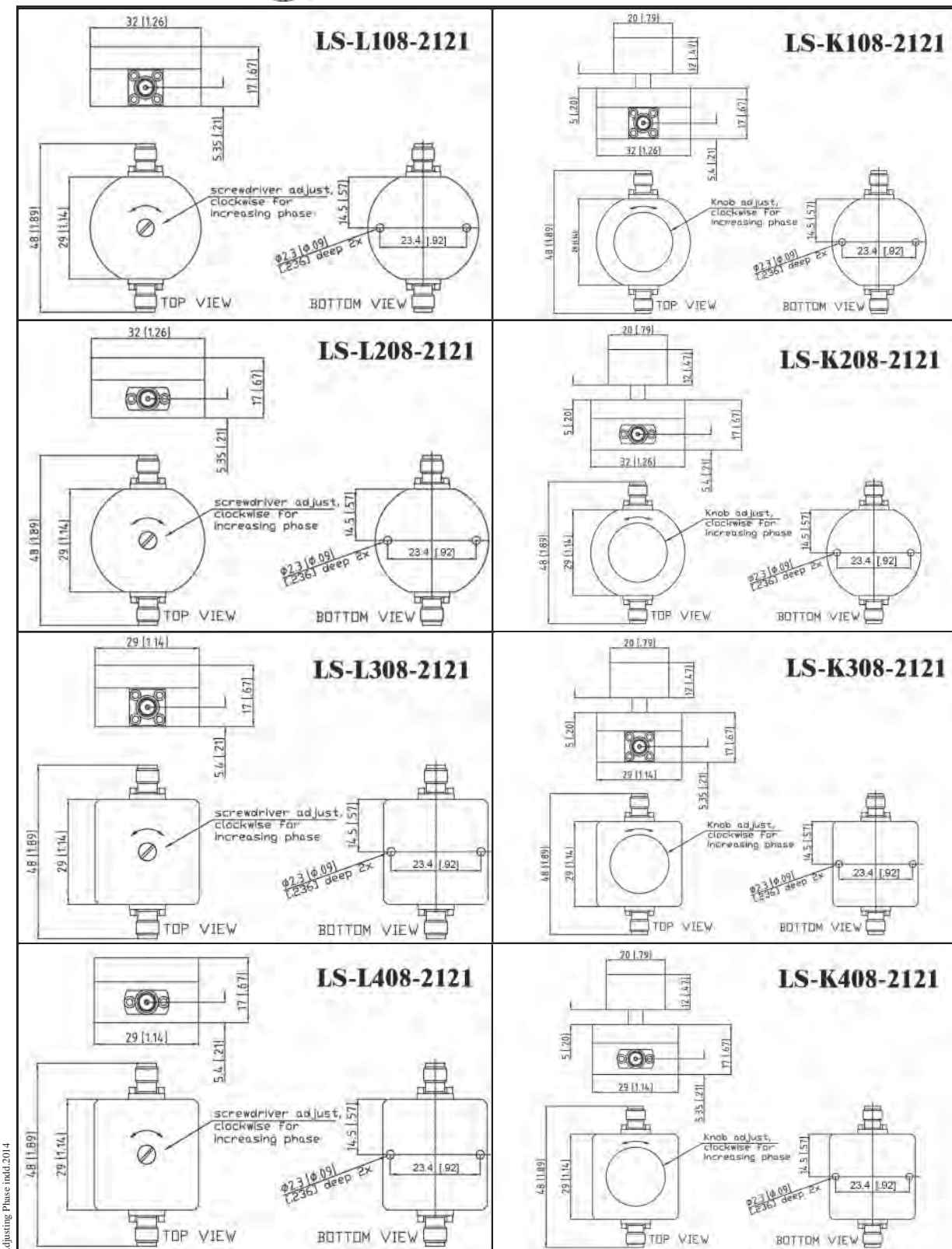



Adjusting Phase.indd.2014

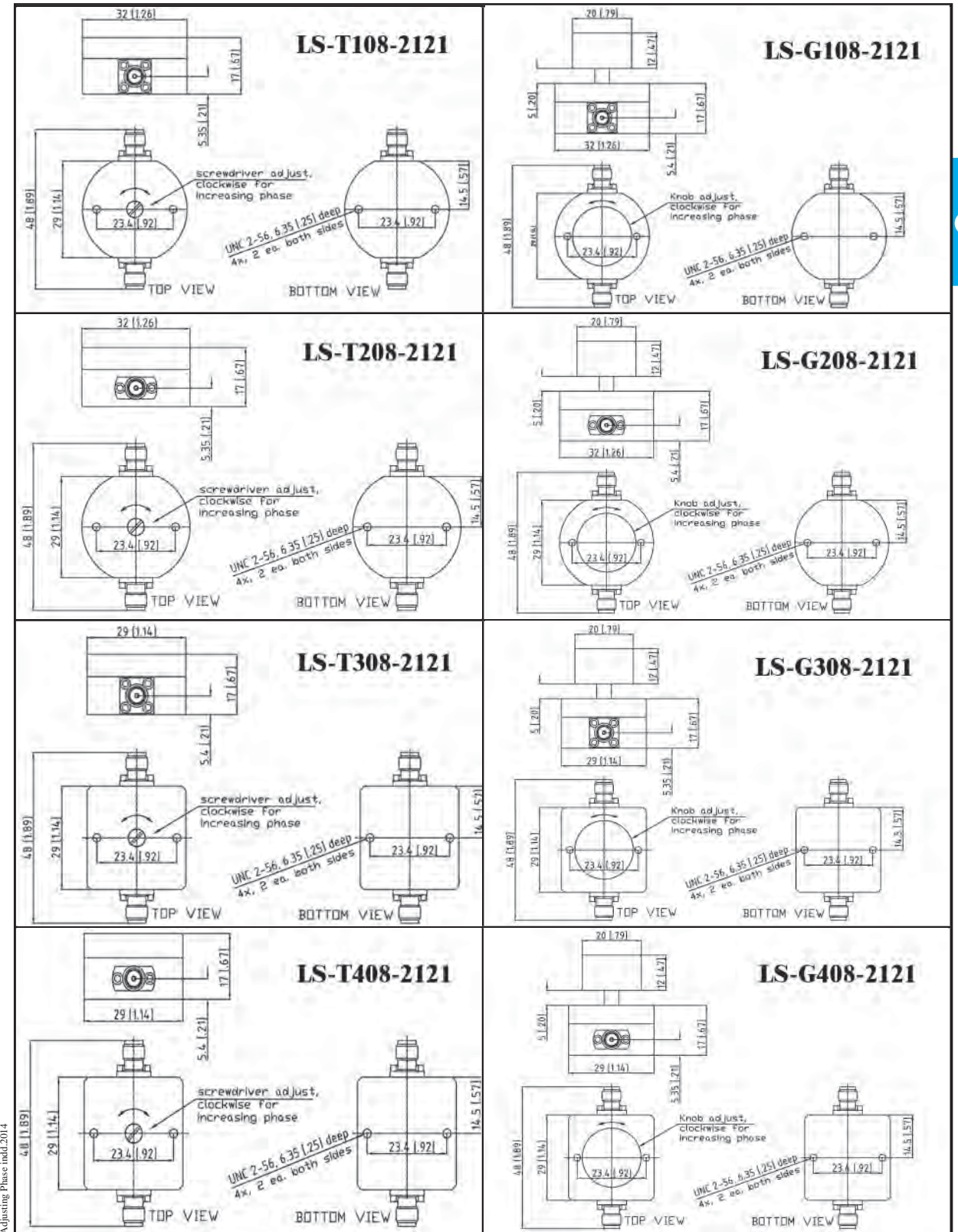

Adjusting Phase.indd.2014

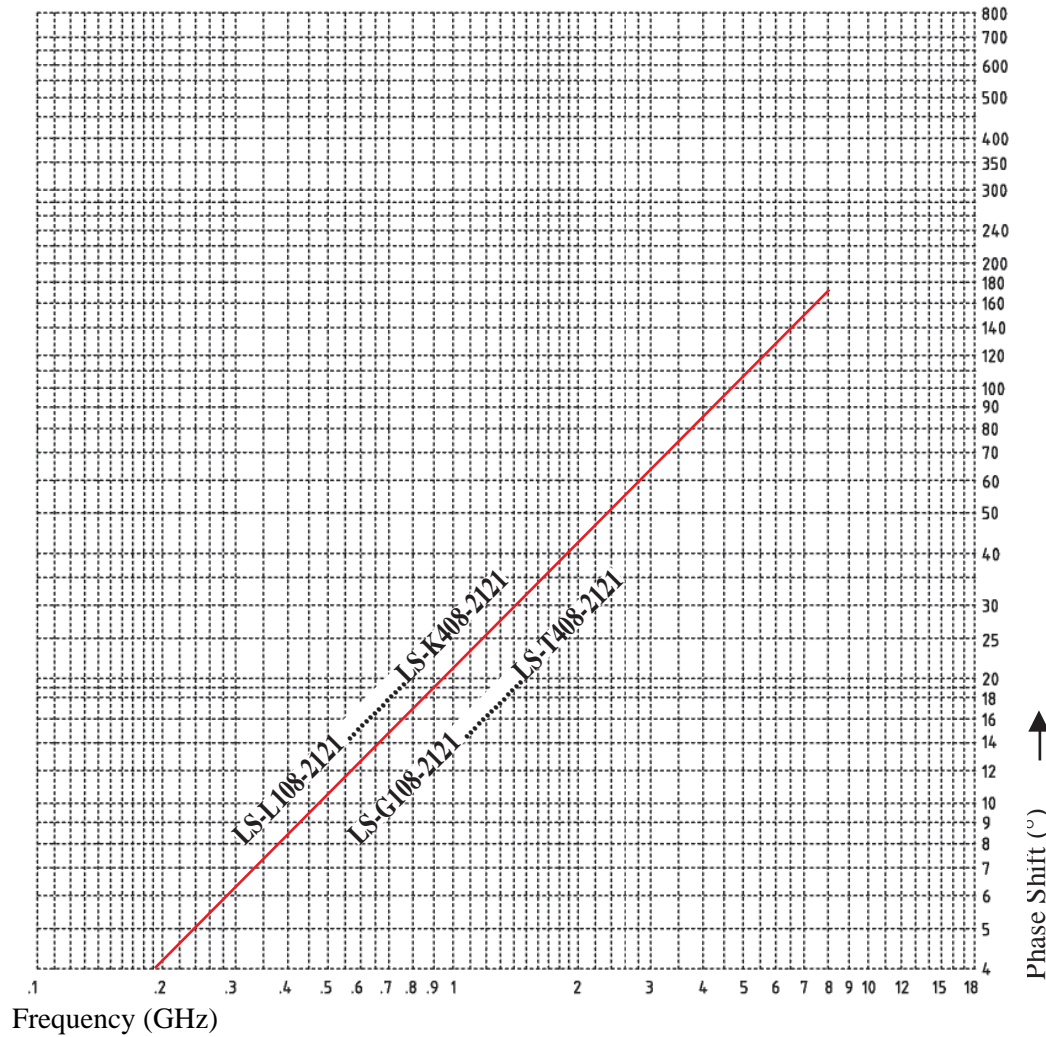

PartNumber	Connectors	Sex	Frequency Range (GHz)	VSWR max.	Insertion Los max. (dB)	Phase Shift min.	Turn Angle approx.	Insertion Phase typ. min.-max.°	Material Weight
LS-G108-2121	SMA	F-F	DC-8.0	1.30:1	0.8	22° @ 1 GHz 65° @ 3 GHz 130° @ 6 GHz 175° @ 8 GHz	55°	1 GHz:110 - 130 3 GHz:325 - 390 6 GHz:650 - 780 8 GHz: 865 - 1040	Aluminum iridite finish LS-L... 45g / 1.56oz LS-K... 50g / 1.76oz
LS-G208-2121									
LS-G308-2121									
LS-G408-2121									
LS-K108-2121									
LS-K208-2121									
LS-K308-2121									
LS-K408-2121									
LS-L108-2121									
LS-L208-2121									
LS-L308-2121									
LS-L408-2121									
LS-T108-2121									
LS-T208-2121									
LS-T308-2121									
LS-T408-2121									

Adjusting Phase.indd.2014

Phase Adjustable Adapters



DC - 12.0 GHz
 DC - 18.0 GHz
 DC - 26.0 GHz
 DC - 40.0 GHz
 DC - 50.0 GHz
 DC - 63.0 GHz

SMA Male to SMA Female		
Part Number	Frequency Range	Material
LS-0112-1121	DC - 12.0 GHz	Stainless Steel Body
LS-0118-1121	DC - 18.0 GHz	
LS-0121-1121	DC - 26.0 GHz	
LS-A112-1121	DC - 12.0 GHz	Aluminum Body
LS-A118-1121	DC - 18.0 GHz	
LS-A121-1121	DC - 26.0 GHz	

SMA Male to SMA Male		
Part Number	Frequency Range	Material
LS-0112-1111	DC - 12.0 GHz	Stainless Steel Body
LS-0118-1111	DC - 18.0 GHz	
LS-0121-1111	DC - 26.0 GHz	
LS-A112-1111	DC - 12.0 GHz	Aluminum Body
LS-A118-1111	DC - 18.0 GHz	
LS-A121-1111	DC - 26.0 GHz	

SMA Female to SMA Female		
Part Number	Frequency Range	Material
LS-0112-2121	DC - 12.0 GHz	Stainless Steel Body
LS-0118-2121	DC - 18.0 GHz	
LS-0121-2121	DC - 26.0 GHz	
LS-A112-2121	DC - 12.0 GHz	Aluminum Body
LS-A118-2121	DC - 18.0 GHz	
LS-A121-2121	DC - 26.0 GHz	

SMA Female to SMA Male		
Part Number	Frequency Range	Material
LS-0212-1121	DC - 12.0 GHz	Stainless Steel Body
LS-0218-1121	DC - 18.0 GHz	
LS-0221-1121	DC - 26.0 GHz	
LS-A212-1121	DC - 12.0 GHz	Aluminum Body
LS-A218-1121	DC - 18.0 GHz	
LS-A221-1121	DC - 26.0 GHz	

Adjusting Phase.indd.2014

- Precision phase adjustable adapters, DC to 12.0,18.0 and 26.0 GHz.
- Impedance of 50 Ohms is maintained over the full adjustment range.
- Positive resettable locking mechanism.
- Smooth continuous phase adjustment
- Physical length change of the unit equals the electrical length change.
- Rugged construction, housing and outer conductors are made from stainless steel.
- Light weight components are available, using aluminum for the housing, but for physical endurance connector outer shells are still supplied in stainless steel.
- Capitated center contacts.
- Spring fingers and center contacts are made from beryllium copper, heat treated and gold plated per ASTM-B-488; Type III, Code C
- SMA connector interface specification per MIL-STD-348A
- Four different connector configurations can be obtained, as shown in the drawings: SMAm - SMAf, SMAm - SMAm, SMAf - SMAf, SMAf - SMAm
- Operating temperature range: -54°C to +115°C, units with extended temperature range are available on request.
- Mounting Brackets are optional and are shown on the drawings on the next page.
- Diagram Phase Shift (°) vers. Frequency Range (GHz), please refer to page D4.

Table for Phase Adjustable Adapters, as shown on the left.

Part Number	Sex	Frequency Range	VSWR max.	Insertion Loss max.	Phase Shift min.	No. of Turns	Nom. Phase Shift Deg./GHz/Turn	Time Delay (psec.) min. max.	Material/Weight max.							
LS-0112-1111	M-M	DC-12.0 GHz	1.25:1	0.4 dB	230° at 12.0 GHz	16.5	1.2	238 293	Stainless Steel 70 g							
LS-0112-1121	M-F															
LS-0112-2121	F-F															
LS-0212-1121	F-M								DC-18.0 GHz	1.25:1	0.6 dB	350° at 18.0 GHz	16.5	1.2	238 293	Aluminum 47 g
LS-A112-1111	M-M															
LS-A112-1121	M-F															
LS-A112-2121	F-F	DC-26.0 GHz	1.30:1	0.8 dB	500° at 26.0 GHz	16.5	1.2	238 293	Stainless Steel 70 g							
LS-A212-1121	F-M															
LS-0121-1111	M-M															
LS-0121-1121	M-F															
LS-0121-2121	F-F															
LS-0221-1121	F-M															
LS-A121-1111	M-M	Aluminum 47 g														
LS-A121-1121	M-F															
LS-A121-2121	F-F															
LS-A218-1121	F-M															

Adjusting Phase.indd.2014

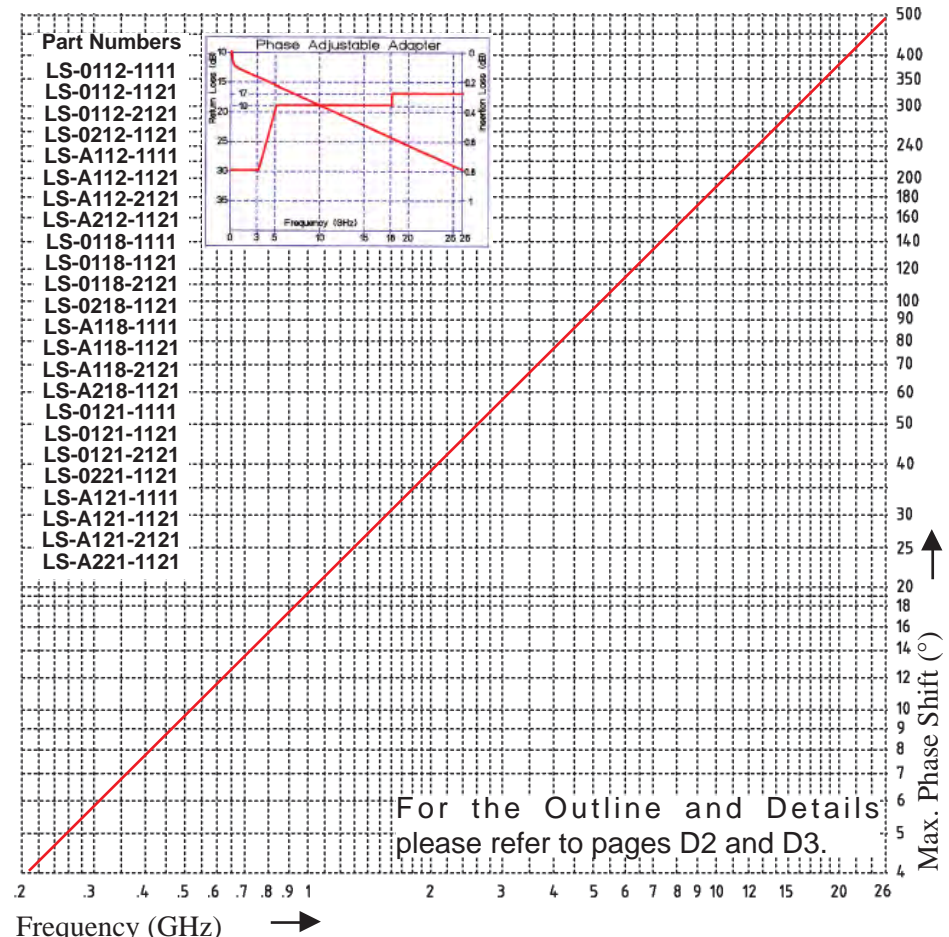

- Precision phase adjustable miniature adapters, DC to 26.0 GHz.
- Impedance of 50 Ohms is maintained over the full adjustment range.
- Positive resettable locking mechanism.
- Smooth continuous phase adjustment.
- Physical length change of the unit equals the electrical length change.
- Rugged construction, housing and outer conductors are made from stainless steel.
- Captivated center contacts.
- Spring fingers and center contacts are made from beryllium copper, heat treated and gold plated per ASTM-B-488; Type III, Code C
- SMA connector interface specification per MIL-STD-348A.
- Operating temperature range: -54°C to +115°C, units with extended temperature range are available on request.
- Physical length change per revolution of adjustment nut: ~ 0.30 mm
- Electrical length change per revolution of adjustment nut: ~ 0.30 mm
- Maximum change in physical length 4.06 +/- 0.25 mm of air

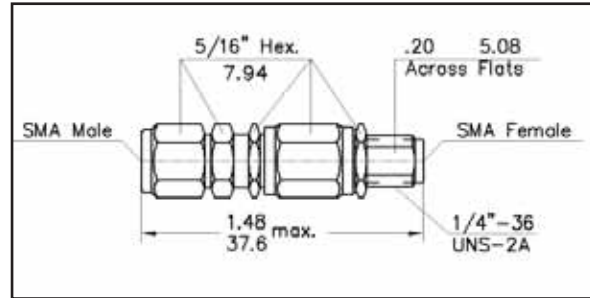

The difference between the adapters is:
 The **LS-0170-1121** can be taken apart completely after the max. position and is only available in SMAm/SMAf.
 The **LS-0070-XXYY** cannot be taken apart and is available in SMAm / SMAm; SMAm / SMAf; and SAMf / SMAf.

Part Number	Frequency Range	VSWR max.	Insertion Loss max.	Phase Shift min.	No. of Turns	Nom. Phase Shift Deg./GHz/Turn	Time Delay (psec.) min. max.	Weight max.
LS-0070-XXYY LS-0170-1121	DC-26.0 GHz	1.06+.009*f(GHz)	0.26 dB	127° at 26.0 GHz	13.5	0.36	109.2 122.8	9 g

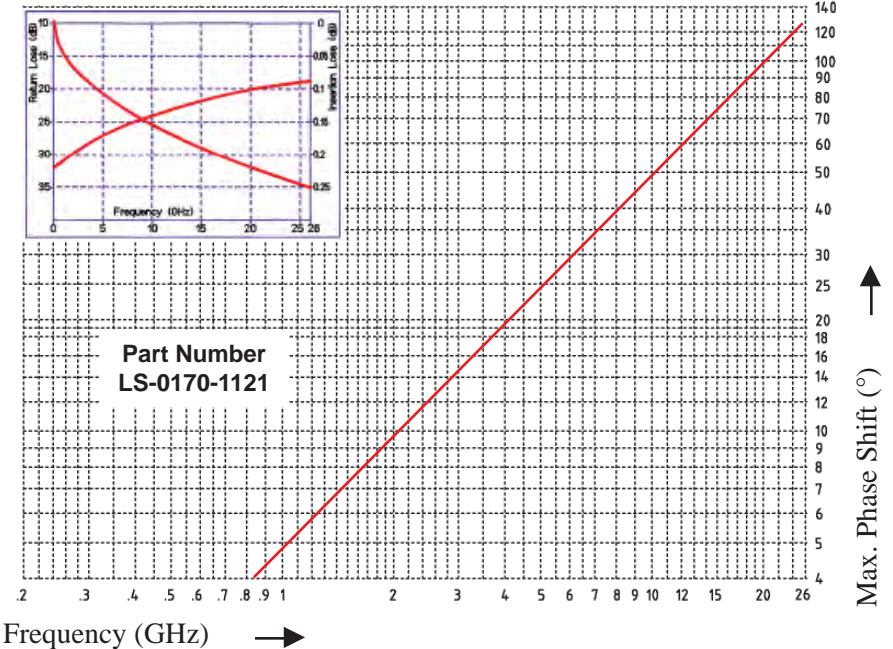

Two different Mounting Brackets are offered. They can easily be added to any Precision Phase Adjuster. Using these standard attachments makes it easy to mount the Phase Shifter in the system or to the test setup and ensures proper operation.

mounting at only one side

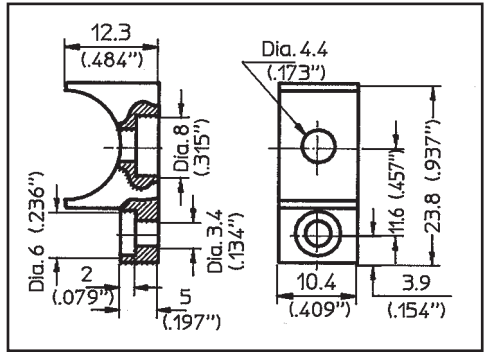

Bracket, Part No.: MB-0100-07
 Material: Aluminum iridited

mounting at both sides

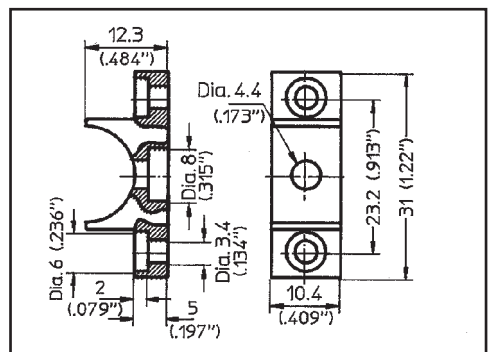

Bracket, Part No.: MB-0200-07
 Material: Aluminum iridited

Adjusting Phase.indd.2014

Adjusting Phase.indd.2014

Phase Adjustable Adapter DC to 26.0 GHz



- Precision phase adjustable adapters, DC to 26.0 GHz.
- Impedance of 50 Ohms is maintained over the full adjustment range.
- Positive resettable locking mechanism.
- Smooth continuous phase adjustment.
- Physical length change of the unit equals the electrical length change.
- Rugged construction, housing and outer conductors are made from stainless steel.

- Captivated center contacts.
- Spring fingers and center contacts are made from beryllium copper, heat treated and gold plated per ASTM-B-488; Type III, Code C
- SMA connector interface specification per MIL-STD-348A.
- Operating temperature range: -54°C to +115°C, units with extended temperature range are available on request.
- Physical length change per revolution of adjustment nut: ~ 0.5 mm
- Electrical length change per revolution of adjustment nut: ~ 0.5 mm
- Maximum change in physical length: 17.5 ± 0.25mm
- Maximum change in electrical length: 17.5 ± 0.25mm of air

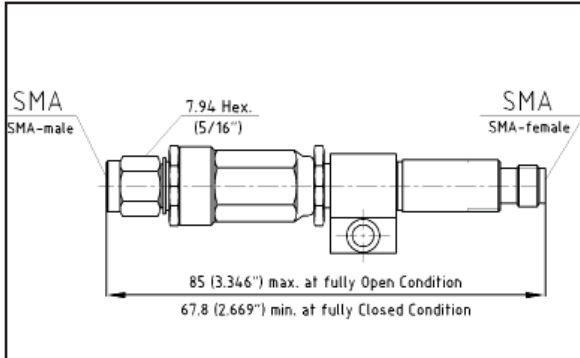

Part Number	Frequency Range	VSWR max.	Insertion Loss max.	Phase Shift min.	No. of Turns	Nom. Phase Shift Deg./GHz/Turn	Time Delay (psec.) min. max.	Weight max.
LS-0321-1121	DC-26.0 GHz	1.1+.008*f(GHz)	0.8 dB	500° at 26.0 GHz	35	0.6	236.7 290.5	30 g

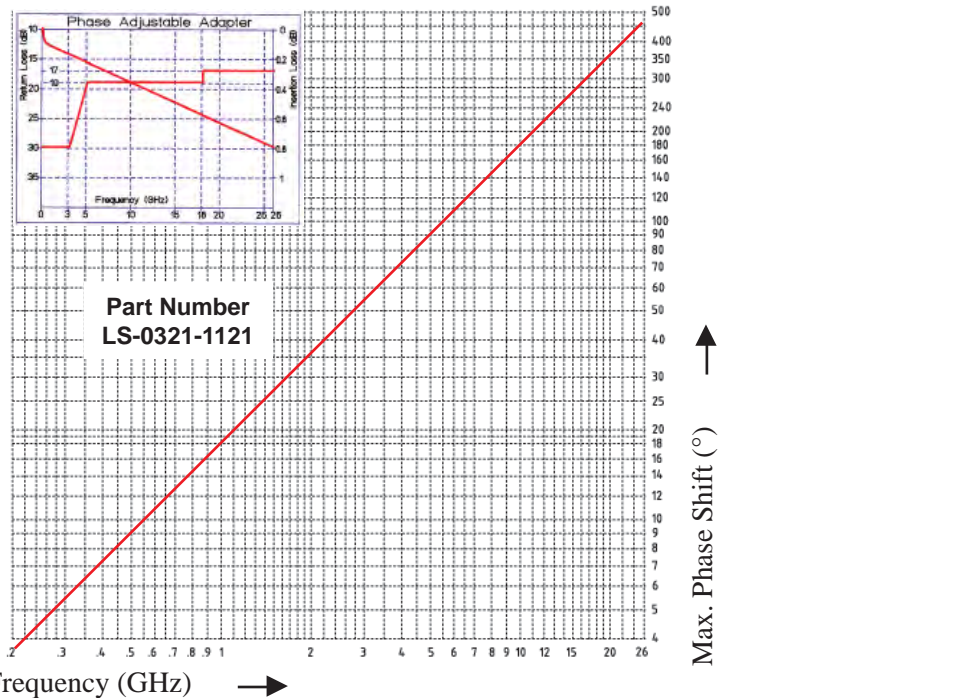

Adjusting Phase.indd.2014

DC to 26.0 GHz Phase Adjustable Adapter



- Developed for airborne applications, using locking screws for safe adjustment.
- Precision phase adjustable adapters, DC to 26.0 GHz.
- Impedance of 50 Ohms is maintained over the full adjustment range.
- Positive resettable locking mechanism.
- Smooth continuous phase adjustment.
- Physical length change of the unit equals the electrical length change.
- Rugged construction, housing and outer conductors are made from stainless steel.

- Captivated center contacts.
- Spring fingers and center contacts are made from beryllium copper, heat treated and gold plated per ASTM-B-488; Type III, Code C
- SMA connector interface specification per MIL-STD-348A.
- Operating temperature range: -54°C to +115°C, units with extended temperature range are available on request.
- Different connector configurations can be supplied on request.
- Physical length change per revolution of adjustment nut: ~ 0.5 mm
- Electrical length change per revolution of adjustment nut: ~ 0.5 mm
- Maximum change in physical length: 5 ± 0.25mm
- Maximum change in electrical length: 5 ± 0.25mm of air

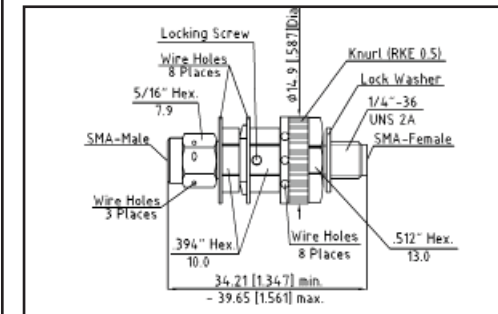

Part Number	Frequency Range	VSWR max.	Insertion Loss max.	Phase Shift min.	No. of Turns	Nom. Phase Shift Deg./GHz/Turn	Time Delay (psec.) min. max.	Weight max.
LS-S008-1121	DC-26.0 GHz	1.5:1	0.4 dB	155° at 26.5 GHz	10	0.60	118.6 135.1	19.4 g

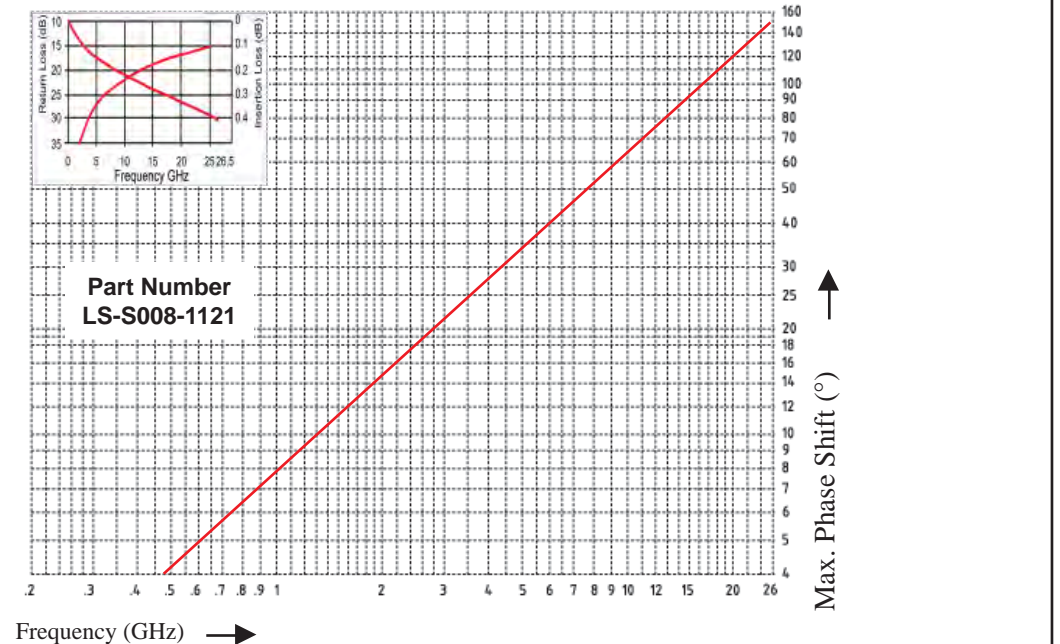

Adjusting Phase.indd.2014

Phase Adjustable Adapter DC to 18.0 GHz



DC to 18.0 GHz Phase Adjustable Adapter

- Precision phase adjustable adapters, DC to 18.0 GHz.
- Impedance of 50 Ohms is maintained over the full adjustment range.
- High power solution available.
- Positive resettable locking mechanism.
- Smooth continuous phase adjustment.
- Physical length change of the unit equals the electrical length change.
- Rugged construction, housing and outer conductors are made from stainless steel.
- Captivated center contacts
- Spring fingers and center contacts are made from beryllium copper, heat treated and gold plated per ASTM-B-488; Type III, Code C
- N connector interface specification per MIL-STD-348A.
- Operating temperature range: -65°C to +70°C, units with extended temperature range are available on request.
- Mounting Brackets are optional and are shown on the drawings on the next page.
- Diagram Phase Shift (°) vers. Frequency (GHz), please refer to page D9.

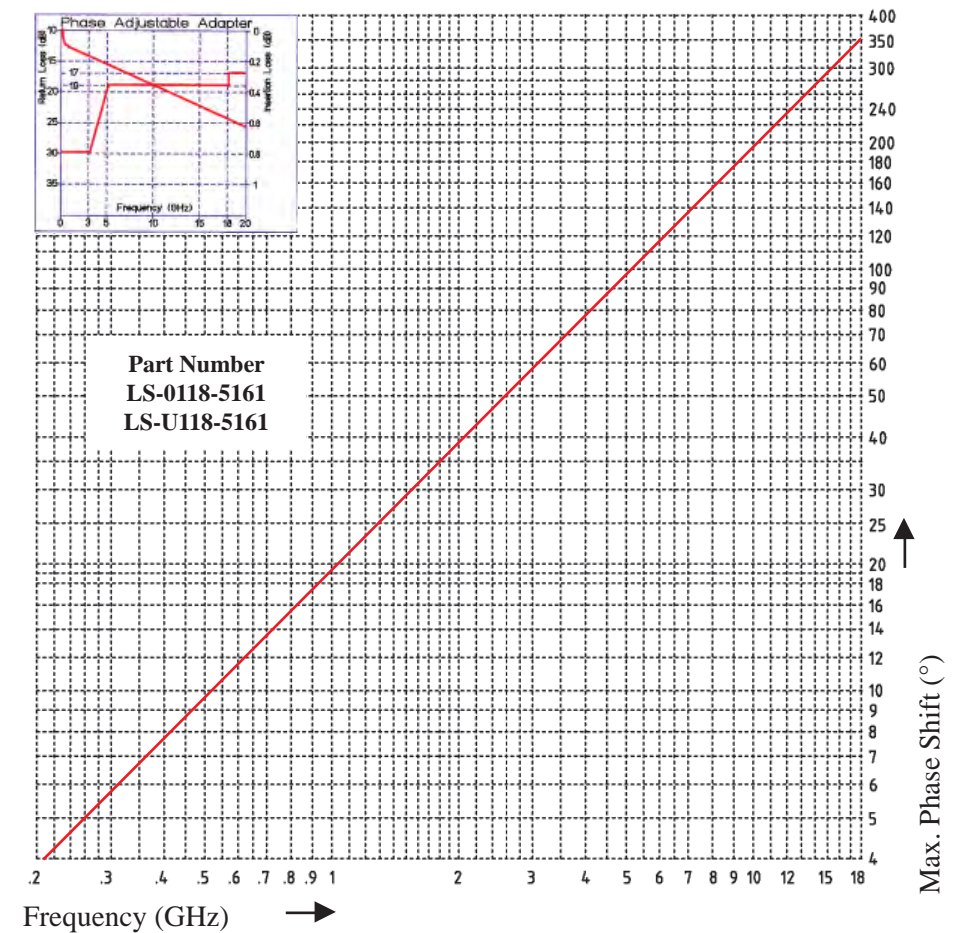
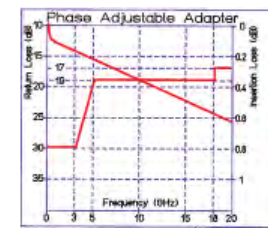
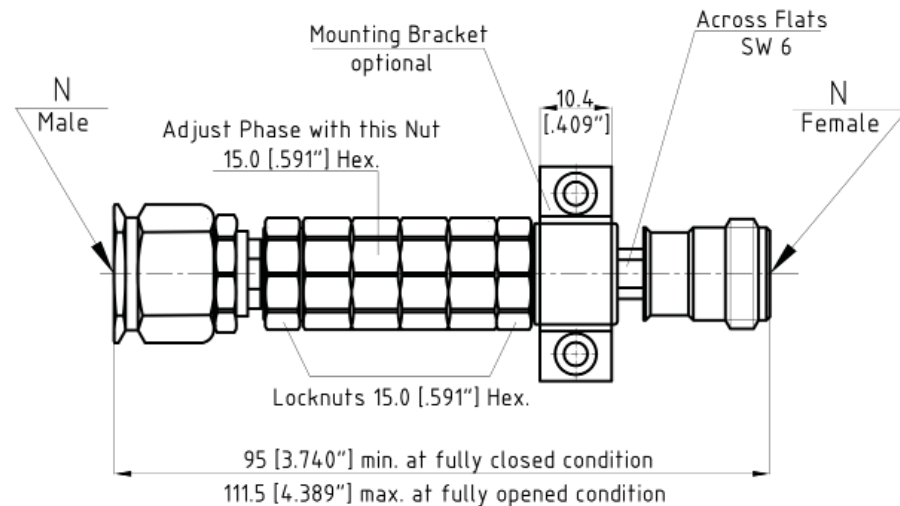

Part Number
LS-0118-5161
LS-U118-5161

Two different Mounting Brackets are offered. They can easily be added to any Precision Phase Adjuster. Using these standard attachments makes it easy to mount the Phase Shifter in the system or to the test setup and ensures proper operation.

mounting at only one side

mounting at both sides

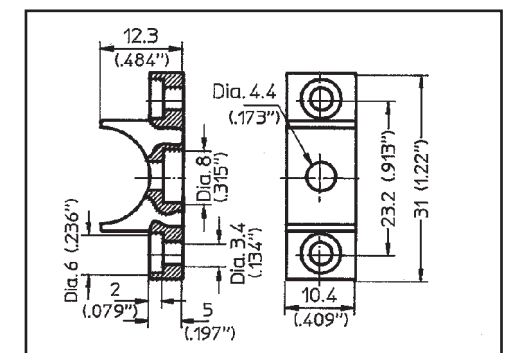
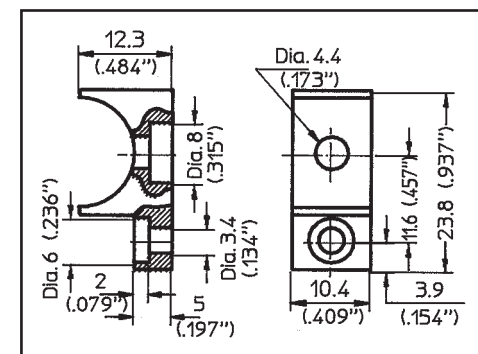

Bracket, Part No.: MB-0100-07
 Material: Aluminum iridited

Bracket, Part No.: MB-0200-07
 Material: Aluminum iridited

Part Number	Temperature Range	Frequency Range	VSWR max.	Insertion Loss max.	Phase Shift min.	No. of Turns	Nom. Phase Shift Deg./GHz/ Turn	Time Delay (psec.) min. max.	Weight max.
LS-0112-5161 LS-U112-5161	-65° to +70° C -65° to +165° C	DC - 12.0 GHz	1.25:1	0.3 dB	230° at 12.0 GHz	16.5	1.2	300 355	105 g
LS-0118-5161 LS-U118-5161		DC - 18.0 GHz		0.5 dB	350° at 18.0 GHz				

Phase Adjustable Adapter DC to 18.0 GHz



DC to 18.0 GHz Phase Adjustable Adapter

- Precision phase adjustable adapters, DC to 18.0 GHz.
- Impedance of 50 Ohms is maintained over the full adjustment range.
- High power solution available.
- Positive resettable locking mechanism.
- Smooth continuous phase adjustment.
- Physical length change of the unit equals the electrical length change.
- Rugged construction, housing and outer conductors are made from stainless steel.
- Captivated center contacts
- Spring fingers and center contacts are made from beryllium copper, heat treated and gold plated per ASTM-B-488; Type III Code C
- TNC connector interface specification per MIL-STD-348A.
- Operating temperature range: -65°C to +70°C, units with extended temperature range are available on request.
- Mounting Brackets are optional and are shown on the drawings on the next page.

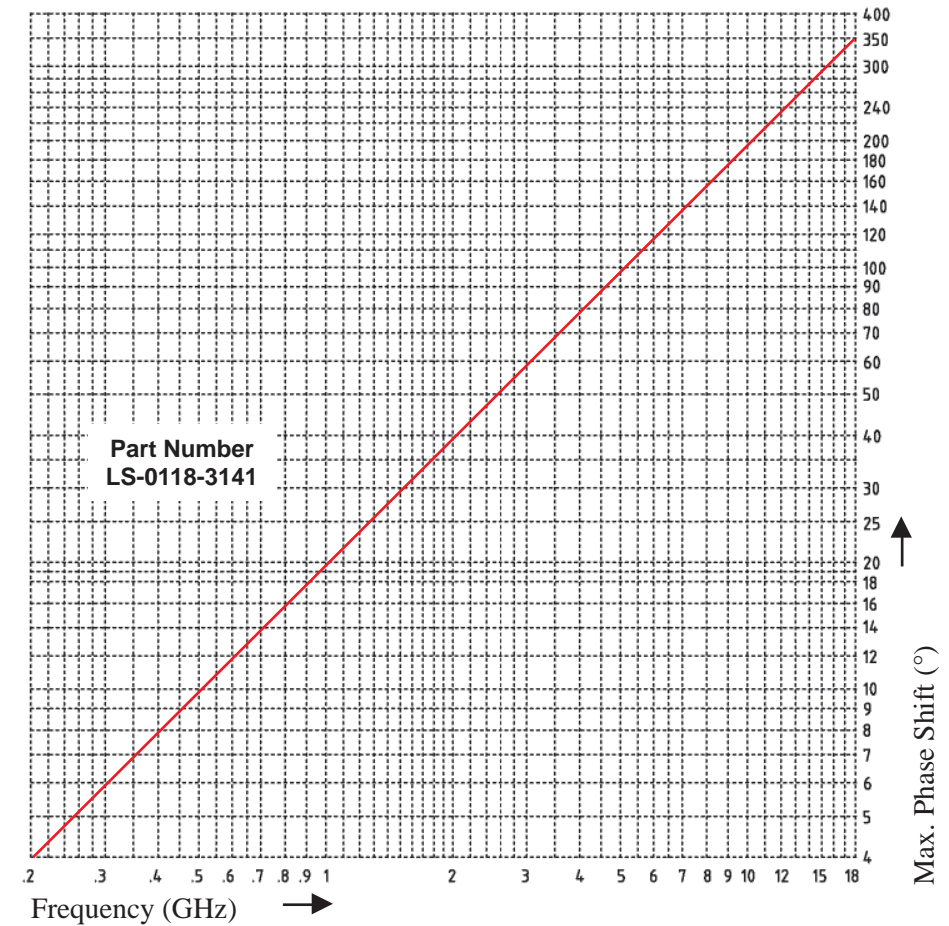
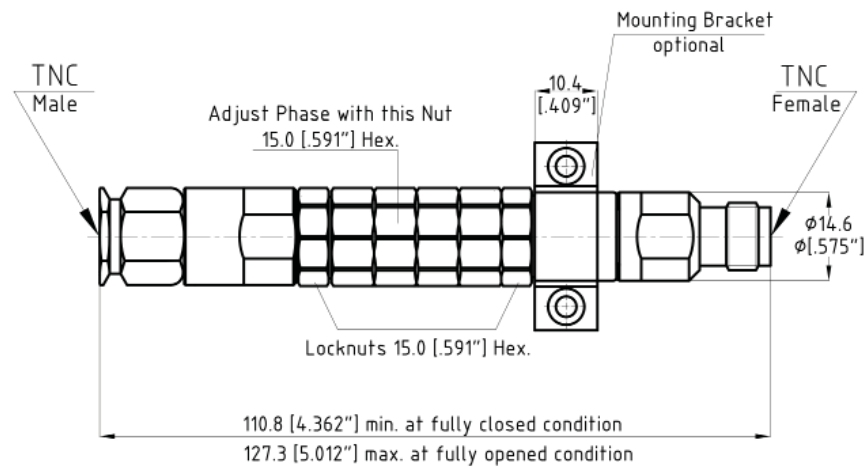

Two different Mounting Brackets are offered. They can easily be added to any Precision Phase Adjuster. Using these standard attachments makes it easy to mount the Phase Shifter in the system or to the test setup and ensures proper operation.

mounting at only one side

mounting at both sides

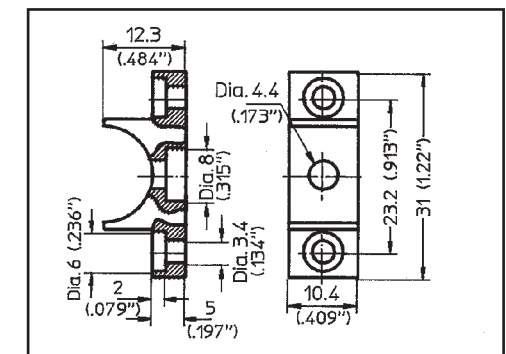
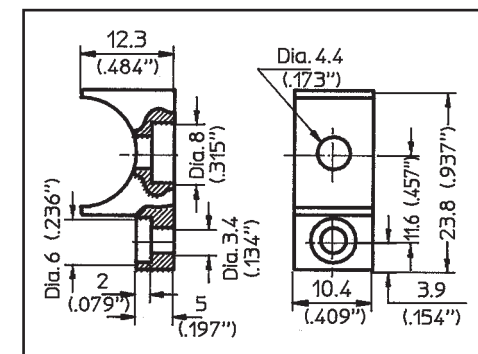

Bracket, Part No.: MB-0100-07
Material: Aluminum iridited

Bracket, Part No.: MB-0200-07
Material: Aluminum iridited

Part Number	Frequency Range	VSWR max.	Insertion Loss max.	Phase Shift min.	No. of Turns	Nom. Phase Shift Deg./GHz/ Turn	Time Delay (psec.)		Weight max.
							min.	max.	
LS-0118-3141	DC - 18.0 GHz	1.25:1	0.5 dB	335° at 18.0 GHz	16.5	1.2	379.9	435	115 g

Phase Adjustable Adapter DC to 28.0 GHz



DC to 28.0 GHz Phase Adjustable Adapter

- Precision phase adjustable adapters, DC to 28.0 GHz.
- Impedance of 50 Ohms is maintained over the full adjustment range.
- High power solution available.
- Positive resettable locking mechanism.
- Smooth continuous phase adjustment.
- Physical length change of the unit equals the electrical length change.
- Rugged construction, housing and outer conductors are made from stainless steel.
- Captivated center contacts
- Spring fingers and center contacts are made from beryllium copper, heat treated and gold plated per ASTM-B-488; Type III Code C
- 2.92mm connector interface specification per MIL-STD-348A.
- Operating temperature range: -54°C to +115°C, units with extended temperature range are available on request.

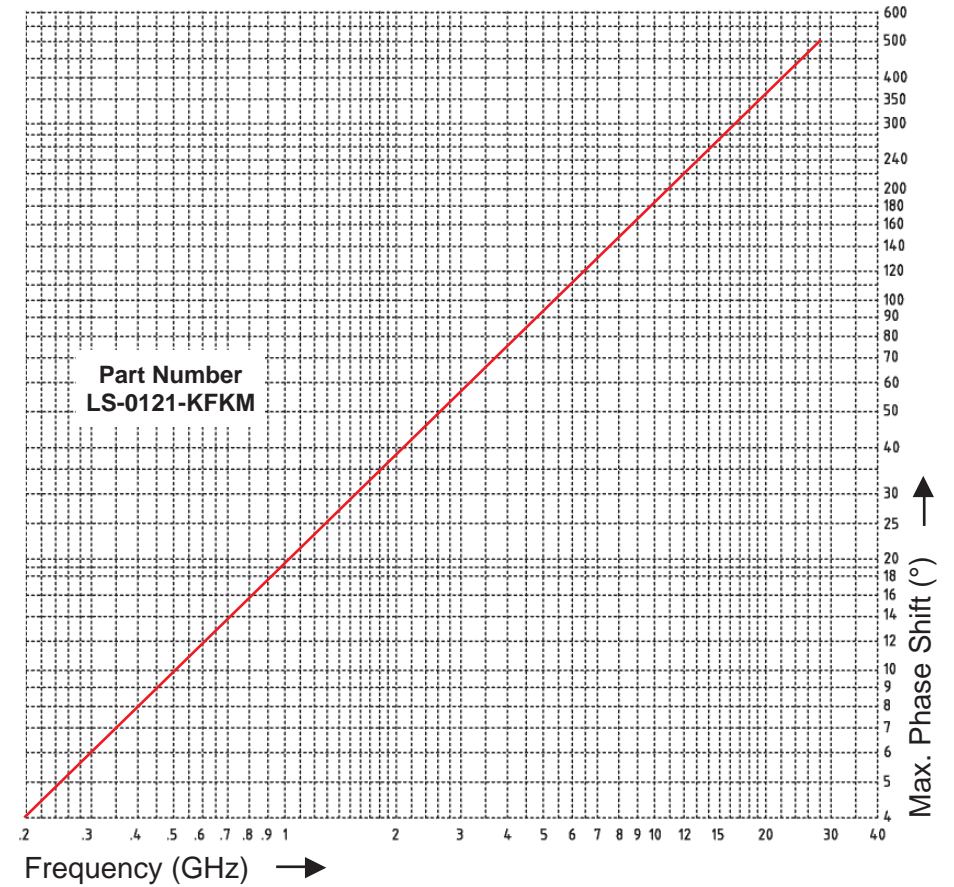
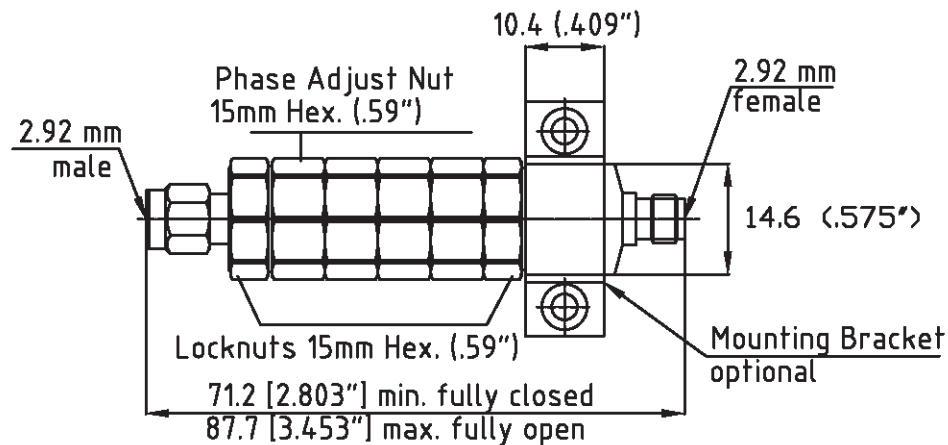

Two different Mounting Brackets are offered. They can easily be added to any Precision Phase Adjuster. Using these standard attachments makes it easy to mount the Phase Shifter in the system or to the test setup and ensures proper operation.

mounting at only one side

mounting at both sides

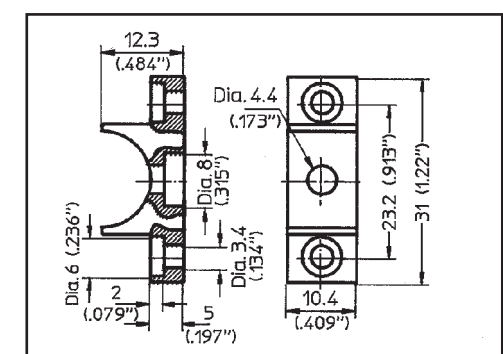
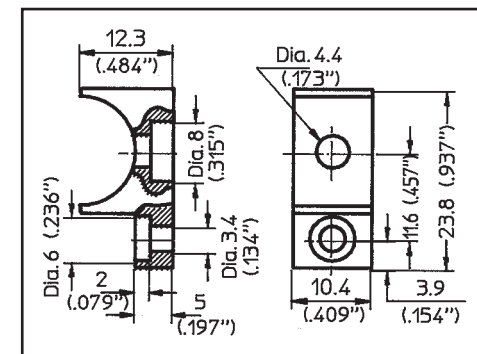

Bracket, Part No.: MB-0100-07
Material: Aluminum iridited

Bracket, Part No.: MB-0200-07
Material: Aluminum iridited

Part Number	Frequency Range	VSWR max.	Insertion Loss max.	Phase Shift min.	No. of Turns	Nom. Phase Shift Deg./GHz/ Turn	Time Delay (psec.) min. max.	Weight max.
LS-0121-KFKM	DC - 28.0 GHz	1.25:1	0.6 dB	510° at 28.0 GHz	16.5	1.2	288 343.1	65 g

Adjusting Phase.indd.2014

Adjusting Phase.indd.2014

Phase Adjustable Adapter DC to 40.0 GHz



- Precision phase adjustable adapters, DC to 40.0 GHz.
- Impedance of 50 Ohms is maintained over the full adjustment range.
- Positive resettable locking mechanism.
- Smooth continuous phase adjustment.
- Physical length change of the unit equals the electrical length change.
- Rugged construction, housing and outer conductors are made from stainless steel.
- Besides the Standard Units, High Precision Components are offered, showing superior electrical performance to 40.0 GHz, being easily identified by their gold plated body.
- Bead captivated center contacts.
- Spring fingers and center contacts are made from beryllium copper, heat treated and gold plated per ASTM-B-488; Type III, Code C
- 2.92 mm (K) connector interface specification per MIL-STD-348A.
- Operating temperature range: -54°C to +85°C.
- Mounting Brackets are optional and are shown on the drawings below and to the right.

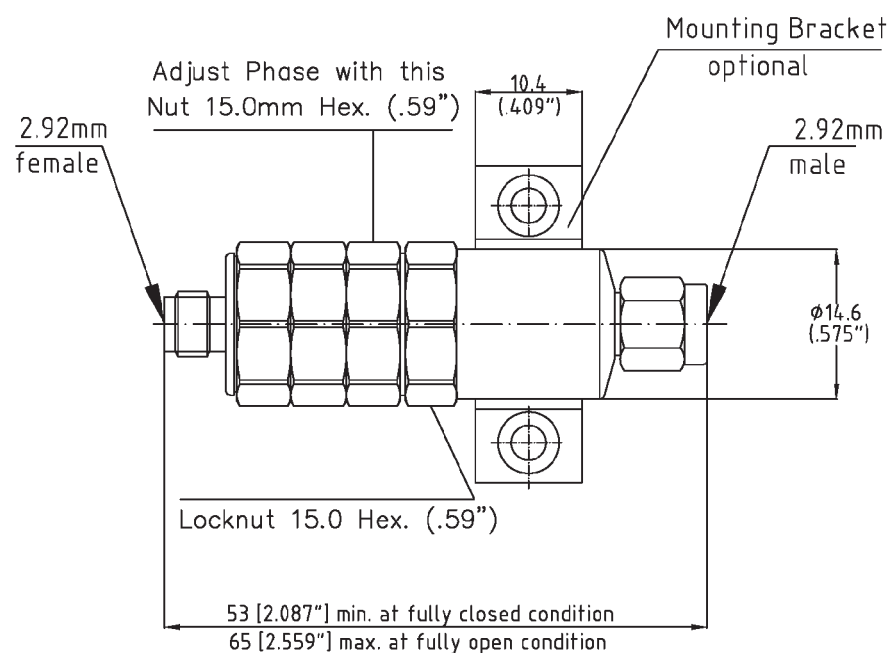

Part Number	Frequency Range	VSWR max.	Insertion Loss max.	Phase Shift min.	No. of Turns	Nom. Phase Shift Deg./GHz/Turn	Time Delay (psec.) min. max.	Weight max.
LS-0140-KFKF LS-0140-KFKM	DC - 40.0 GHz	1.40:1	0.65 dB	550° at 40.0 GHz	12	1.15	168 208	49 g
LS-P140-KFKF LS-P140-KFKM		1.20:1						51 g

Adjusting Phase.indd.2014



DC to 40.0 GHz Phase Adjustable Adapter

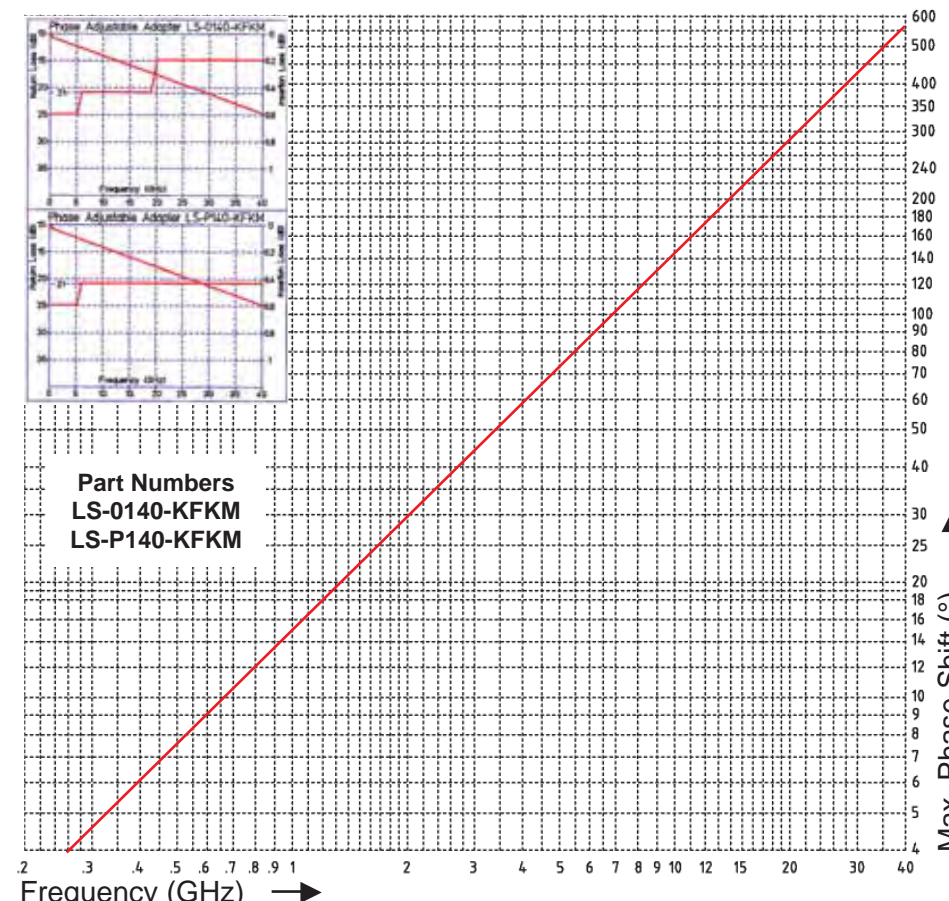

Adjusting Phase.indd.2014



LS-0140-KFKM

- Precision phase adjustable adapters, DC to 40.0 GHz.
- Impedance of 50 Ohms is maintained over the full adjustment range.
- Positive resettable locking mechanism.
- Smooth continuous phase adjustment.
- Physical length change of the unit equals the electrical length change.
- Rugged construction, housing and outer conductors are made from stainless steel.
- Besides the Standard Units, High Precision Components are offered, showing superior electrical performance to 40.0 GHz, being easily identified by their gold plated body.
- Bead captivated center contacts.
- Spring fingers and center contacts are made from beryllium copper, heat treated and gold plated per ASTM-B-488; Type III Code C
- 2.92 mm (K) connector interface specification per MIL-STD-348A.
- Operating temperature range: -54°C to +85°C.
- Mounting Brackets are optional and are shown on the drawings at pages D28 and D29.

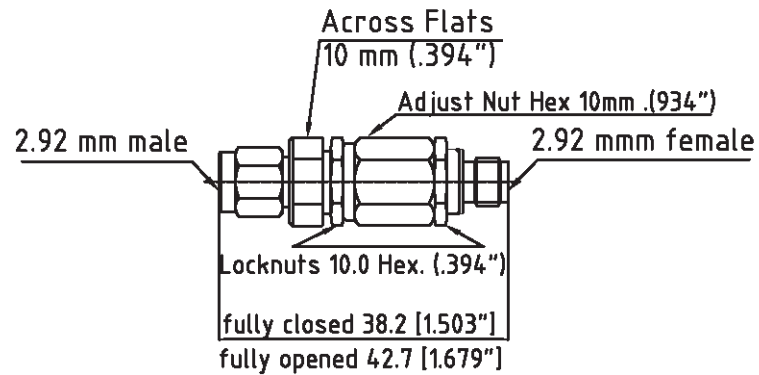

Part Number	Frequency Range	VSWR max.	Insertion Loss max.	Phase Shift min.	No. of Turns	Nom. Phase Shift Deg./GHz/ Turn	Time Delay (psec.) min. max.	Weight max.
LS-0040-KFKF	DC - 40.0 GHz	1.35	0.65	210° at 40.0 GHz	9	0.58	t.b.d.	16
LS-P040-KFKF		1.20						
LS-0040-KFKM		1.35						
LS-P040-KFKM		1.20						
LS-0040-KMKM		1.35						
LS-P040-KMKM		1.20						

Adjusting Phase.indd.2014

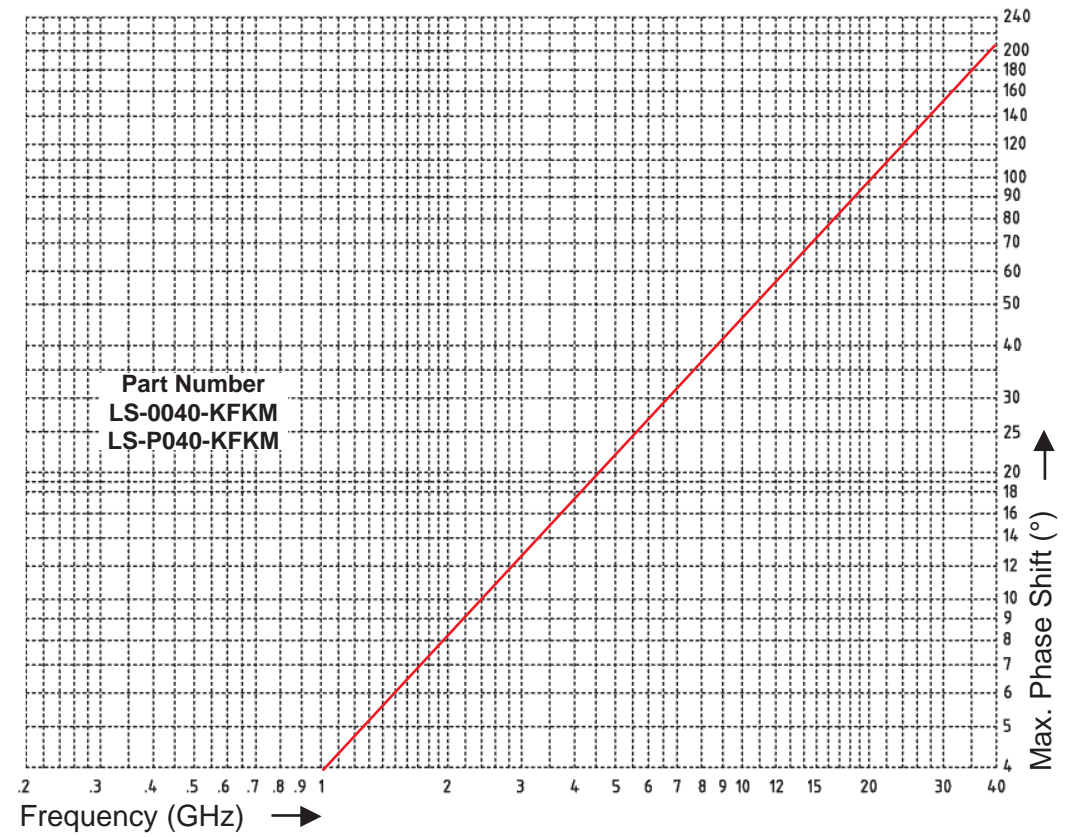

Adjusting Phase.indd.2014



LS-0040-KFKM

Phase Adjustable Adapter DC to 50.0 GHz



DC to 50.0 GHz Phase Adjustable Adapter

- Precision phase adjustable adapters, DC to 50.0 GHz.
- Impedance of 50 Ohms is maintained over the full adjustment range.
- Positive resettable locking mechanism.
- Smooth continuous phase adjustment.
- Physical length change of the unit equals the electrical length change.
- Rugged construction, housing and outer conductors are made from stainless steel.
- Besides the Standard Units, High Precision Components are offered, showing superior electrical performance to 50.0 GHz, being easily identified by their gold plated body.
- Bead captivated center contacts.
- Spring fingers and center contacts are made from beryllium copper, heat treated and gold plated per AST-B-488; Type III, Code C
- 2.4 mm connector interface specification per MIL-STD-348A.
- Operating temperature range: -54°C to +85°C.
- Mounting Brackets are optional and are shown on the drawings below and to the right.

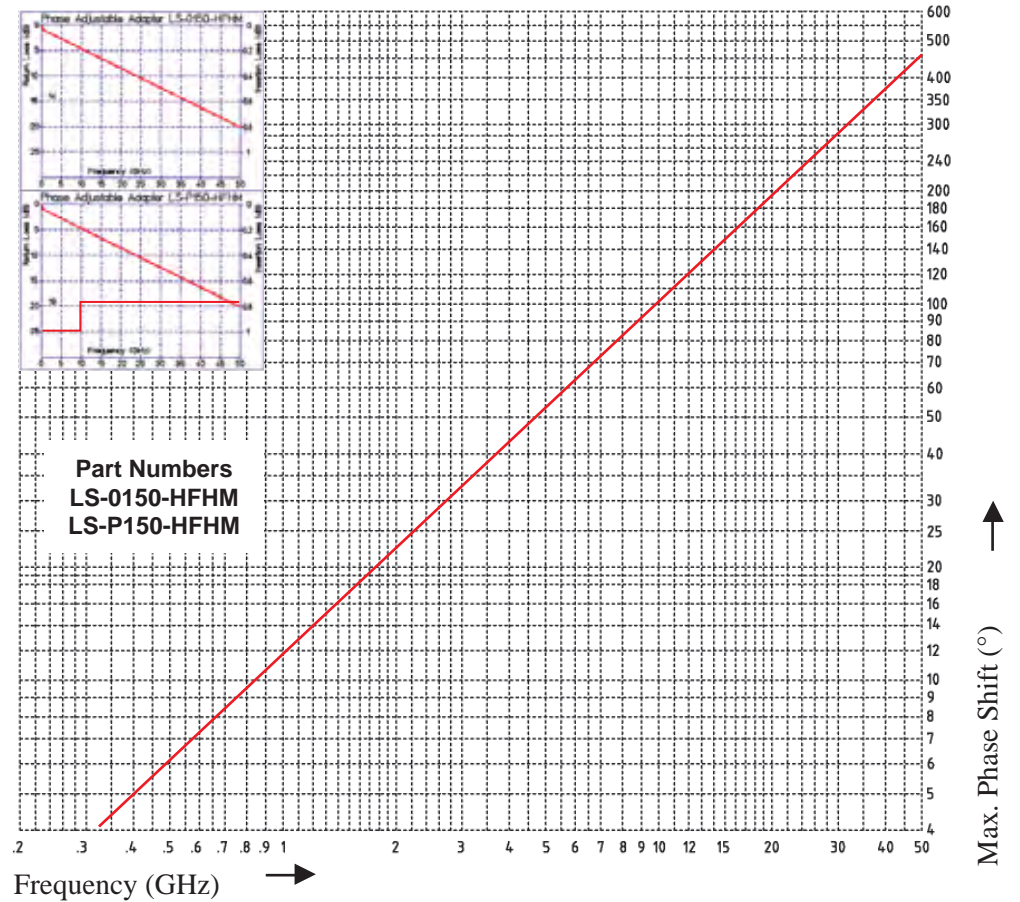
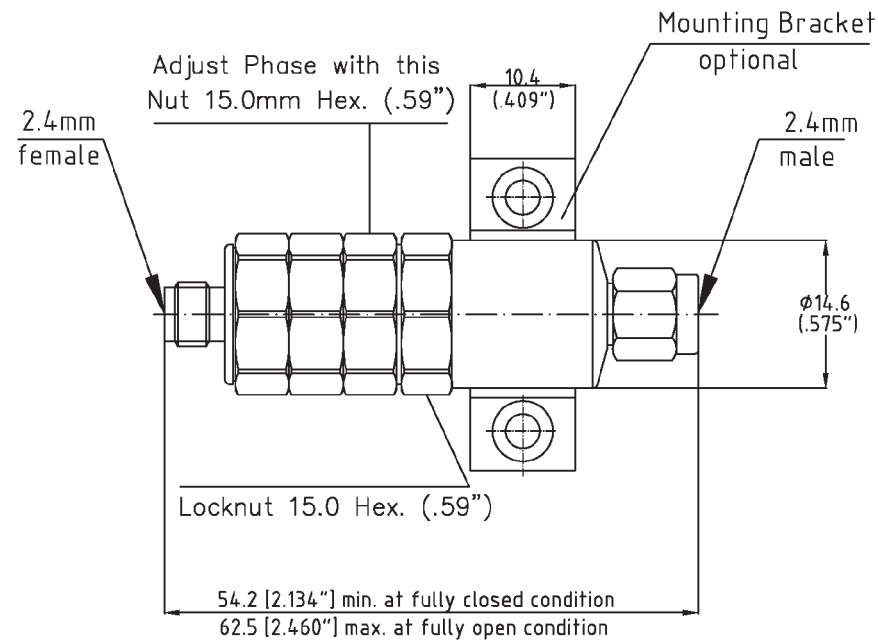

Part Number	Frequency Range	VSWR max.	Insertion Loss max.	Phase Shift min.	No. of Turns	Nom. Phase Shift Deg./GHz/ Turn	Time Delay (psec.) min. max.	Weight max.
LS-0150-HFHF LS-P150-HFHF	DC - 50.0 GHz	1.50:1	0.8 dB	450° at 50.0 GHz	8	1.2	172 195	53 g
LS-0150-HFHM LS-P150-HFHM		1.30:1						55 g

Adjusting Phase.indd.2014

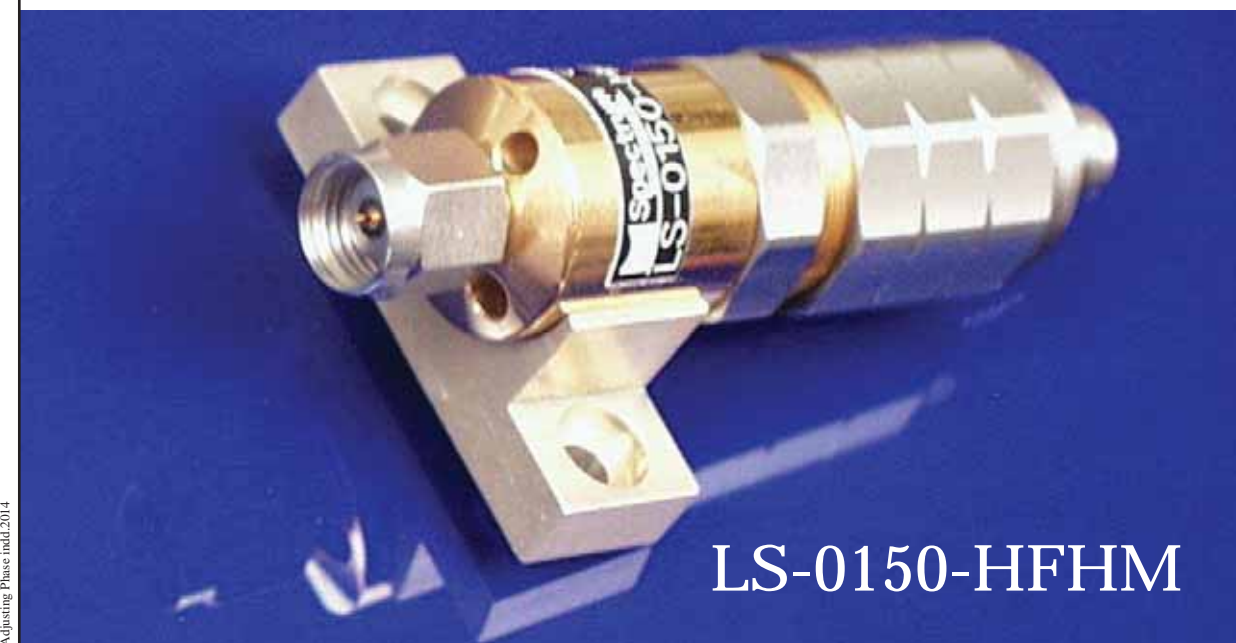

- Precision phase adjustable adapters, DC to 50.0 GHz.
- Impedance of 50 Ohms is maintained over the full adjustment range.
- Positive resettable locking mechanism.
- Smooth continuous phase adjustment.
- Physical length change of the unit equals the electrical length change.
- Rugged construction, housing and outer conductors are made from stainless steel.
- Besides the Standard Units, High Precision Components are offered, showing superior electrical performance to 50.0 GHz, being easily identified by their gold plated body.
- Bead captivated center contacts.
- Spring fingers and center contacts are made from beryllium copper, heat treated and gold plated per AST-B-488; Type III, Code C
- 2.4 mm connector interface specification per MIL-STD-348A.
- Operating temperature range: -54°C to +85°C.
- Mounting Brackets are optional and are shown on pages D28 and D29.

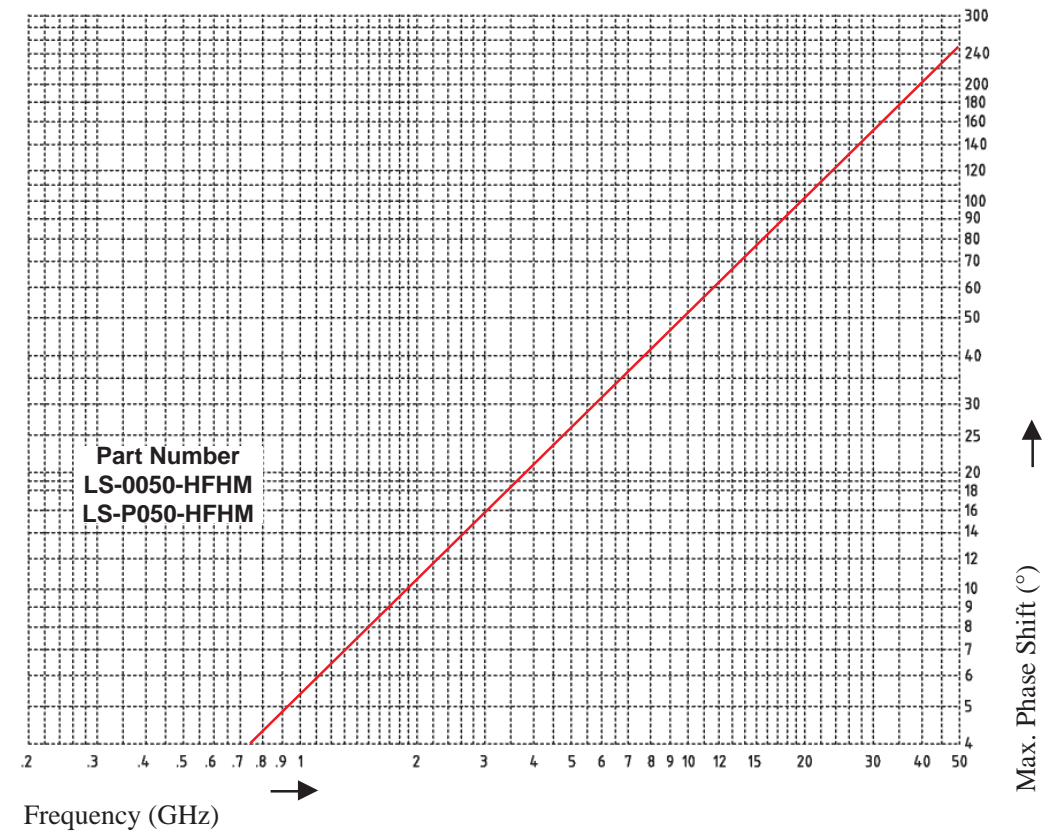
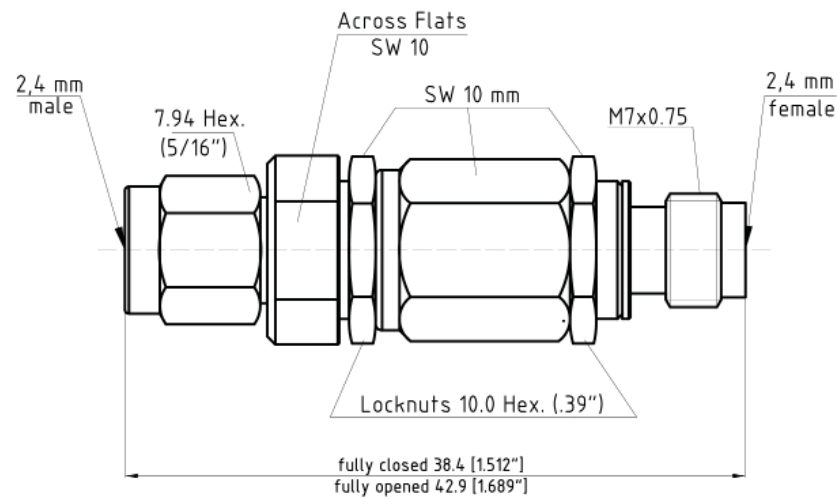

LS-0050-HFHM

Part Number	Frequency Range	VSWR max.	Insertion Loss max. (dB)	Phase Shift min.	No. of Turns	Nom. Phase Shift Deg./GHz/ Turn	Time Delay (psec.) min. max.	Weight max. (g)
LS-0050-HFHM LS-P050-HFHM	DC - 50.0 GHz	1.4:1 1.2:1	0.7	240° at 50.0 GHz	9	0.53	t.b.d.	16.

Adjusting Phase.indd.2014

Adjusting Phase.indd.2014

- Precision phase adjustable adapters, DC to 50.0 GHz.
- Impedance of 50 Ohms is maintained over the full adjustment range.
- Positive resettable locking mechanism.
- Smooth continuous phase adjustment.
- Physical length change of the unit equals the electrical length change.
- Rugged construction, housing and outer conductors are made from stainless steel.
- Besides the Standard Units, High Precision Components are offered, showing superior electrical performance to 50.0 GHz, being easily identified by their gold plated body.
- Bead captivated center contacts.
- Spring fingers and center contacts are made from beryllium copper, heat treated and gold plated per AST-B-488; Type III, Code C
- 2.4 mm connector interface specification per MIL-STD-348A.
- Operating temperature range: -54°C to +85°C.
- Mounting Brackets are optional and are shown on the drawings at pages D28 and D29

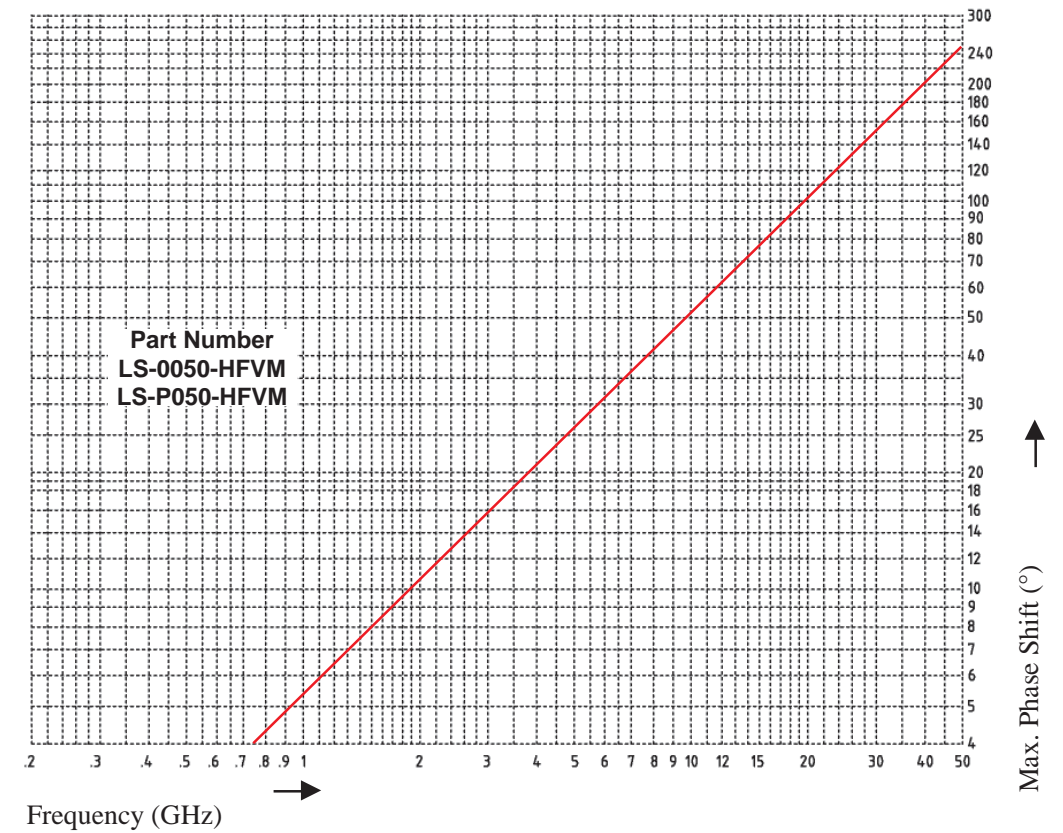
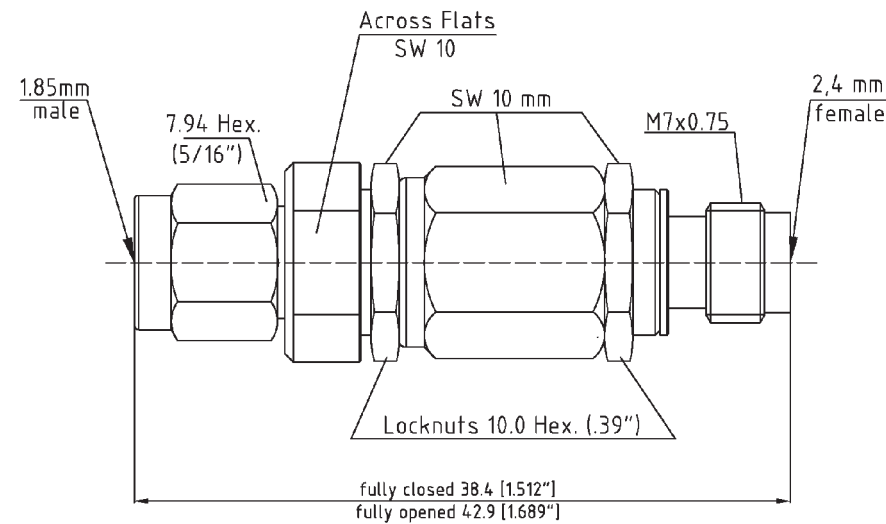

LS-0050-HFVM

Part Number	Frequency Range	VSWR max.	Insertion Loss max.	Phase Shift min.	No. of Turns	Nom. Phase Shift Deg./GHz/ Turn	Time Delay (psec.)		Weight max.
							min.	max.	
LS-0050-HFVM LS-P050-HFVM	DC - 50.0 GHz	1.4:1 1.2:1	0.7	240 at 50.0 GHz	9	0.53	114	126.	16.5

Adjusting Phase.indd.2014

Adjusting Phase.indd.2014

Phase Adjustable Adapter DC to 63.0 GHz



DC to 63.0 GHz Phase Adjustable Adapter

- Precision phase adjustable adapters, DC to 63.0 GHz.
- Impedance of 50 Ohms is maintained over the full adjustment range.
- Positive resettable locking mechanism.
- Smooth continuous phase adjustment.
- Physical length change of the unit equals the electrical length change.
- Rugged construction, housing and outer conductors are made from stainless steel.
- Besides the Standard Units, High Precision Components are offered, showing superior electrical performance to 63.0 GHz, being easily identified by their gold plated body.
- Bead captivated center contacts.
- Spring fingers and center contacts are made from beryllium copper, heat treated and gold plated per AST-B-488; Type III, Code C
- The product is needed for adjusting the electrical lengths of lines in applications where data rates of 40 GBit/sec and above are being transferred in optical systems
- Operating temperature range: -54°C to +85°C.
- Mounting Brackets are optional and are shown on the drawings to the right.

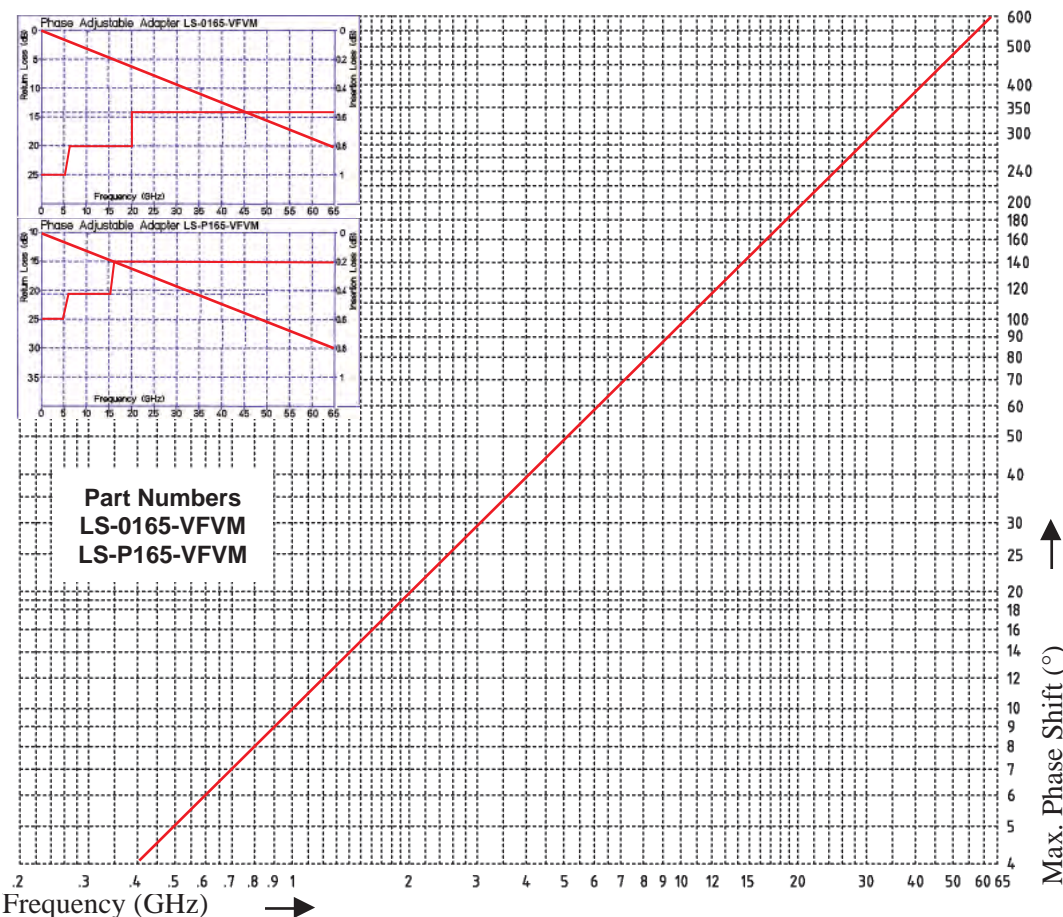
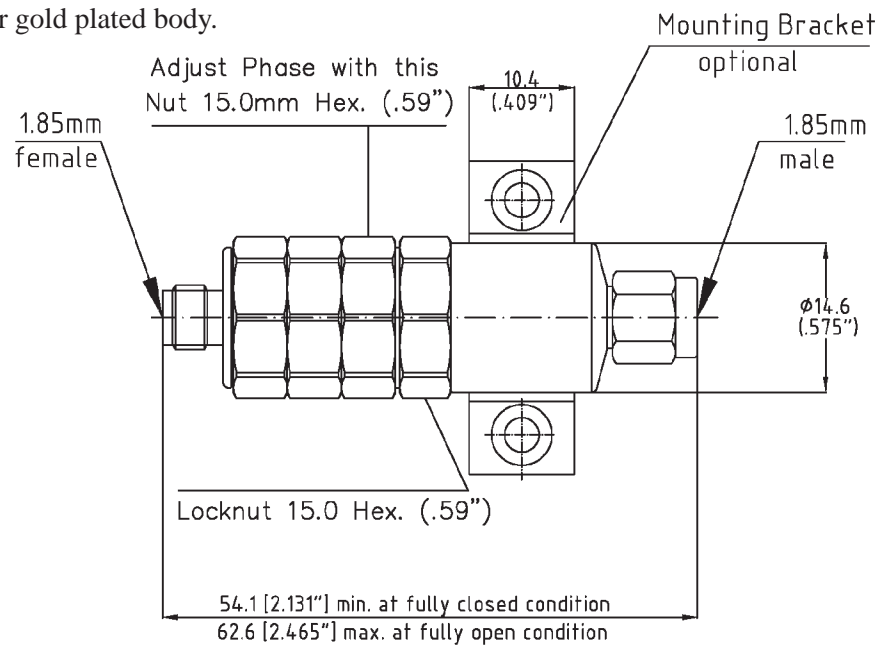

Two different Mounting Brackets are offered. They can easily be added to any Precision Phase Adjuster. Using these standard attachments makes it easy to mount the Phase Shifter in the system or to the test setup and ensures proper operation.

mounting at only one side

mounting at both sides

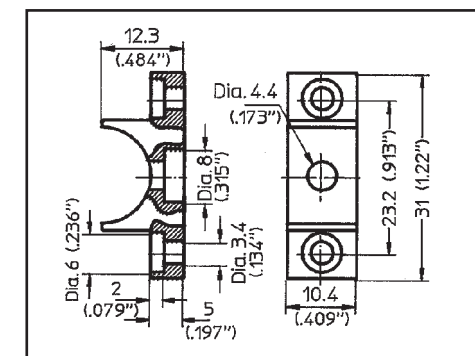
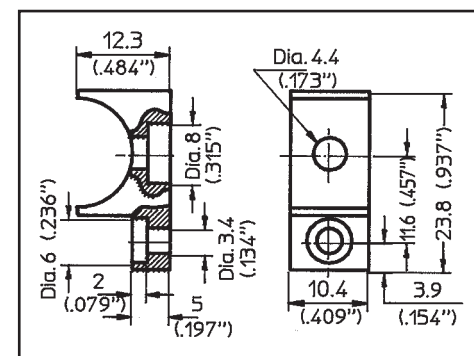

Bracket, Part No.: MB-0100-07
Material: Aluminum iridited

Bracket, Part No.: MB-0200-07
Material: Aluminum iridited

Part Number	Frequency Range	VSWR max.	Insertion Loss max.	Phase Shift min.	No. of Turns	Nom. Phase Shift Deg./GHz/ Turn	Time Delay (psec.) min. max.	Weight max.
LS-0165-VFVF LS-0165-VFVM LS-0165-VMVM	DC - 63.0 GHz	1.50:1	0.8 dB	600° at 63.0 GHz	8	1.2	167 195	53 g
LS-P165-VFVF LS-P165-VFVM LS-P165-VMVM		1.40:1						55 g

- Precision phase adjustable adapters, DC to 63.0 GHz.
- Impedance of 50 Ohms is maintained over the full adjustment range.
- Positive resettable locking mechanism.
- Smooth continuous phase adjustment.
- Physical length change of the unit equals the electrical length change.
- Rugged construction, housing and outer conductors are made from stainless steel.
- Bead captivated center contacts.
- Spring fingers and center contacts are made from beryllium copper, heat treated and gold plated per AST-B-488; Type III, Code C
- The product is needed for adjusting the electrical lengths of lines in applications where data rates 40 GBit/sec and above are being transferred in optical systems
- Operating temperature range: -54°C to +85°C.
- Mounting Brackets are optional and are shown on the drawings at pages D28 and D29 .

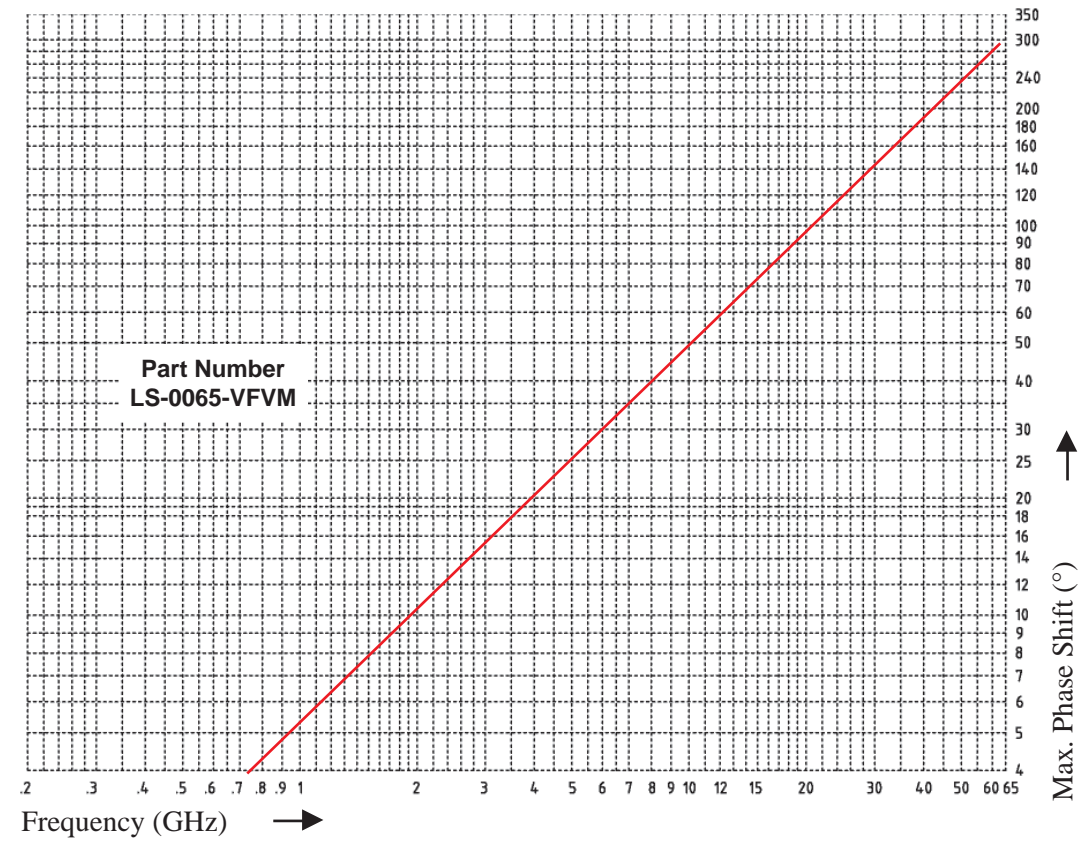
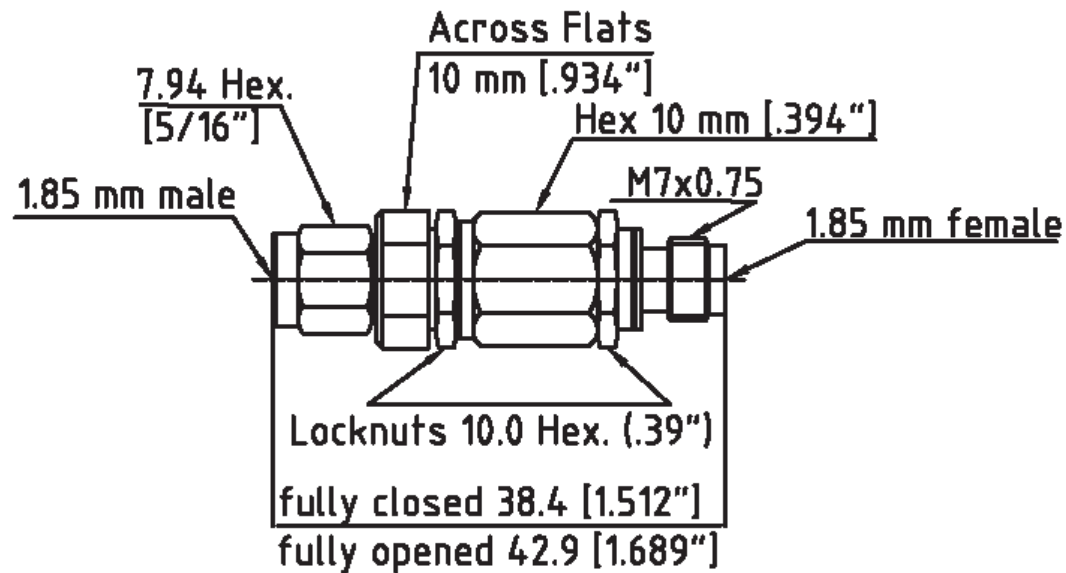

LS-0065-VFVM

Part Number	Frequency Range	VSWR max.	Insertion Loss max.	Phase Shift min.	No. of Turns	Nom. Phase Shift Deg./GHz/ Turn	Time Delay (psec.) min. max.	Weight max.
LS-0065-VFVM LS-P065-VFVM	DC - 63.0 GHz	1.5:1 1.3:1	0.8 dB	275° at 63.0 GHz	8	0.545	113.5 126	16 g

Adjusting Phase.indd.2014

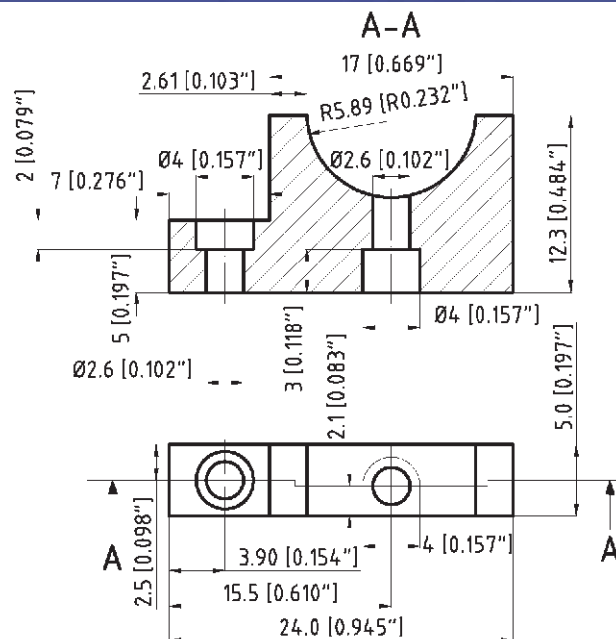

mounting at both sides

Bracket, Part No.: MB-0300-07
Material: Aluminum iridited

2 different Mounting Brackets are offered. They can easily be added to any Precision Phase Adjuster. Using these standard attachments makes it easy to mount the Phase Shifter in the system or to the test setup and ensures proper operation.

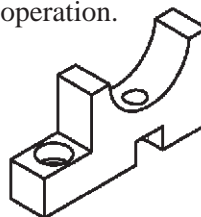

Adjusting Phase.indd.2014

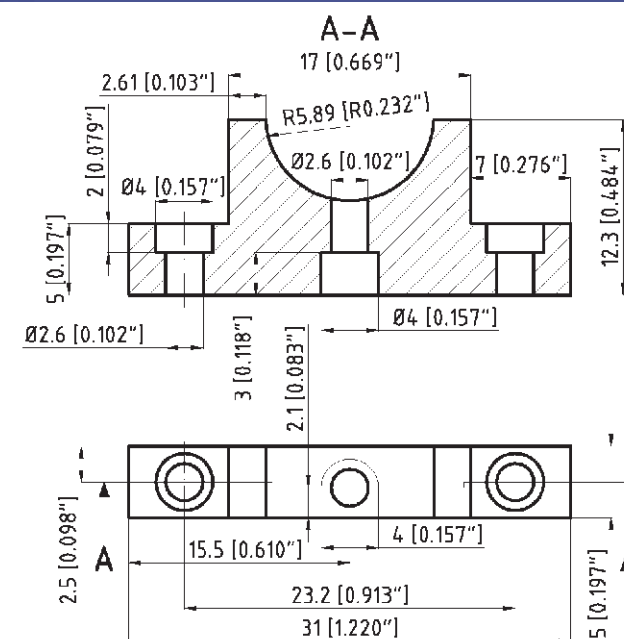

mounting at only one side

Bracket, Part No.: MB-0400-07
Material: Aluminum iridited

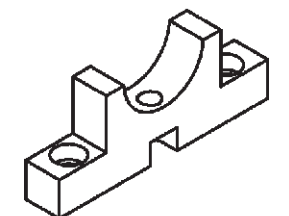

Adjusting Phase.indd.2014



13 Adapters SMA m/f of different lengths are available for phase matching.

Adjusting Phase.indd.2014

5/16" Hex. 7.94 .276" Hex. 7.0 1/4"-36 UNS-2A

SMA Male 2 Across Flats SMA Female

Part Number	Length L in inches	Length L in mm
8035-1121-05	0.948	24.08
8040-1121-05	1.058	26.88
8045-1121-05	1.163	29.53
8050-1121-05	1.270	32.25
8055-1121-05	1.377	34.98
8060-1121-05	1.489	37.83
8065-1121-05	1.597	40.56
8070-1121-05	1.707	43.35
8075-1121-05	1.813	46.04
8080-1121-05	1.921	48.79
8085-1121-05	2.029	51.54
8090-1121-05	2.135	54.24
8095-1121-05	2.246	57.05

Adjusting Phase.indd.2014



Adjusting Phase.indd.2014



Adjusting Phase.indd.2014

Trombone Line Phase Adjusters

Trombone Line Phase Adjusters are needed at lower frequency applications. They are designed for constant impedance over the whole adjustment range and to accommodate the electrical separation of the other components without introducing additional mismatch. All step discontinuities have been carefully compensated. Locking screws are provided to comfort the sliding tension and to lock at the desired adjustment. The best materials have been used, beryllium copper contacts assuring long life and noise-free operation, aluminum, brass and stainless steel parts for low weight, best performance and ruggedness. Stops at both ends of travel are preventing damage of the unit and do not allow accidental disassembly.

Trombone Line Phase Adjusters

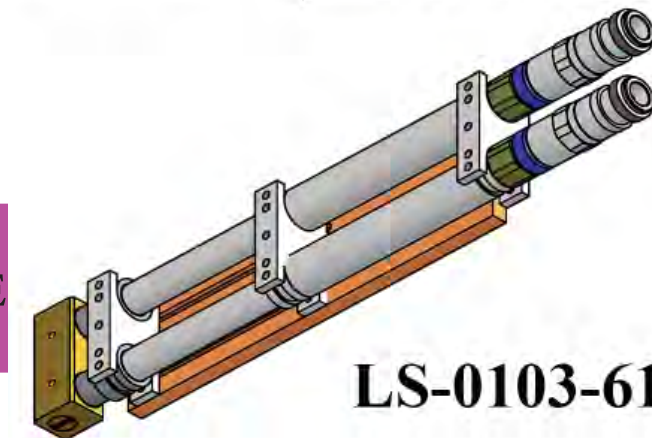
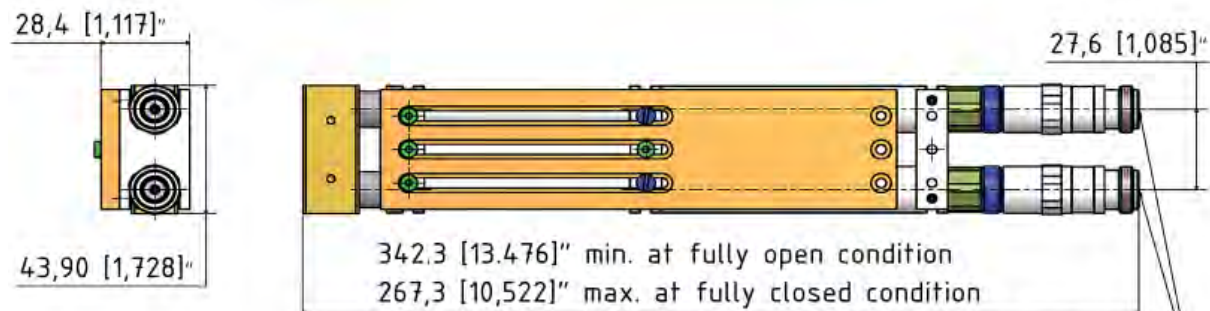

LS-0103-6161

Frequency Range: DC to 3.0 GHz
 VSWR max: 1.2:1
 Insertion Loss max.: 0.6 dB
 Phase Shift max.: 180° at 1.0 GHz

TYPE N-FEMALE
 INTERFACE
 PER MIL-348A

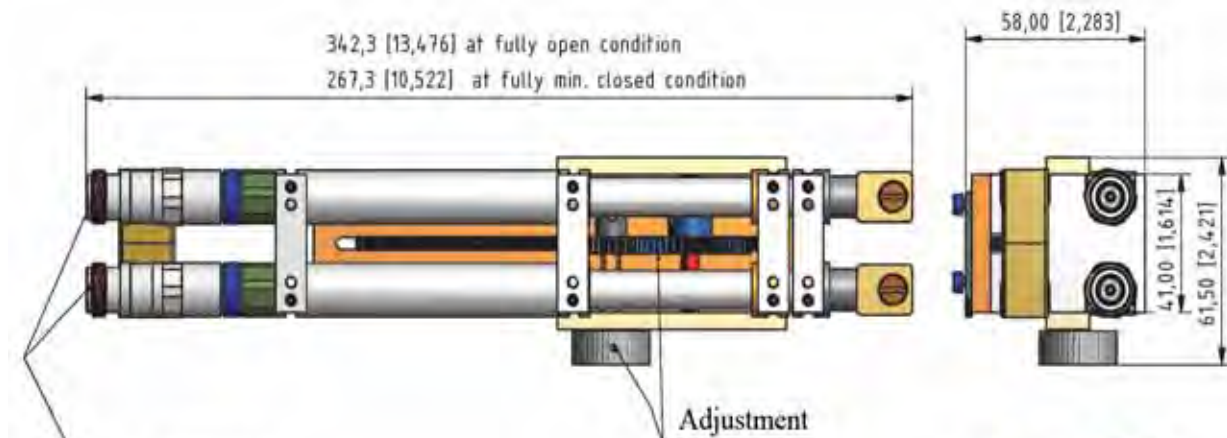

N-FEMALE
 INTERFACE PER MIL-STD3-348A
 2 PLACES

Frequency Range: DC to 3.0 GHz
 VSWR max: 1.2:1
 Insertion Loss max.: 1.2 dB
 Phase Shift max.: 360° at 1.0 GHz

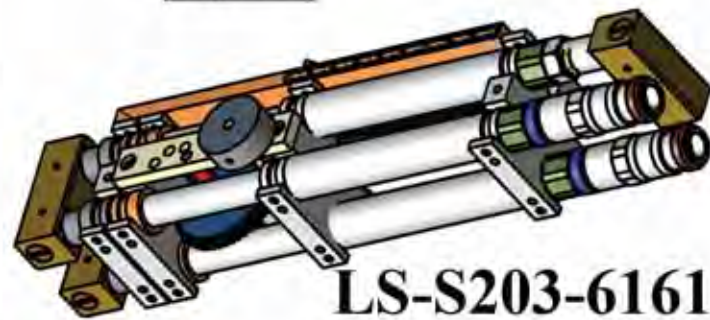

LS-S203-6161

Adjusting Phase.indd.2014

Trombone Line Phase Adjusters

Electrical	
Part Number	LS-0103-6161 LS-S203-6161
Impedance	50 Ohm
Frequency Range	DC - 3.0 GHz
Adjustment	180° at 1.0 GHz 360° at 1.0 GHz 540° at 3.0 GHz 1080° at 3.0 GHz
Return Loss	25 dB at 3.0 GHz
Insertion Loss max.	0.6 dB 1.2 dB
Dielectric Withstanding Voltage	2,500 volts rms at sea level
Insulation Resistance	5,000 MO minimum
RF Leakage	-(90-f(GHz)) dB
Mechanical	
Interface	MIL-STD-348A
Connector Durability	500 cycles, 12 cycles/minute
Material	
Fixture and Outer Conductor: Aluminum	AlMg4.5Mn and AlMgSiPb per DIN EN 573-3 (QQ-A-225/8)
Fixture and Outer Conductor: Stainless Steel	Corrosion resistant 1.4305 per DIN EN 10088-3 (ASTM-A-582-80)
Outer conductor: Brass	CuZn39Pb3 per DIN EN 12163/12164 (ASTM-B-16)
Center Contacts: Copper Beryllium	33-25 CuBE2Pb H per DIN 17666 (ASTM-B-196)
Insulators	PTFE: Fluorocarbon per ASTM-D-1710 Other Dielectrics: per inhouse specification
Finish	
Copper Beryllium	Centre Contacts shall be gold plated to a minimum thickness of .00005 inch (1.27 µm) in accordance with ASTM-B-488, Type III, Code C, Class 1.25
Stainless Steel	Passivated per ASTM-A-967
Brass	.00003 inch (0.75 µm) min. gold plating per ASTM-B-488, Type III Code C, Class 0.75, over nickel plating.
Aluminum	Conductive Parts shall have an iridited finish per MIL-C-5541
Environmental	
Tempertaure Range	Operating: -65°C to +115°C

Adjusting Phase.indd.2014



Adjusting Phase.indd.2014

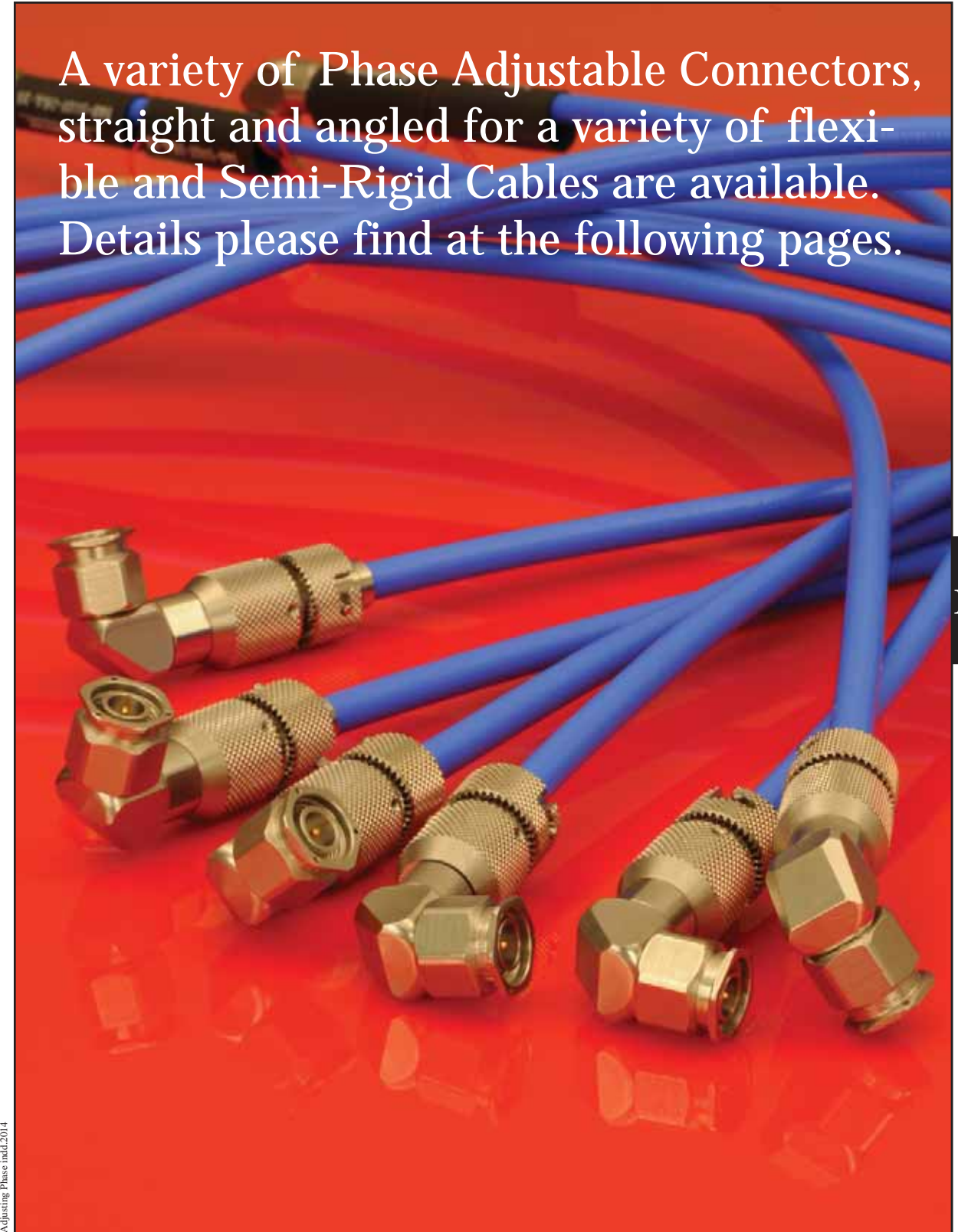

Adjusting Phase.indd.2014

Phase Matching

Cable Assemblies can be matched in Phase, Delay, and Amplitude. The most common matching is the Phase matching. It can be specified in electrical degrees at a specified frequency or in time delay. Three groups of candidates are of interest for phase matched cable assemblies:

- Flexible Cables, having one or more layers of braid as outer conductor
- Semi Rigid Cables, using copper or stainless steel for the outer conductor
- Semi Flexible Cables, easier formable by hand, using as outer conductor aluminum tubing (HandyForm II) or tinned copper braid (HandyForm I)

Phase Matched Cable Assemblies in Sets

Normally two specifications are being used for phase matched sets of cables assemblies:

- Matching to a Standard: The phase standard is usually a piece of hardware, a “Gold Standard”, it also could be an unchanging software standard; i.e. a specified electrical length at a certain frequency.
- Matching as a Set: Cable assemblies matched as a set means that the assemblies of the same set are matched to each other. The cables in one set may not match those of another set.



Adjusting Phase.indd.2014



Adjusting Phase.indd.2014

Phase matched Cable Assemblies: They are being used in many applications, the best known usage is in phase array antennas, where up to hundreds of assemblies have to be matched to a few degrees at the operating frequency. If it were possible to cut the cable assemblies mechanically 100% to length, this would not automatically mean that the assemblies had the same electrical length. This can easily be understood due to the following:

Frequency of Operation: The higher the operating frequency and the closer the required phase match, the more difficult the matching process will be, and the cost might be higher.

Length of Cable Assemblies: Short Cable Assemblies are usually easier to match and to test than longer assemblies. With longer assemblies there is already the problem that they need to be coiled for testing and this already results in phase changes, a wider match window is required.

Preconditioning: The cables of a phase-matched set need to be thermally stress relieved before phase matching. At Spectrum Elektrotechnik GmbH the cable is preconditioned by exposing it several times to temperatures of -54°C to +125°C, in some cases even between -71°C to +200°C. This will assure good phase tracking.

Temperature: Change in temperature will result in change of electrical length of the cable assembly, caused by the dielectric of the cable. Cables using solid extruded PTFE dielectric are generally strong mechanically but higher for insertion loss and show worst phase changes over temperature when compared to cables using high density dielectric. These latter cables are weaker mechanically but lower in insertion loss and have better phase versus temperature characteristics. The phase change with temperature may not be that critical if the complete set is exposed to the changing temperature, as the phase will shift equally in all of the assemblies of the set, assuming that assemblies are not formed in a bundle where the inner assemblies will see the temperature change much later than the outer assemblies. It will be most critical when assemblies of the same set, matched at the same temperature (e.g. ambient), but are subjected to different temperatures in the system.

Different Connectors at Assemblies in a set: There is no problem to use different connector styles in a set of matched cable assemblies; it may add additional cost though, as the matching process may get more complicated because of different connector lengths and dielectrics.

Cable Properties: A cable is not 100% mechanically homogeneous. The cable center contact has tolerances, as well as the dielectric and the outer conductor, causing slight differences in impedance and velocity of propagation. Manufacturing the cable without tolerance is not possible, unfortunately. For a cable the tolerance of the velocity of propagation is usually specified between +/-1% and +/-2%, resulting in different electrical lengths of cable assemblies in spite of having identical physical lengths. This will be noticeable especially with long cable assemblies or when using cable from different manufacturing lots.

Adjusting Phase.indd.2014

Connector Properties: The connectors used for terminating the Assemblies have tolerances as well, also in diameters and lengths of the center contact, dielectric and outer conductor. Although Spectrum Elektrotechnik GmbH is using the tightest tolerances of +/- 0.005 mm (0.0002 inches) at the important dimensions of the connectors; the connectors are not 100% identical.

Workmanship: Terminating the connectors to the assembly will add the next problem, as it is definitely not possible to mount the connectors 100% identical to each other onto the cables. There will always be minor mechanical differences in the gaps, and the solder joints, causing discrepancies in mechanical and electrical lengths. The cable assemblies will have slightly different VSWR, and this will cause some difference in phase as well. The tolerances will add up, and also the best possible workmanship will not guarantee for cable assemblies, identical electrically, especially at higher frequency applications.

Installation: Especially for matched sets with long cable assemblies phase changes can be expected during installation. Phase adjustable connectors or adapters can be used for phase correction after installation.

Bending: When the cable assemblies are being bent after the connectors have been terminated to the cable a phase change can be expected, due to the center conductor shifting versus the outer conductor. The mechanical and electrical length of the assembly will change, and the VSWR may change as well. This will result in phase change. For sets with long cable assemblies phase changes can be expected after the installation in a system. Phase change will depend also on the bend radii. If the cables are flexed, the number of cycles, and the similarity of the flexure cycles of the assemblies in the set have to be taken into consideration for phase tracking.

Phase matching using Phase Adjustable Connectors: In certain applications, especially when using Semi-Rigid Cable, the customer may want to make his own phase matched assemblies. Spectrum Elektrotechnik GmbH offers for those applications a variety of Phase Adjustable Connectors. The assembly procedures for terminating the cable with these Phase Adjustable connectors are similar to the procedure for regular connectors. The Phase Adjustable Connectors are available for frequencies from DC to 18.0 GHz, and DC to 26.0 GHz using SMA connectors, and designs operating from DC to 40.0 GHz, using 2.92 mm connectors. Designs for higher frequency applications may be available in the near future, using 2.4 mm and 1.85 mm connectors.

Phase matching using Phase Adjustable Adapters: Phase Adjustable Adapters operating up to 63.00 GHz are available as well. Standard cable assemblies may be matched by adding such a Phase Adjustable Adapter. These devices are available for frequencies from DC to 12.4 GHz, DC to 18.0 GHz and DC to 26.5 GHz, using SMA connectors, designs operating from DC to 40.0 GHz, using 2.92 mm connectors, units operating from DC to 50.0 GHz, using 2.4 mm connectors and devices operating from DC to 63.0 GHz, connectorized with 1.85 mm connectors.

Uncertainties: Vector Network Analyzers will be usually used in a temperature-controlled room. But still it has to be taken into consideration that test results taken even with the best equipment are subjected to tolerances.

Adjusting Phase.indd.2014

Factory Phase Adjustable Connectors
135° angles, used where a straight or
right angle does not fit.



Adjusting Phase.indd.2014

The company offers a wide variety of
Factory Phase Adjustable Connectors
for the frequency range up to 65 GHz.



Adjusting Phase.indd.2014

Spectrum Elektrotechnik GmbH has developed a number of techniques to phase match flexible assemblies and Semi-Rigid Cable Assemblies as well. From the outline the factory phase adjustable connectors do not show any difference, compared to any of Spectrum's standard connectors.

Internally these connectors are using well engineered components that are designed for:

Center Contact, Dielectric and Outer Conductor swopping for length changes, some of them to achieve length changes of a few hundreds of a millimeter only but maintaining perfectly 50 Ohms impedance. This system is of especial interest in programs where weight restrictions do exist, or where no parts are allowed that cannot be locked 100%, or where the assemblies are submitted to vibration.

A well kept secret for achieving Phase Adjustment is by swapping certain internal ferrules. After installation the parts are well secured within the connector that the units can undergo vibration without any problems. The design is also used where weight restrictions do exist. 50 Ohms impedance will be maintained 100%.

In several applications there are long flexible cable assemblies needed and Phase Matching among the assemblies is required as well. What happens to a 20 m assembly after having been pulled, even very carefully, through an airline body or its wings? The flexible cable assembly that has undergone factory phase matching, might not be phase matched any more. So after installation adjustment is necessary. A sizable number of phase adjustable connectors have been developed, even using a self locking mechanism.

Center Contact, and Outer Conductor swopping for length and diameter changes, and Dielectrics swopping with different Dielectric Constants. With this system changes of parts of a degree are possible, but always maintaining perfectly 50 Ohms impedance. These phase adjustable connectors are also of interest in programs where weight restrictions do exist, or where no parts are allowed that cannot be locked 100%, or where the assemblies are submitted to heavy vibration.

The systems only pay off for factory phase adjustments. The reason is borne in the high number of piece parts needed. Using the system by the customer, the necessary number of piece parts, center contacts, dielectrics and outer conductors would need to be in stock at customer site for phase matching only a few assemblies, and this would make it obviously too expensive. As Spectrum is phase matching assemblies on a daily basis, all necessary piece parts in all the different lengths and diameters are in stock, resulting in reasonable priced Phase Matched Cable Assemblies.

The outline drawings to the right show a number of Phase Adjustable Connectors that have been developed and delivered to several customers and their programs. For new applications Spectrum Elektrotechnik GmbH is constantly designing additional Phase Adjustable Connectors and new Techniques. Please do not hesitate to contact the Company, if a standard product does not fit your needs.

Adjusting Phase.indd.2014

The Factory Phase Adjustable Connectors look like regular connectors. They are only sold already terminated at Phase Matched Cable Assemblies, adjusted to customer specification.

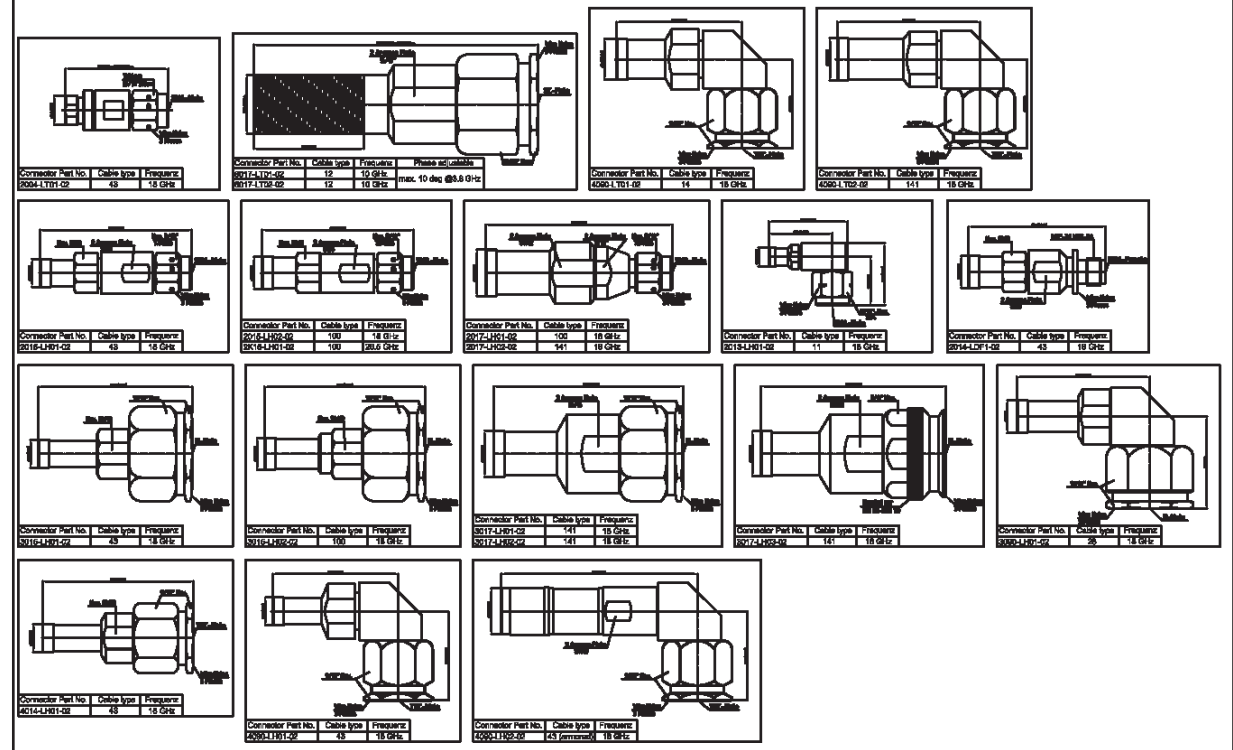

The company uses several systems to achieve the necessary phase adjustment. The pictures above show some example connectors. In general phase adjustment can be made at almost any connector style and for frequencies up to 65 GHz. Every system guarantess that the impedance is always maintained to 50 Ohms.

System 1:
Swopping internal parts, such as Center- & Outer Conductors, & Dielectrics. From the outside the unit looks like a normal Connector.

System 2:
Swopping certain internal ferrules to change the length of the connector. Also in this case the Phase Adjustment cannot be seen from the outside.

System 3: Phase Adjustment by swopping internal parts of the connectors, exchanging also dielectrics with different dielectric constants

After the company has adjusted the connector and sealed no further or additional phase adjustment can be made.

Adjusting Phase.indd.2014

In many cases Assemblies using Multiport Connectors need to be phase matched. A variety of Inserts are available to phase match any Multiport at the factory.

Connector Part No.	Cable type	Frequenz
TQ11-LH01-02	T1	18 GHz
TQ43-LH01-02	43	18 GHz
TQ11-LHF1-02	T1	18 GHz
TQ43-LHF1-02	43	18 GHz
TQ10-21E1-PH	100	18 GHz
TQ25-LH01-02	SFT 205	18 GHz
TQ10-21E1-PH	100	18 GHz
TQ25-LHF1-02	SFT 205	18 GHz
TQ11-LH01-02	102	18 GHz
TQ11-LHF1-02	102	18 GHz
TX11-LH01-02	11	40 GHz
TX11-LHF1-02	11	40 GHz
RQ11-LH01-02	11	18 GHz
RQ11-LHF1-02	11	18 GHz
RQ43-LH01-02	43	18 GHz
RQ43-LHF1-02	43	18 GHz



Adjusting Phase.indd.2014

The Customer Phase Adjustable Connectors look different, compared to the regular connectors. After they are terminated to the assemblies and the company has set the cable assemblies to the specified phase the customer can adjust the phase then at his convenience and at any time. Used is this often at long cable assemblies. After the customer puts the assemblies in place, e.g. from the wings of an airplane to the cockpit he then can adjust the assemblies again to his needs.

Connector Part No.	Cable type	Frequenz
Q125-LG1-02	125	18 GHz
Q205-LG1-02	205	18 GHz
Q305-LG1-02	305	18 GHz
Q405-LG1-02	405	18 GHz
Q505-LG1-02	505	18 GHz
Q605-LG1-02	605	18 GHz
Q705-LG1-02	705	18 GHz
Q805-LG1-02	805	18 GHz
Q905-LG1-02	905	18 GHz
Q1005-LG1-02	1005	18 GHz
Q1105-LG1-02	1105	18 GHz
Q1205-LG1-02	1205	18 GHz
Q1305-LG1-02	1305	18 GHz
Q1405-LG1-02	1405	18 GHz
Q1505-LG1-02	1505	18 GHz
Q1605-LG1-02	1605	18 GHz
Q1705-LG1-02	1705	18 GHz
Q1805-LG1-02	1805	18 GHz
Q1905-LG1-02	1905	18 GHz
Q2005-LG1-02	2005	18 GHz
Q2105-LG1-02	2105	18 GHz
Q2205-LG1-02	2205	18 GHz
Q2305-LG1-02	2305	18 GHz
Q2405-LG1-02	2405	18 GHz
Q2505-LG1-02	2505	18 GHz
Q2605-LG1-02	2605	18 GHz
Q2705-LG1-02	2705	18 GHz
Q2805-LG1-02	2805	18 GHz
Q2905-LG1-02	2905	18 GHz
Q3005-LG1-02	3005	18 GHz
Q3105-LG1-02	3105	18 GHz
Q3205-LG1-02	3205	18 GHz
Q3305-LG1-02	3305	18 GHz
Q3405-LG1-02	3405	18 GHz
Q3505-LG1-02	3505	18 GHz
Q3605-LG1-02	3605	18 GHz
Q3705-LG1-02	3705	18 GHz
Q3805-LG1-02	3805	18 GHz
Q3905-LG1-02	3905	18 GHz
Q4005-LG1-02	4005	18 GHz
Q4105-LG1-02	4105	18 GHz
Q4205-LG1-02	4205	18 GHz
Q4305-LG1-02	4305	18 GHz
Q4405-LG1-02	4405	18 GHz
Q4505-LG1-02	4505	18 GHz
Q4605-LG1-02	4605	18 GHz
Q4705-LG1-02	4705	18 GHz
Q4805-LG1-02	4805	18 GHz
Q4905-LG1-02	4905	18 GHz
Q5005-LG1-02	5005	18 GHz
Q5105-LG1-02	5105	18 GHz
Q5205-LG1-02	5205	18 GHz
Q5305-LG1-02	5305	18 GHz
Q5405-LG1-02	5405	18 GHz
Q5505-LG1-02	5505	18 GHz
Q5605-LG1-02	5605	18 GHz
Q5705-LG1-02	5705	18 GHz
Q5805-LG1-02	5805	18 GHz
Q5905-LG1-02	5905	18 GHz
Q6005-LG1-02	6005	18 GHz
Q6105-LG1-02	6105	18 GHz
Q6205-LG1-02	6205	18 GHz
Q6305-LG1-02	6305	18 GHz
Q6405-LG1-02	6405	18 GHz
Q6505-LG1-02	6505	18 GHz
Q6605-LG1-02	6605	18 GHz
Q6705-LG1-02	6705	18 GHz
Q6805-LG1-02	6805	18 GHz
Q6905-LG1-02	6905	18 GHz
Q7005-LG1-02	7005	18 GHz
Q7105-LG1-02	7105	18 GHz
Q7205-LG1-02	7205	18 GHz
Q7305-LG1-02	7305	18 GHz
Q7405-LG1-02	7405	18 GHz
Q7505-LG1-02	7505	18 GHz
Q7605-LG1-02	7605	18 GHz
Q7705-LG1-02	7705	18 GHz
Q7805-LG1-02	7805	18 GHz
Q7905-LG1-02	7905	18 GHz
Q8005-LG1-02	8005	18 GHz
Q8105-LG1-02	8105	18 GHz
Q8205-LG1-02	8205	18 GHz
Q8305-LG1-02	8305	18 GHz
Q8405-LG1-02	8405	18 GHz
Q8505-LG1-02	8505	18 GHz
Q8605-LG1-02	8605	18 GHz
Q8705-LG1-02	8705	18 GHz
Q8805-LG1-02	8805	18 GHz
Q8905-LG1-02	8905	18 GHz
Q9005-LG1-02	9005	18 GHz
Q9105-LG1-02	9105	18 GHz
Q9205-LG1-02	9205	18 GHz
Q9305-LG1-02	9305	18 GHz
Q9405-LG1-02	9405	18 GHz
Q9505-LG1-02	9505	18 GHz
Q9605-LG1-02	9605	18 GHz
Q9705-LG1-02	9705	18 GHz
Q9805-LG1-02	9805	18 GHz
Q9905-LG1-02	9905	18 GHz
Q10005-LG1-02	10005	18 GHz



Adjusting Phase.indd.2014

Phase Adjustable Connectors of Series SMA for Semi-Rigid Cable Assemblies DC to 18.0 and to 26.0 GHz

SMA Adjustable coaxial Phase Shifters Models LS-0141-02, LS-V141-02, LS-0085-02 and LS-0086-02 LS-R141-02 (metrical thread at the coupling nut)	
Cable Type	0.085" & 0.0141" Semi Rigid
Frequency Range	DC - 26.0 GHz
Adjustment	Max. 127° at 26.0 GHz
Impedance	50 Ohms
Max. VSWR	1.05 + .008f(GHz)
Insertion Loss	(.05 SQT(f(GHz)))dB
R.F. Leakage	-90 dBC
Temperature Range	-65°C to +115°C

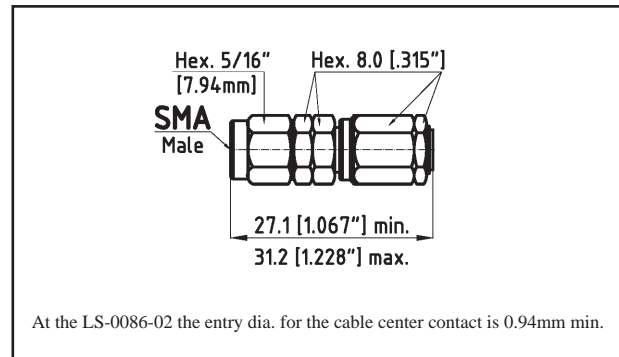

The Models LS-0141-02 and LS-0085-02 are adjustable coaxial Phase Shifters, covering the full frequency range of DC to 26.0 GHz with an adjustment capability of max. 127° at 26.0 GHz. The Phase Adjustable Connectors may practically eliminate the need to trim cables to predetermined lengths, in order to achieve the exact phase requirements of a microwave network. Cables only need to be trimmed to the approximate electrical length. The Phase Shifter then allows to make the necessary adjustment between the other components in the system. As a result of the small size and light weight, these Phase Shifters can be used in applications with space limitations, such as airborne and satellite equipment.

The Phase Adjustable Connector LS-0085-S001 has been designed for panel mount usage where the phase adjusted assembly is inside a box. Application might be the fine adjustment of a delay line.

Part Number	Cable Type	Frequency Range	VSWR max.	Insertion Loss max.	Phase Shift min.	No. of Turns	Nom. Phase Shift Deg./GHz/Turnh	Time Delay (psec.) min. max.	Weight max.
LS-0141-02	0.141" Semi-Rigid	DC - 26.0 GHz	1.25 : 1	0.26 dB	127° at 26.0 GHz	9	0.55	72.2 87.6	9 g
LS-0085-02 LS-0086-02 ¹⁾	0.085" Semi-Rigid								9 g
LS-0085-S001	0.085" Semi-Rigid	DC - 18.0 GHz	1.12 : 1	0.25 dB	50° at 18.0 GHz	5	0.55	85.3 93.7	9 g
LS-R141-02 ^{A)}	0.141" Semi-Rigid	DC - 18.0 GHz	1.12 : 1	0.25 dB	50° at 18.0 GHz	5	0.55	85.3 93.7	9 g

A) The Phase Adjustable Connector LS-R141-02 is not for standard use, as it has metric thread in the coupling nut

SMA Adjustable coaxial Phase Shifter Model LS-0085-S001	
Cable Type	0.085" Semi Rigid
Frequency Range	DC - 18.0 GHz
Adjustment	Max. 50° at 18.0 GHz
Impedance	50 Ohms
Max. VSWR	1.12:1 at 18.0 GHz
Insertion Loss	0.25 dB at 18.0 GHz
R.F. Leakage	-90 dBC
Temperature Range	-65°C to +115°C

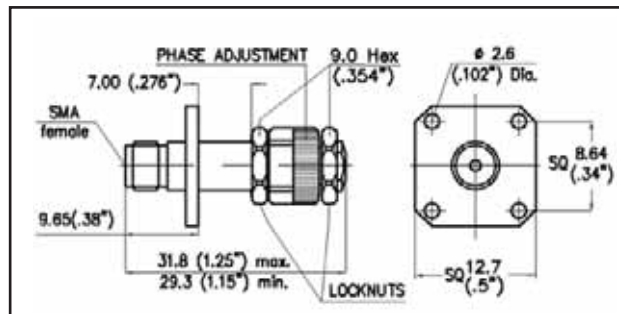

Adjusting Phase.indd.2014

Phase Adjustable SMA Connectors for Flexible Cables

Adjustable coaxial Phase Shifters Models LS-0200-02, LS-1801-02	
Frequency Range	DC - 26.0 GHz
Adjustment	max. 155°@ 26.0 GHz
Impedance	50 Ohms
Max. VSWR	1.25:1 @ 26.0 GHz
Insertion Loss	(.05 SQT(f(GHz))) dB
R.F. Leakage	-90 dBC
Temperature Range	-65°C to +115°C

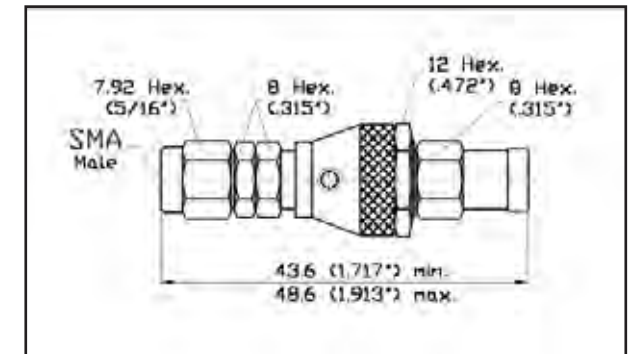

Part Number	Cable Type	Frequency Range	VSWR max.	Insertion Loss max.	Phase Shift min.	No. of Turns	Nom. Phase Shift Deg./GHz/Turn	Time Delay (psec.) min. max.	Weight max.
LS-0200-02 LS-1801-02	100	DC - 26.0 GHz	1.25:1	0.26 dB	155° at 26.5 GHz	10	0.60	80.1 96.8	t.b.d.

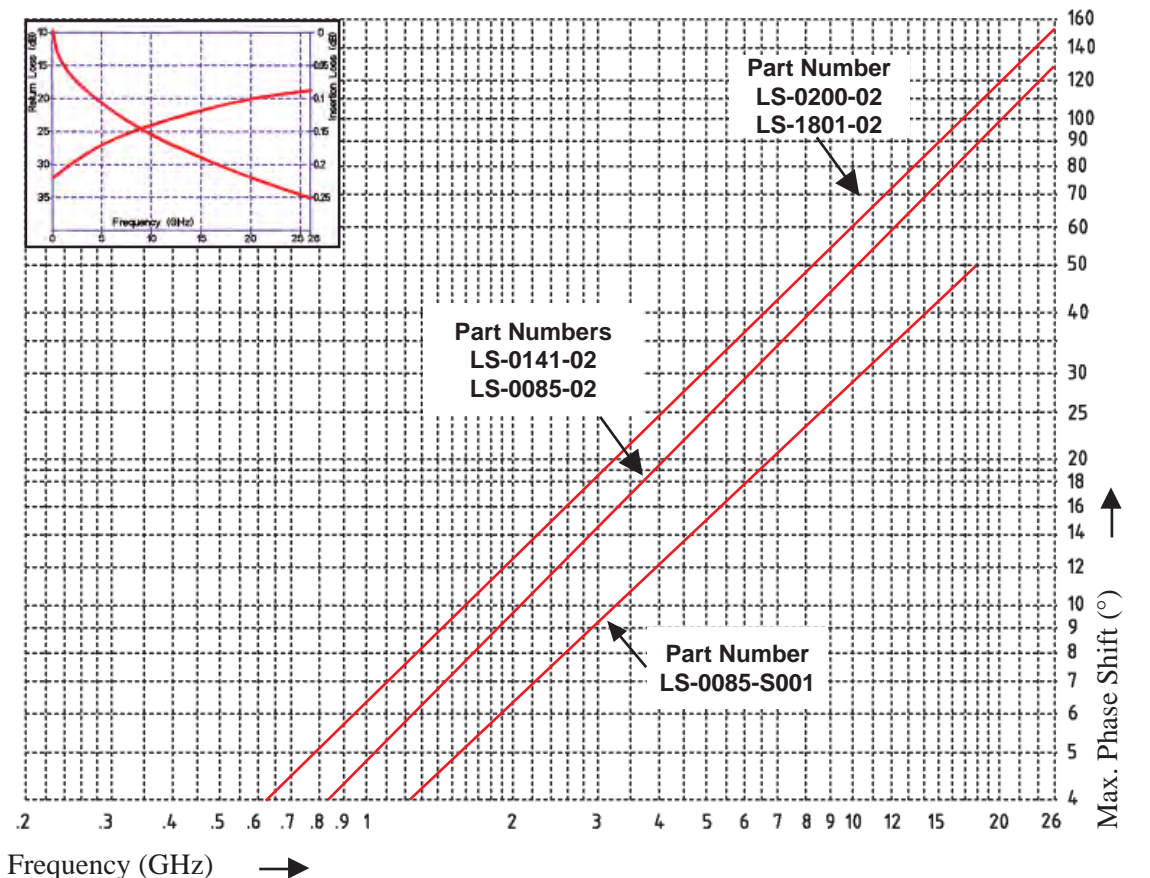

Adjusting Phase.indd.2014

Phase Adjustable Connectors of Series **TNC** for flexible Cable Assemblies DC to 18.0

TNC Coaxial Phase Adjuster Model 4015-LC01-02	
Cable Type	100 Flexible
Frequency Range	DC - 18.0 GHz
Adjustment	Max. 100° at 18.0 GHz
Impedance	50 Ohms
Max. VSWR	1.05 + .008f(GHz)
Insertion Loss	(.05 SQT(f(GHz)))dB
R.F. Leakage	-90 dBC
Temperature Range	-65°C to +115°C

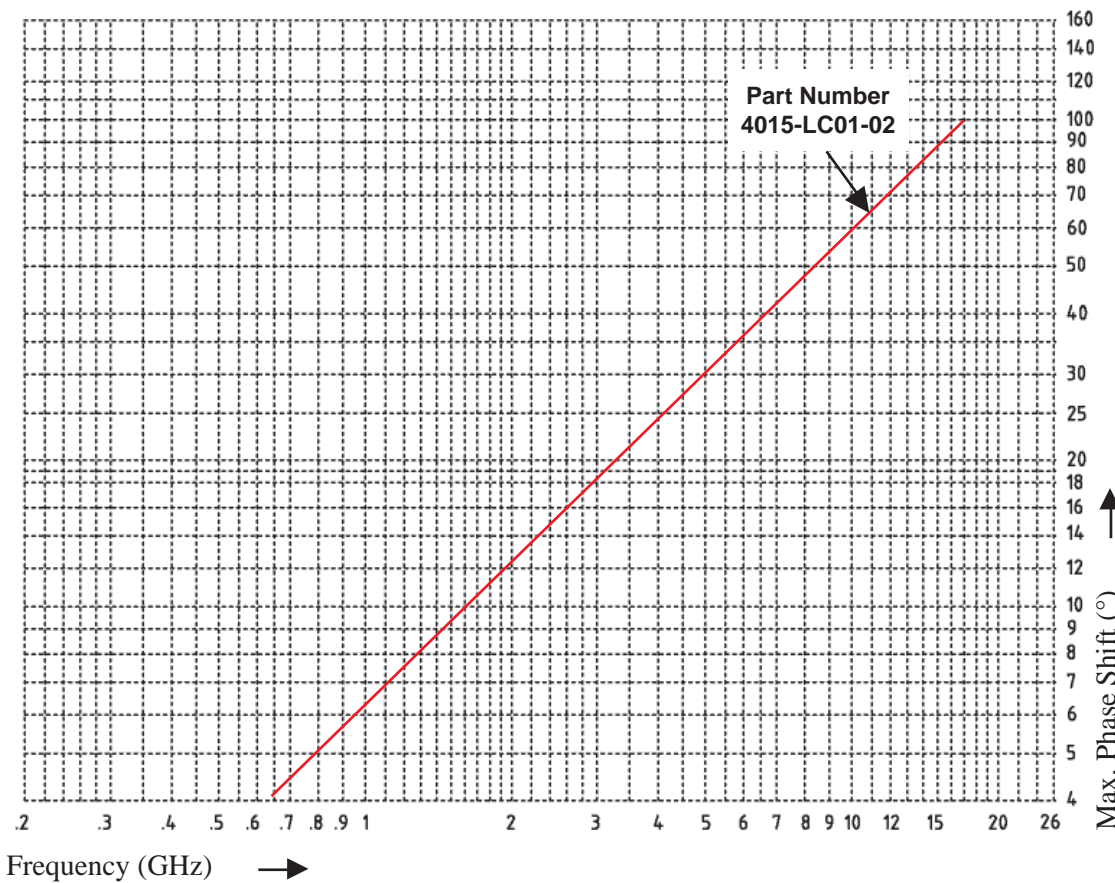
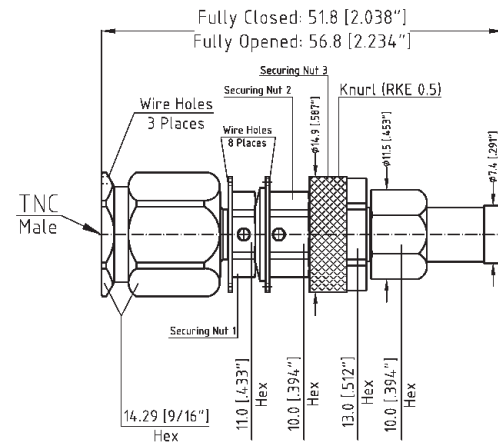

Adjusting Phase.indd.2014

YOU NEED SOMETHING DIFFERENT?

SPECTRUM DESIGNS, MANUFACTURES, ASSEMBLES AND TESTS ALMOST EVERYTHING **IN-HOUSE, RESULTING IN:**

- **SHORT WAYS**
- **FAST RESPONSE TIME**
- **SHORT DELIVERY**
- **HIGHEST QUALITY**

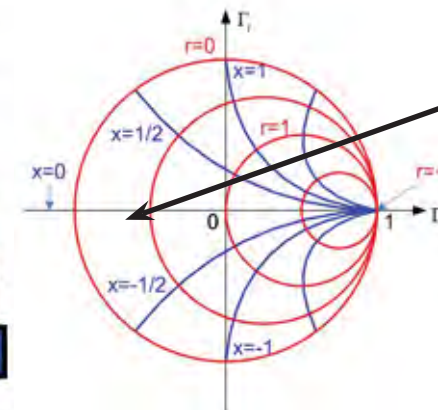

Adjusting Phase.indd.2014

Phase Adjustable Connectors of Series **2.92 mm** and **SMP** for Semi-Rigid Cable Assemblies operating from DC to 18.0 GHz and DC to 40.0 GHz, for easy use at customer site.

2.92 mm Adjustable coaxial Phase Shifters Model 15L3-1001-02	
Cable Type	0.085" Semi Rigid
Connector Type	2.92 mm
Frequency Range	DC - 40.0 GHz
Adjustment	200° min. at 40.0 GHz
Impedance	50 Ohms
Max. VSWR	1.4 max at 40.0 GHz
Insertion Loss	0.2 dB max. at 40 GHz
R.F. Leakage	-90 dBC
Temperature Range	-65°C to +115°C

SMP Adjustable coaxial Phase Shifters Model 1102-65LS-04	
Cable Type	0.047" Semi Rigid
Connector Type	SMP
Frequency Range	DC - 26.0 GHz
Adjustment	45° min at 26.0 GHz
Impedance	50 Ohms
Max. VSWR	1.15 max, @ 26 GHz
Insertion Loss	0.25 max. at 26 GHz
R.F. Leakage	not applicable
Temperature Range	-65°C to +115°C

Part Number	Cable Type	Frequency Range	VSWR max.	Insertion Loss max.	Phase Shift min.	No. of Turns	Nom. Phase Shift Deg./GHz/Turnh	Time Delay (psec.) min. max.	Weight max.
15L3-1001-02	0.085" Semi-Rigid	DC-40.0 GHz	1.2:1 max.	0.4 dB max.	200° at 40 GHz	9	0.55	110 125	35
1102-65LS-04	0.047" Semi-Rigid	DC - 18.0 GHz	1.15 : 1	0.21 dB	30° at 18.0 GHz	5.5	0.3	57 62	2.6 g



Adjusting Phase.indd.2014

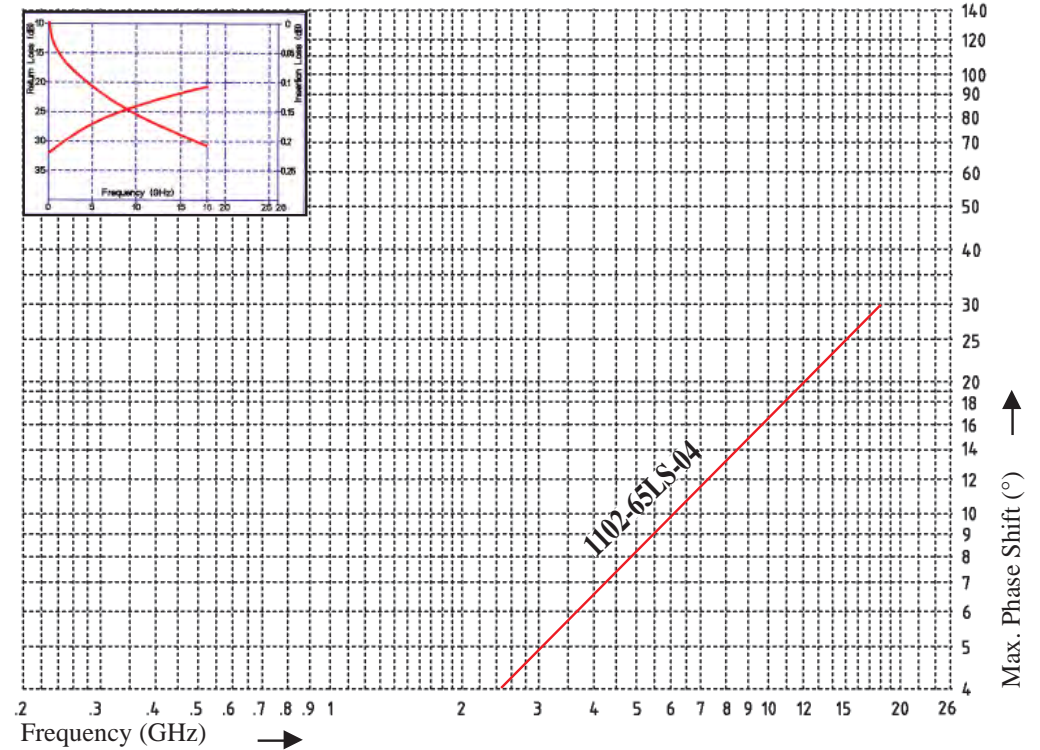

1102-65LS-04

Phase Matching Long Flexible Cable Assemblies

There always will be a problem with long flexible phase matched Cable Assemblies. When they are routed in the system to their final position, e.g. through the wings or in the body of an airplane, they will be bent and maybe slightly stretched. The perfectly factory matched assemblies may not be phase matched anymore after the installation. Spectrum Elektrotechnik GmbH developed phase adjustable connectors, being adjustable over a wide range in order to adjust the Cable Assemblies after installation. These phase adjustable connectors are self locking.

Specification of the Phase Adjustable Self Locking Connectors

Frequency Range	Nom. Phase Shift Deg/GHz/Locking Tooth	No. of Turns	Phase Shift min.	Nom. Phase Shift Deg/GHz/Turn
DC-18.0 GHz	0.015	10	100° @ 18 GHz	0.6
DC-18.0 GHz	0.015	22.5	240° @ 18 GHz	0.6
DC-18.0 GHz	0.015	26	280° @ 18 GHz	0.6

The details about the most used Phase Adjustable Self Locking Connectors by connector code are shown in this table. Please note: The table is not complete.

Connector Code	Connector	Phase Adjustment		Frequency Range
11L	SMA male straight	few degrees	fixed	DC to 4 GHz
11A		100° min. @ 18 GHz	continuous	DC to 18 GHz
11C		240° min. @ 18 GHz		
15L	SMA Right Angle male	few degrees	fixed	DC to 4 GHz
15A		100° min. @ 18 GHz	continuous	DC to 18 GHz
15C		240° min. @ 18 GHz		
31L	TNC male straight	few degrees	fixed	DC to 4 GHz
31A		100° min. @ 18 GHz	continuous	DC to 18 GHz
31C		240° min. @ 18 GHz		
35L	TNC Right Angle male	few degrees	fixed	DC to 4 GHz
35A		100° min. @ 18 GHz	continuous	DC to 18 GHz
35C		240° min. @ 18 GHz		
51L	N male straight	few degrees	fixed	DC to 4 GHz
51A		100° min. @ 18 GHz	continuous	DC to 18 GHz
51C		240° min. @ 18 GHz		
55L	N Right Angle male	few degrees	fixed	DC to 4 GHz
55A		100° min. @ 18 GHz	continuous	DC to 18 GHz
55C		240° min. @ 18 GHz		
80L	SC male straight	few degrees	fixed	DC to 8.5 GHz
80A		55° min. @ 10 GHz	continuous	DC to 8.5 GHz
KMA	2.92 mm male straight	220° min. @ 40 GHz	continuous	DC to 40 GHz

Adjusting Phase.indd.2014

Phase Adjustable Self Locking Connectors are available for a variety of Spectrum's Cables, such as Types 11, 43, 100, 141, 143



Phase Adjustable Self Locking Connector Styles available are: SMA, TNC and N, males and females, straight and right angles. Spectrum Elektrotechnik GmbH will be happy to manufacture any other Phase Adjustable Connectors for your program.

Adjusting Phase.indd.2014

In addition to the Summary of Factory Installed Phase Adjustable Connectors, as seen on page C7, to the left you will find the dimensions of the Right Angle Phase Adjustable Connectors of Type TNC male, which have been used in several major programs. As you can see, the dimensions of these Phase Adjustable Connectors have been kept to a minimum, and therefore can easily be used to replace the standard non-adjustable connectors.

The connectors are available with 3 different adjustments, 100° min., 240° min. and 280° min @ 18 GHz.

Please do not hesitate to ask for data sheets on the other connectors.

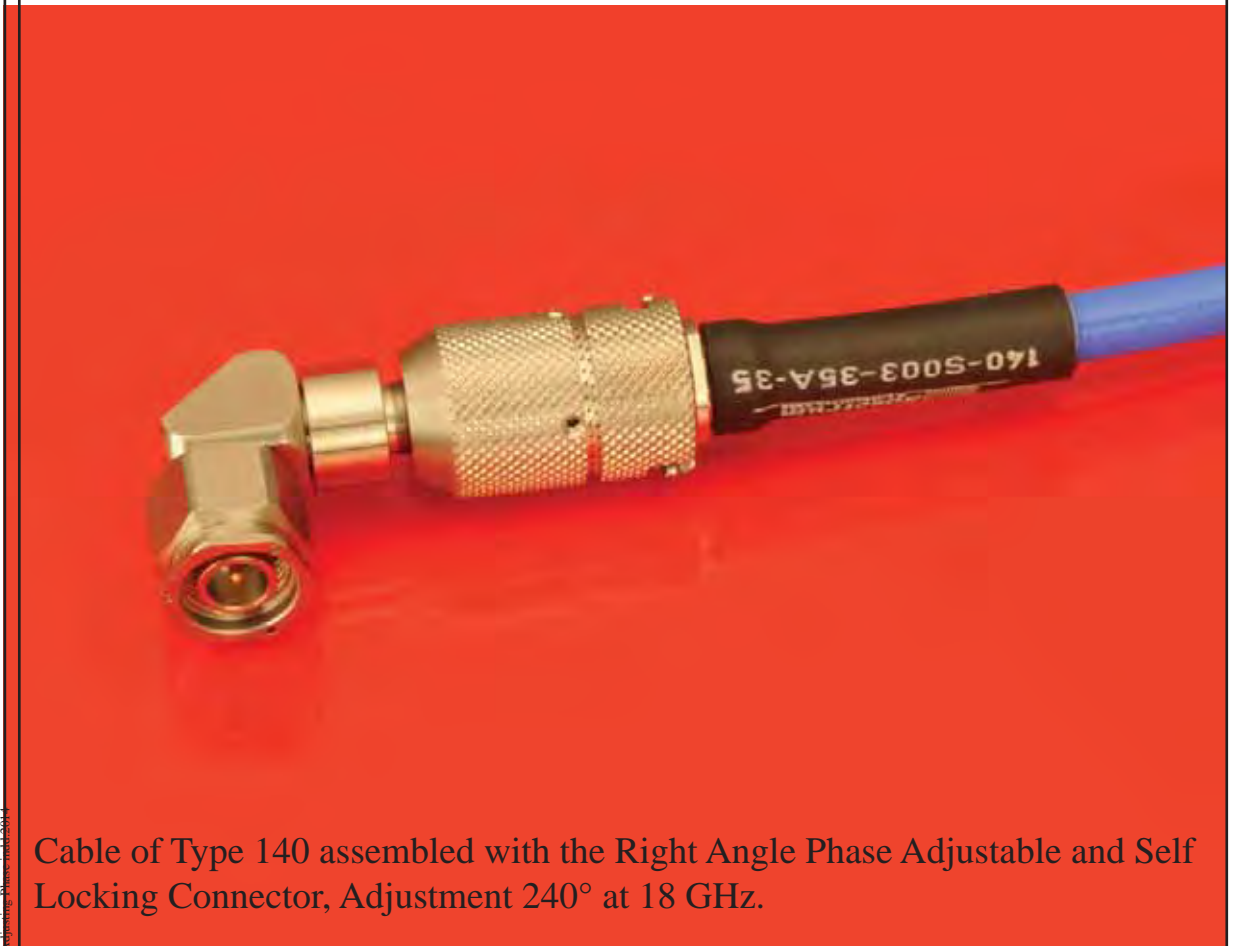

Cable of Type 140 assembled with the Right Angle Phase Adjustable and Self Locking Connector, Adjustment 240° at 18 GHz.

TNCm Right Angle Phase Adjustable and Self Locking Connector, Adjustment: 100° min. @18 GHz

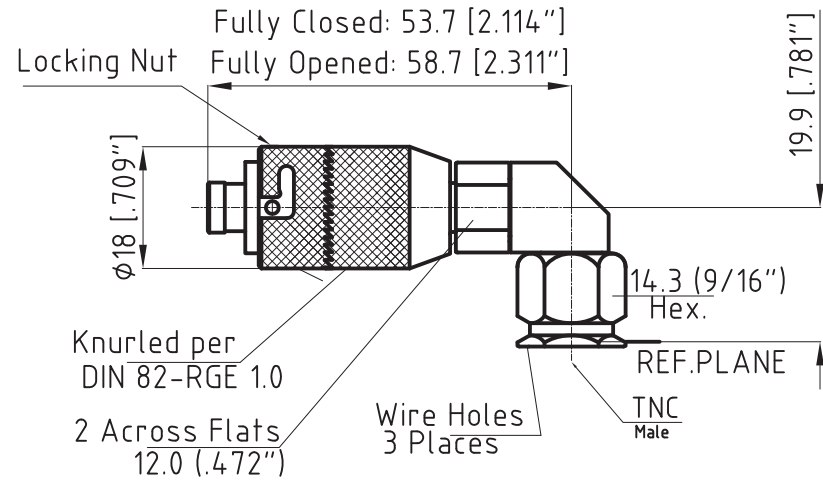

TNCm Right Angle Phase Adjustable and Self Locking Connector, Adjustment: 240° min. @18 GHz

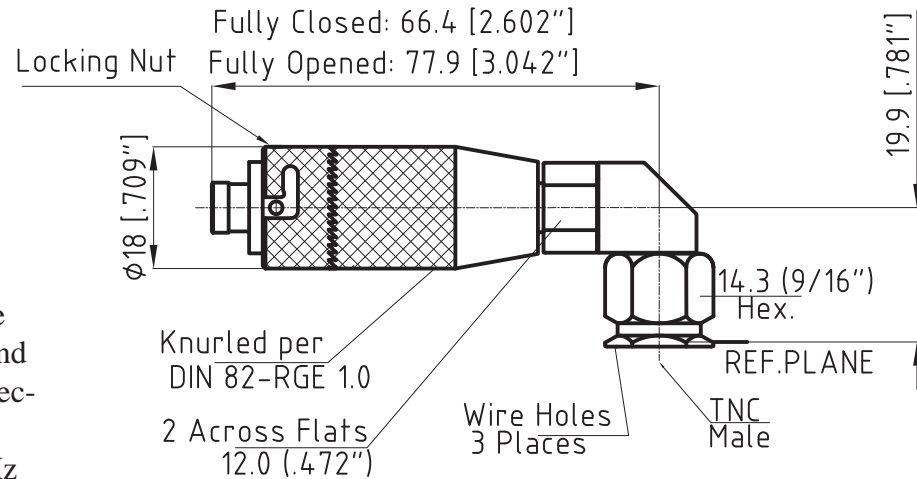

TNCm Right Angle Phase Adjustable and Self Locking Connector, Adjustment: 280° min. @18 GHz

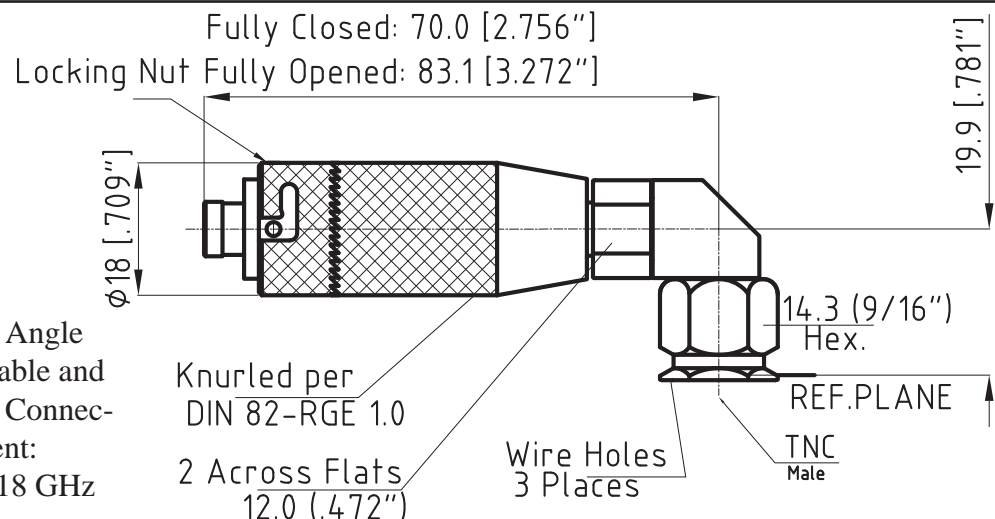

Phase Adjustable Self Locking Connectors, connector styles:

Phase Adjustable Self Locking Connectors have been developed for several Connector Series, as shown to the right and for several of our cables.

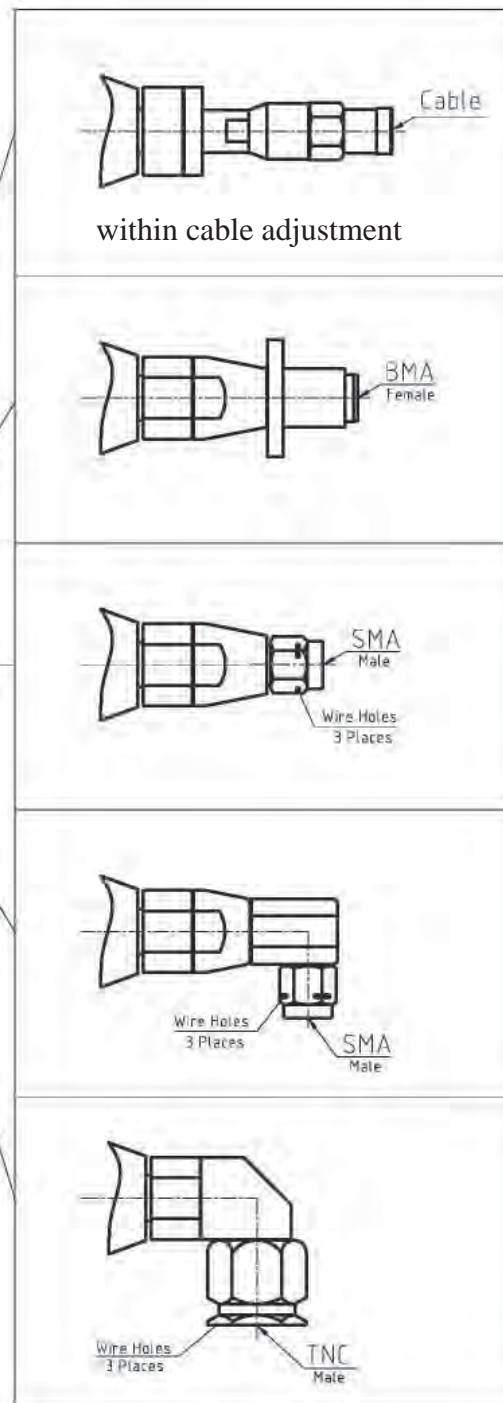
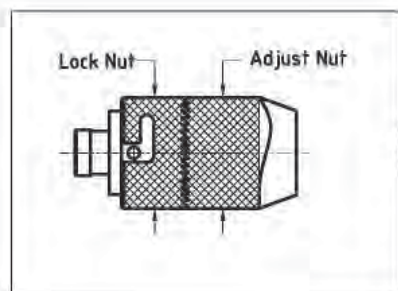

The connectors to the right do not show the complete status of series and sexes available. The family of Phase Adjustable Self Locking Connectors became very popular and therefore is constantly increasing.

Adjusting Phase.indd.2014

Phase Setting Procedure for the Phase Adjustable Self Locking Connectors

- 1) The phase of a set of cable assemblies will be set at the factory to customer specification before delivery.
- 2) After installing and routing the cables in the system, pulling the cables through the wings or the body of an airplane, the phase might have been changed.
- 3) Please follow the steps A) to C) below to adjust the Phase. The Phase Adjustable Connector is using an Adjust Nut for the Phase Adjustment and a Lock Nut for safe locking.

A) Unlock the Adjust Nut by pulling the Lock Nut back and lock it safely, as shown.

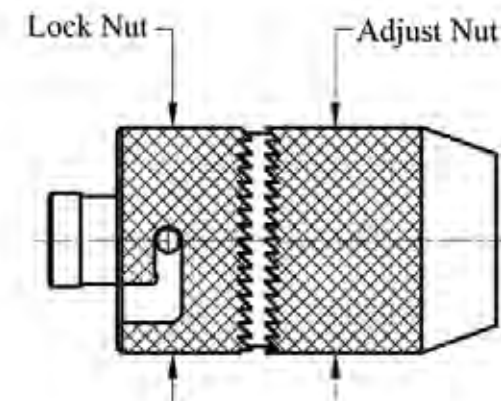

B) Adjust the phase to your needs by rotating the Adjust Nut in the direction required.

C) When phase has been set, release Lock Nut to keep the Adjust Nut from moving, and to set the phase safely.

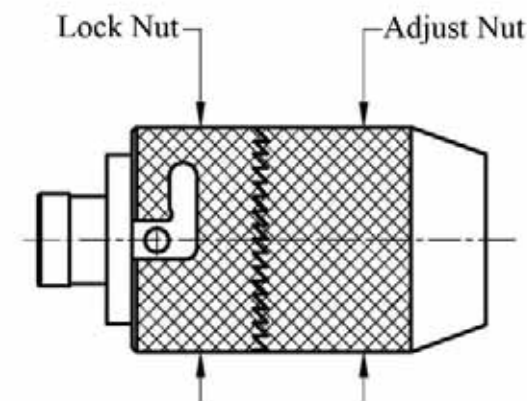

Adjusting Phase.indd.2014

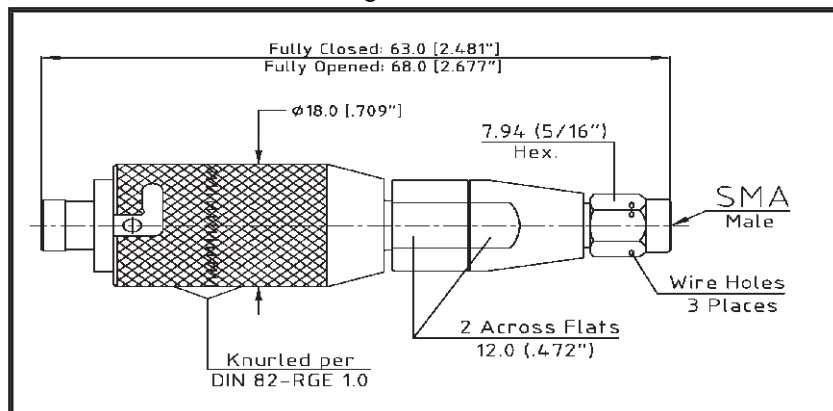

P/N 2015-LC01-02

Phase Adjustable Self Locking Cable Connectors of Type **SMA**, straight for Cable Type 100

Phase Adjustment:
100° @ 18 GHz

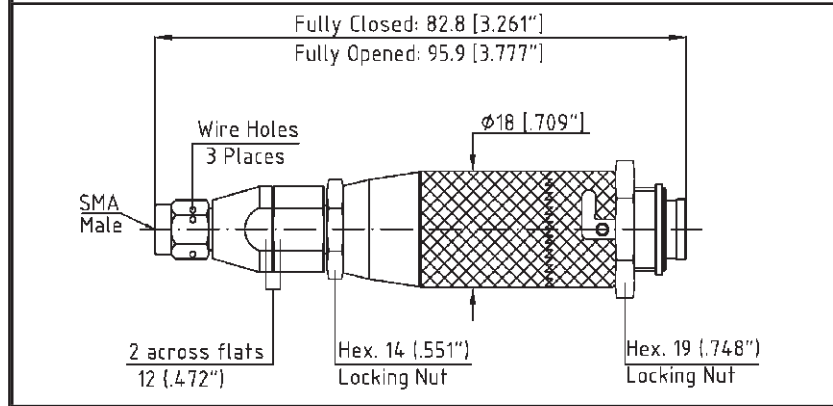

P/N 2015-LC03-02

Phase Adjustable Self Locking Cable Connectors of Type **SMA** straight for Cable Type 100

Phase Adjustment:
280° @ 18 GHz

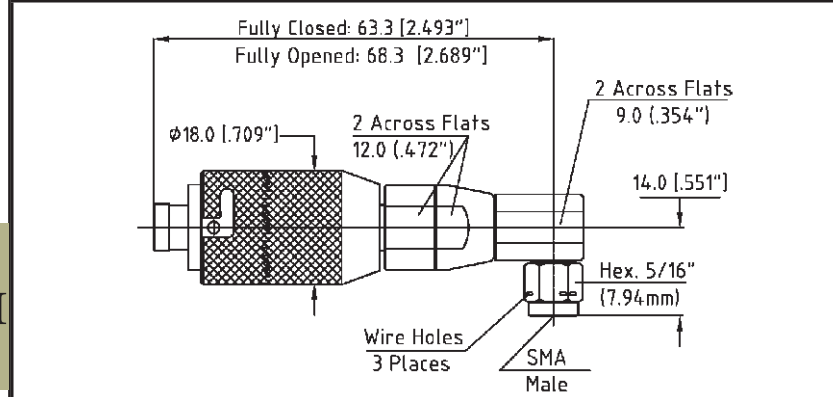

P/N 2090-LC01-02

Phase Adjustable Self Locking Cable Connectors of Type **SMA** right angle for Cable Type 100

Phase Adjustment:
100° @ 18 GHz

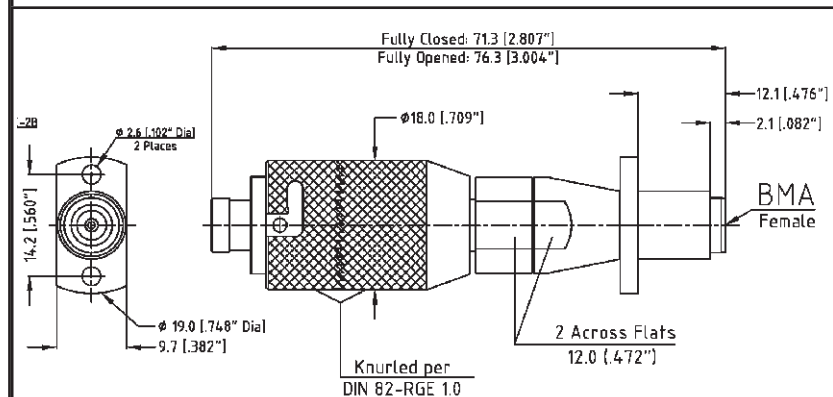

P/N 2315-LC01-02

Phase Adjustable Self Locking Cable Connectors of Type **BMA** straight for Cable Type 100

Phase Adjustment:
100° @ 18 GHz

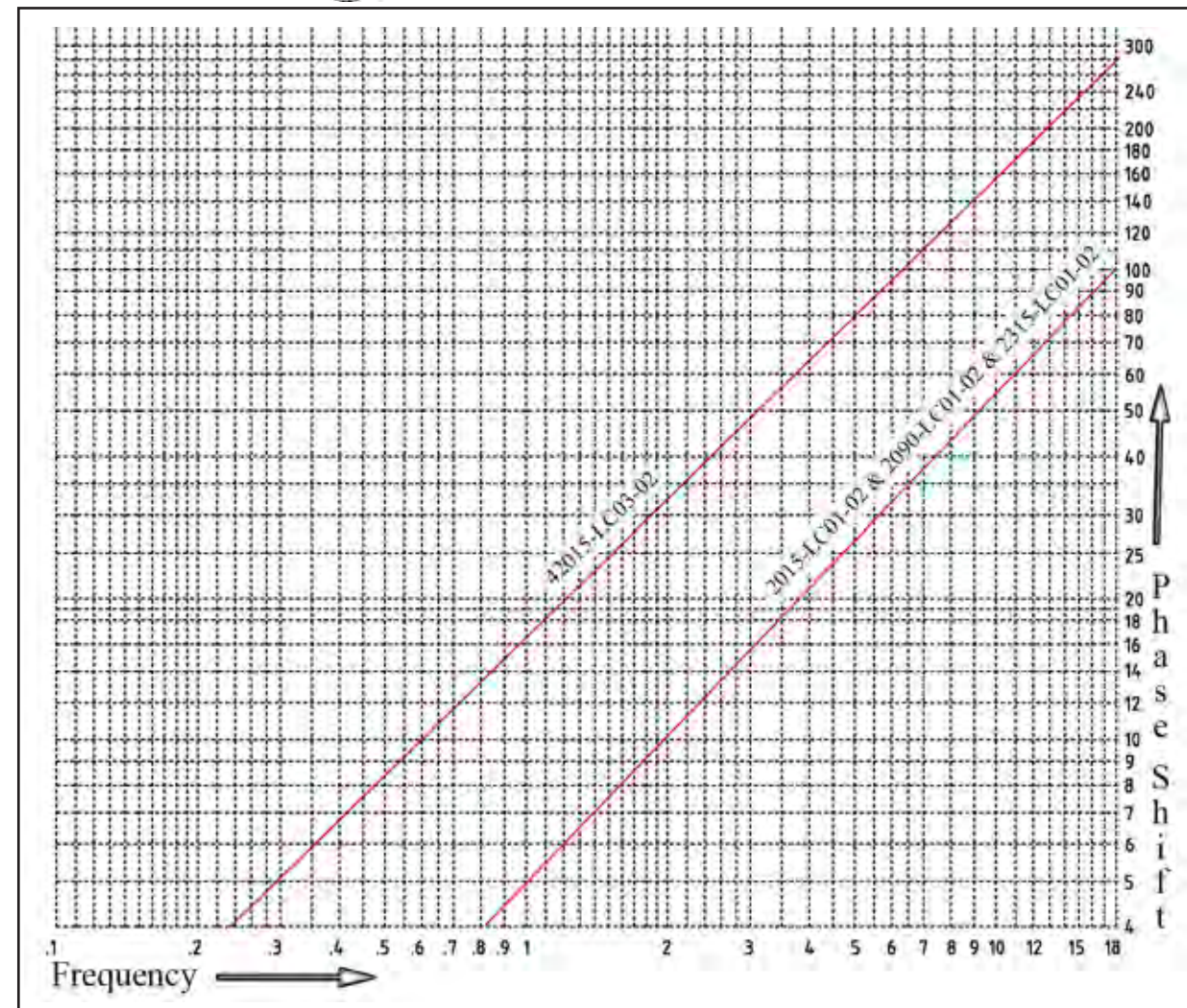

If you need the phase adjustable connector for another cable?

- Please talk to us, maybe there is only a minor change at an existing design needed
- Is your cable Flexible Cable, or Semi Rigid?

If you need a phase adjustable connector for another connector series?

- Our engineering team will be happy to listen to the details of your need and submit a proposal
- Engineering and Design is our business

SMA and BMA Coaxial Phase Adjusters Models as per table to the left	
Cable Type	100, flexible
Frequency Range	DC - 18.0 GHz
Adjustment	see table to the left
Impedance	50 Ohms
Max. VSWR	1.05 + .008f(GHz)
Insertion Loss	(.1 SQT(f(GHz)))dB
R.F. Leakage	-80 dBC
Temperature Range	-65°C to +115°C

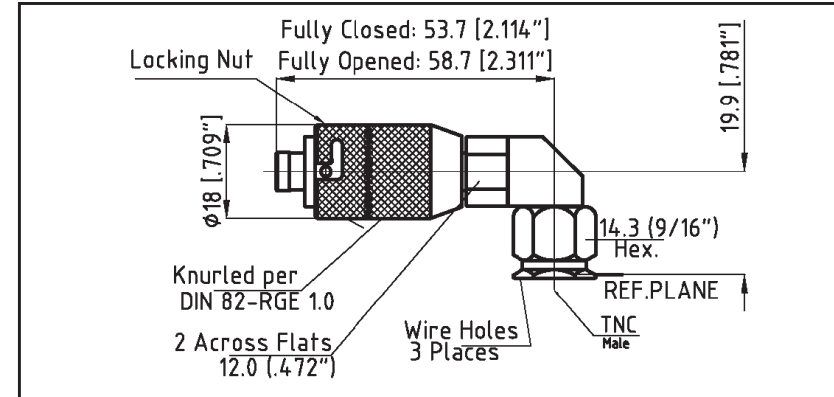
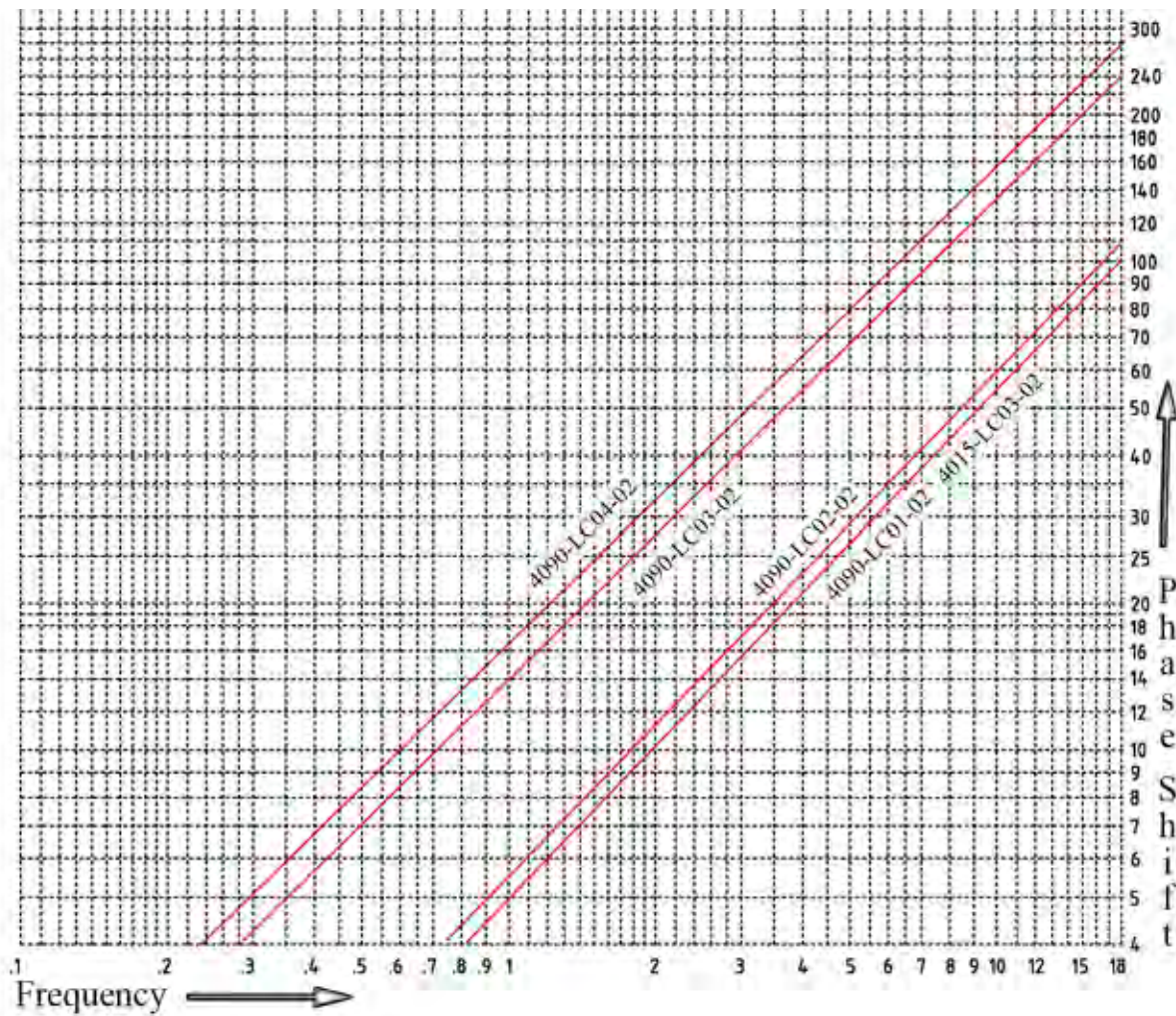

P/N 4090-LC01-02
P/N 4090-LC02-02

Phase Adjustable Self Locking Cable Connectors of Type TNC right angle Cable Type 140
 Phase adjustment: 100° & 108° max.

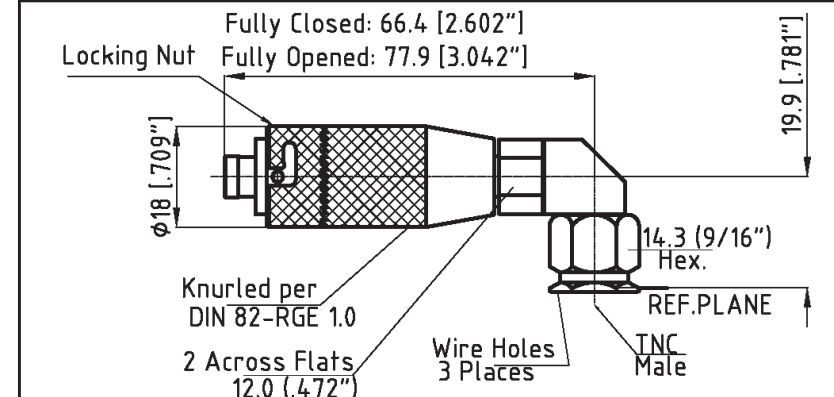

P/N 4090-LC03-02

Phase Adjustable Self Locking Cable Connectors of Type TNC right angle
 Cable Type 140
 Phase adjustment: 240° max.

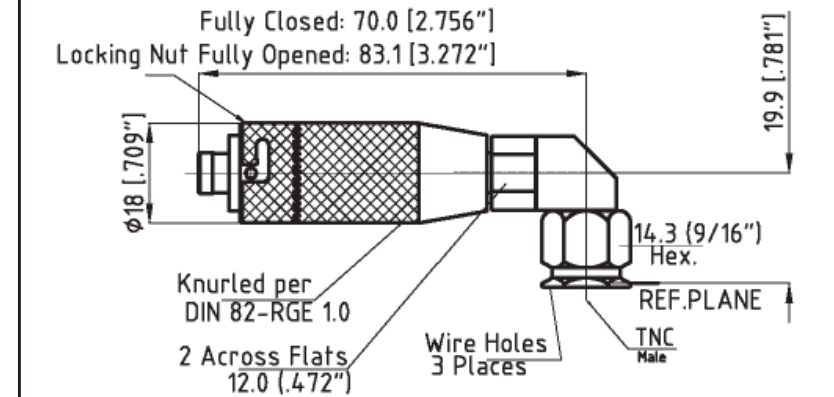

P/N 4090-LC04-02

Phase Adjustable Self Locking Cable Connectors of Type TNC right angle Cable Type 140
 Phase adjustment: 280° max.

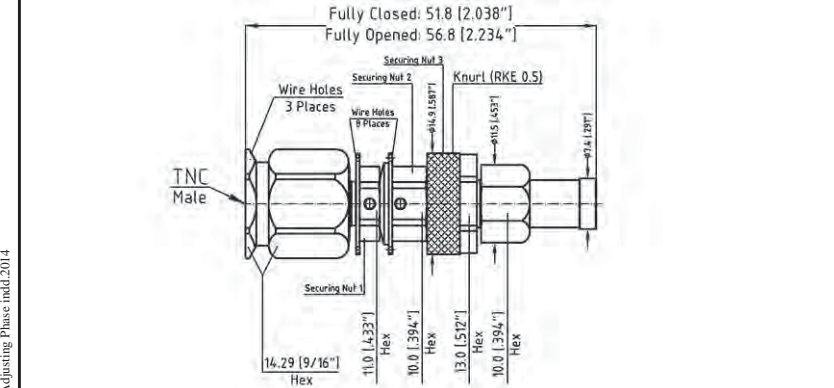

P/N 4015-LC03-02

Phase Adjustable Self Locking Cable Connectors of Type TNC straight Cable Type 100
 Phase adjustment: 100° max.

If you need the phase adjustable connector for another cable?

- Please talk to us, maybe there is only a minor change at an existing design needed
- Is your cable Flexible Cable, or Semi Rigid?

If you need a phase adjustable connector for another connector series?

- Our engineering team will be happy to listen to the details of your need and submit a proposal
- Engineering and Design is our business

TNC Coaxial Phase Adjusters Models as per table to the right	
Cable Type	100, flexible
Frequency Range	DC - 18.0 GHz
Adjustment	see table to the left
Impedance	50 Ohms
Max. VSWR	1.05 + .008f(GHz)
Insertion Loss	(.1 SQT(f(GHz)))dB
R.F. Leakage	-80 dBC
Temperature Range	-65°C to +115°C

Adjusting Phase.indd.2014

Adjusting Phase.indd.2014

Phase Adjustment not at the connectors, but somewhere in the Cable Assembly

The Problem: Long Cable assemblies are being pulled in a system, e.g. in an aircraft. After installation the phase has been changed and needs to be adjusted. As there is no room for phase adjustable connectors at the cable ends the customer has the option to decide about a location where a phase adjuster can be installed in the cable.

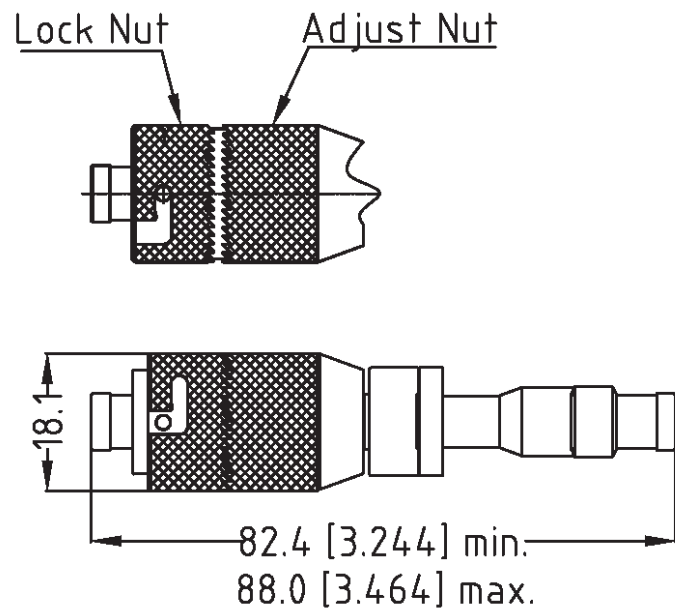

P/N LS-0018-K100, used on Type 100 cable

Adjusting Phase.indd.2014

Double Ridge Waveguides

Designation (WRD)	Waveguide Code	Frequency (GHz)
200 - D24	D200	2.00 - 4.80
350 - D24	D350	3.50 - 8.20
350 - D36	D351	3.50 - 12.40
475 - D24	D475	4.75 - 11.00
500 - D36	D500	5.00 - 18.00
650 - D28	D650	6.50 - 18.00
750 - D24	D750	7.50 - 18.00

End-Launched

WG to Coax Adapters

available with any standard coaxial Connector

Rectangular Waveguides

Designation (WR)	IEC (WG)	IEC (R)	Waveguide Code	Frequency (GHz)
650	6	14	R650	1.12 - 1.70
510	7	18	R510	1.45 - 2.20
430	8	22	R430	1.70 - 2.60
340	9 A	26	R340	2.20 - 3.30
284	10	32	R284	2.60 - 3.95
229	11 A	40	R229	3.30 - 4.90
187	12	48	R187	3.95 - 5.85
159	13	58	R159	4.90 - 7.05
137	14	70	R137	5.85 - 8.20
102			R102	7.00 - 11.0
112	15	84	R112	7.05 - 10.0
90	16	100	R090	8.20 - 12.4
75	17	120	R075	10.0 - 15.0
67			R067	11.0 - 17.0
62	18	140	R062	12.4 - 18.0
51	19	180	R051	15.0 - 22.0
42	20	220	R042	18.0 - 26.5
34	21	260	R034	22.0 - 33.0
28	22	320	R028	26.5 - 40.0
22	23	400	R022	33.0 - 50.0

Top-Launched

Spectrum Elektrotechnik GmbH, P.O.Box 450533, 80905 Munich, Germany
Phone: +49-89-3548-040, Fax: +49-89-3548-0490

Adjusting Phase.indd.2014

I

Coaxial Delay Lines

manufactured to customer's specifications

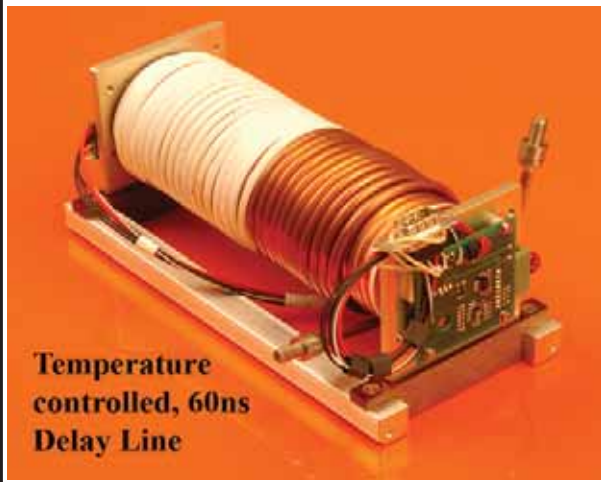

Temperature controlled, 60ns Delay Line



Delay Line 70 ns



19" Drawer for 25 & 50ns Delay Lines



Delay Line, 50ns



200 ns Delay Line



19" Drawer for 100 & 200ns Delay Lines

Adjusting Phase.indd.2014

*Innovation in
Microwave
Engineering*

Hermetically Sealed Adapters



**1.85mm, 2.4mm, 2.92mm,
TNC and N BFJ & 4-H-Flg.**
with & without venting holes, as used at Test Chambers

80905 Munich, Germany

P.O. Box 450533

Telephone: +49-89-3548-040

Facsimile: +49-89-3548-0490

WWW.SPECTRUM-ET.COM

Email: sales@spectrum-et.com

Adjusting Phase.indd.2014

Engineering Perfection

*Striving for Excellence
Exploring new Methods
Generating Solutions
Creating Intelligence*

*Developing products as needed
in your system for
the success of your
Program.*



*The 135° angled Connectors and Adapters
where straight and mitred units do not fit.*

Spectrum
Elektrotechnik GmbH **when Quality is needed**

80905 Munich, Germany

Telephone: +49-89-3548-040

www.spectrum-et.com * Email: Sales@Spectrum-et.com

P.O. Box 450533

Facsimile: +49-89-3548-0490

135GradWinkelE3

Adjusting Phase.indd.2014

**Coaxial Connectors
DC-71 GHz**

**and Adapters
DC-71 GHz**

**Multiport
Assemblies
DC to 40 GHz**

Spectrum
Elektrotechnik GmbH
when quality is needed

**Coaxial
Delay Lines
DC to 40 GHz**

**Cable Assemblies
DC to 71 GHz**

**Waveguide to
Coax Adapters**

**Phase-Adjusters
DC to 63 GHz**

**Gain Amplitude
Equalizers**

Telephone: +49-89-3548-040

Fax: +49-89-3548-0490

Email: Sales@Spectrum-et.com

www.spectrum-et.com

**TAKE
OFF
WITH
OUR
PRODUCTS**

Horst-86E

Adjusting Phase.indd.2014

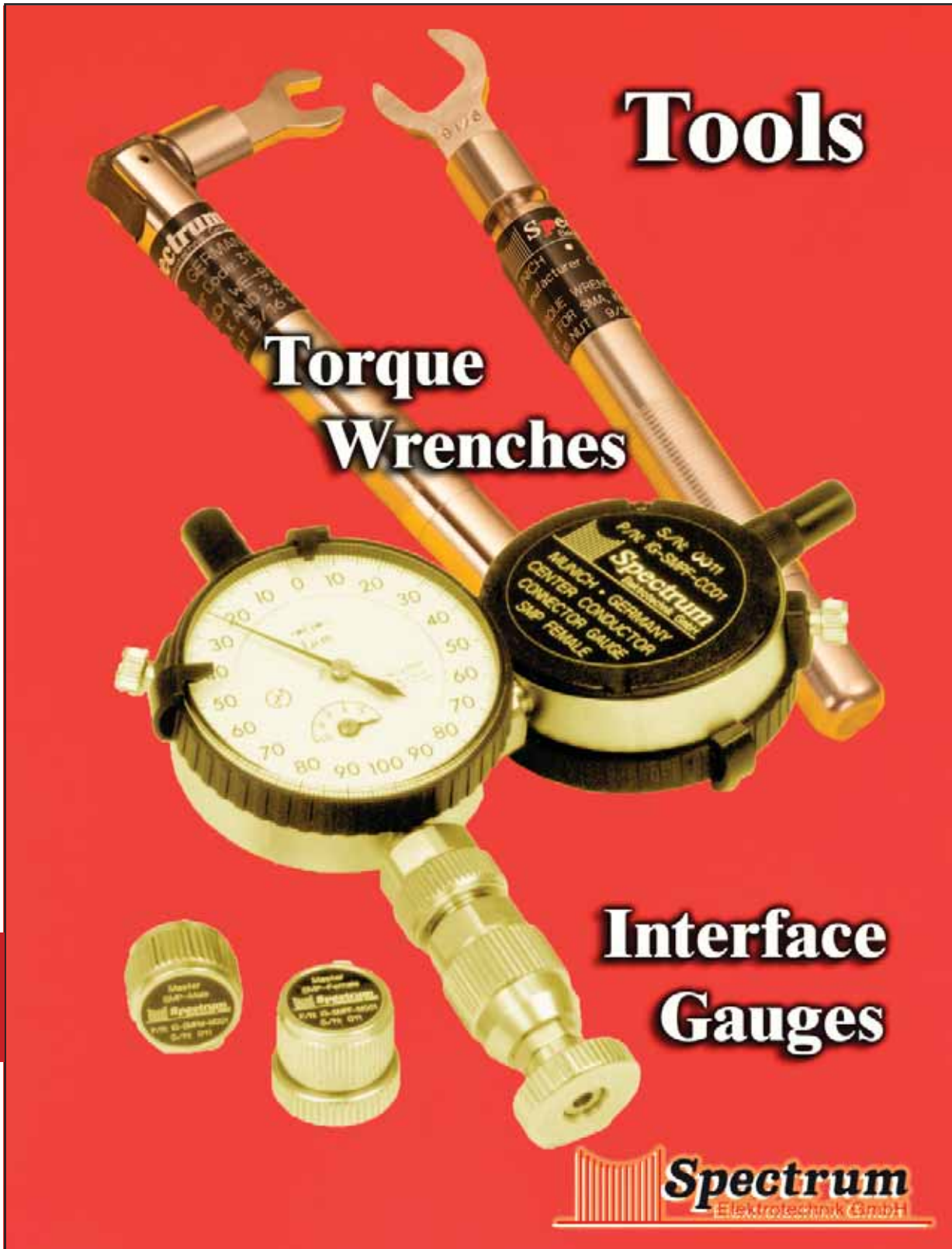

Tools

Torque Wrenches

Interface Gauges

Spectrum
Elektrotechnik GmbH

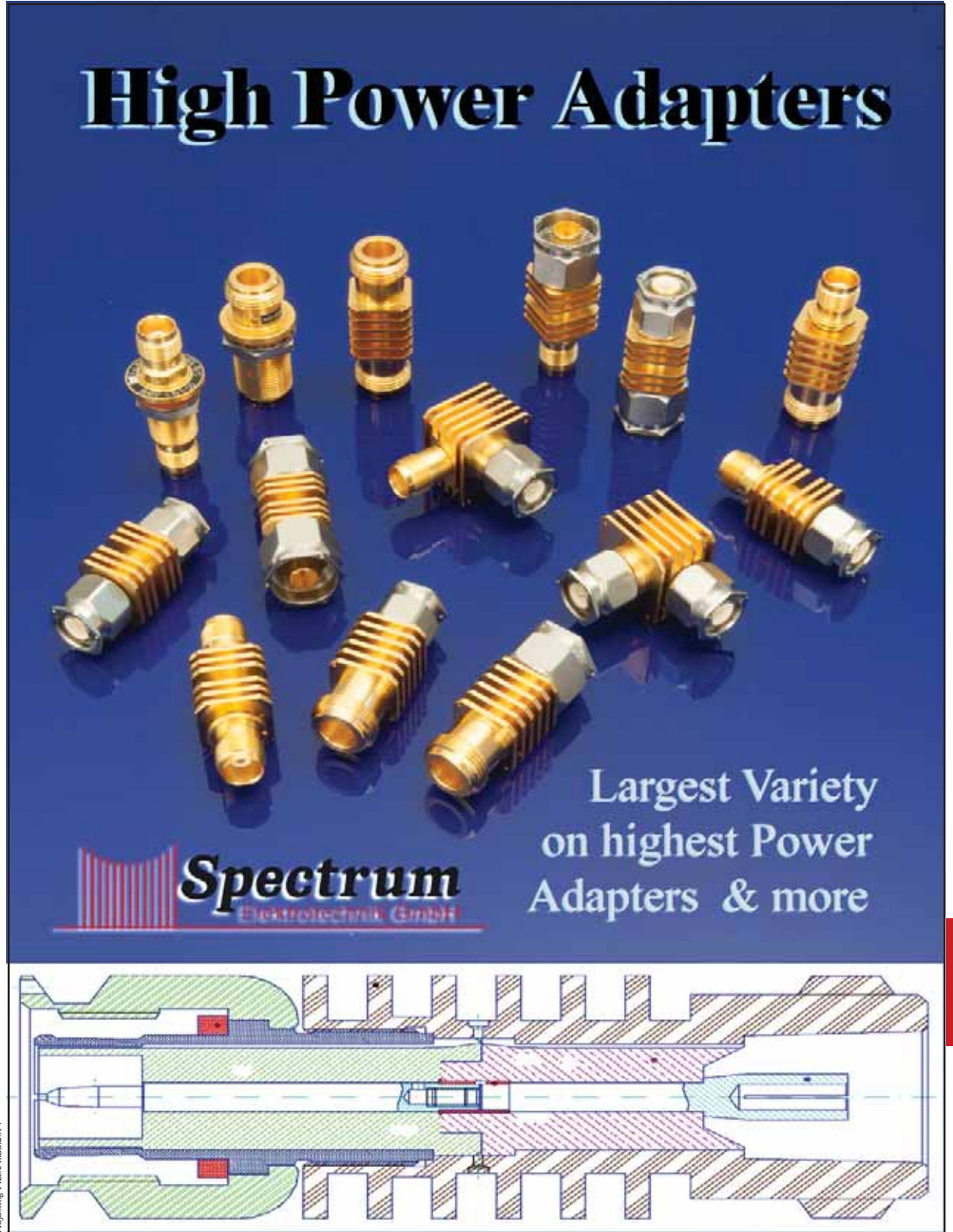

High Power Adapters

Largest Variety on highest Power Adapters & more

Spectrum
Elektrotechnik GmbH

Fine Grain Equalizers and Gain Amplitude Equalizers

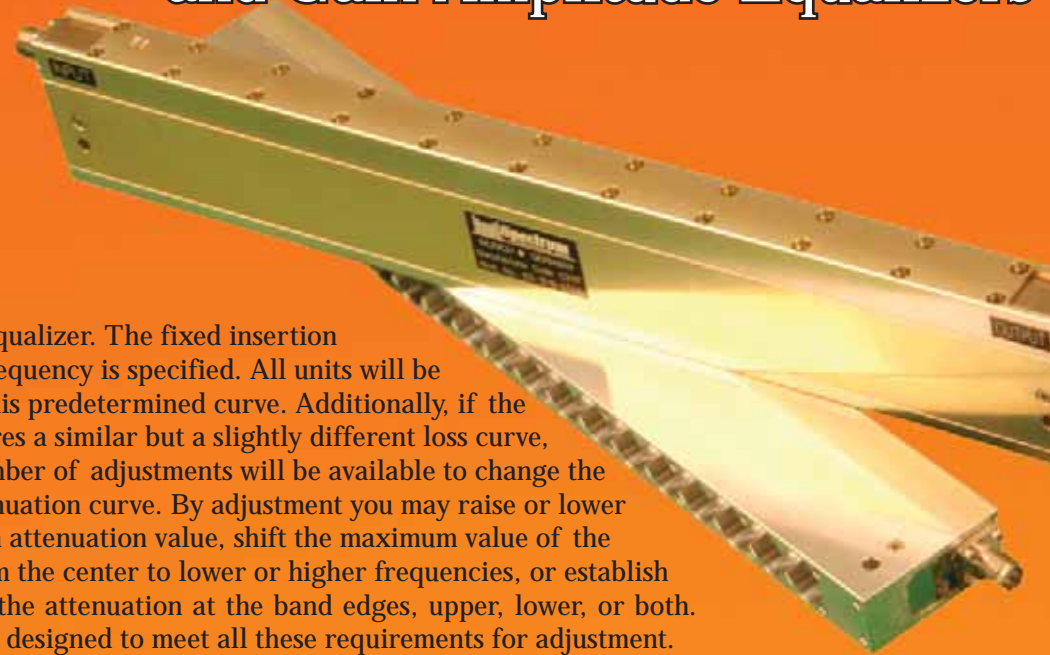

Adjustable Equalizer. The fixed insertion loss versus frequency is specified. All units will be set to meet this predetermined curve. Additionally, if the system requires a similar but a slightly different loss curve, a certain number of adjustments will be available to change the nominal attenuation curve. By adjustment you may raise or lower the maximum attenuation value, shift the maximum value of the response from the center to lower or higher frequencies, or establish a change of the attenuation at the band edges, upper, lower, or both. A unit can be designed to meet all these requirements for adjustment.

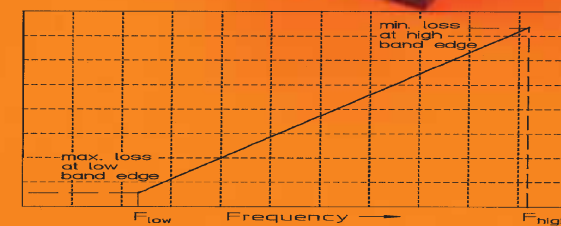
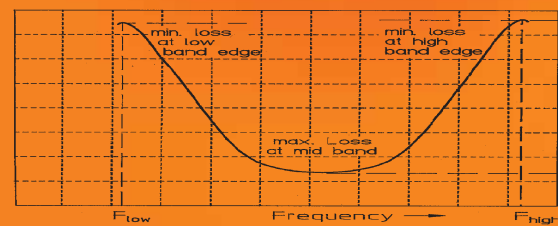

Adjusting Phase.indd.2014

Interface Gauges

A small investment helps avoiding big trouble.



Please see our other products, starting at Connectors, rigid and flexible Cable Assemblies for High Performance, High Power, Phase Stability, Coaxial Adapters, Waveguide to Coax Adapters, Passive Components, such as Phase Shifters, Isolators, Circulators, Terminations, Cal Kits and Super Components.

80905 Munich, Germany

P.O. Box 450533

Telephone: +49-89-3548-040

Facsimile: +49-89-3548-0490

www.spectrum-et.com * Email: Sales@Spectrum-et.com

Interface Gauges

Adjusting Phase.indd.2014

**Never heard of Multiports,
connecting coaxial Cable
Assemblies in Seconds?**



when Quality is needed

80905 Munich, Germany

Telephone: +49-89-3548-040

www.spectrum-et.com

P.O. Box 450533

Facsimile: +49-89-3548-0490

Email: sales@spectrum-et.com

Adjusting Phase.indd.2014

**Are you still Threading?
Torquing? Untorquing?
Unthreading?**

**Never ever heard of
Push-Ons?
Slide On!
Pull Off!
Done!**



**Push - On Connectors do fit all
standard SMA, N, TNC, 7/16**



when Quality is needed

80905 Munich, Germany

Telephone: +49-89-3548-040

WWW.SPECTRUM-ET.COM

P.O. Box 450533

Facsimile: +49-89-3548-0490

Email: sales@spectrum-et.com

Adjusting Phase.indd.2014

Europe

Czech Republic**Abditus Sp. z o.o.**

ul. Gubinska 8/62
54-434 Wroclaw - Poland

Contact: Mr. Thomas Luszpinski
Phone: +48 71-75-034-64
Fax: +48 71-72-313-45
E-mail: info@abditus.pl
Web Page: www.abditus.pl

Italy**Selint S.r.l.**

Via del Fontanile Anagnino 50/52
00118 Roma (Rome) - Italy

Contact: Mr. Roberto Mazza
Phone: +39-679-841-028 / 679-841-418
Fax: +39-679-845-609
Email: info@selint.it
Web Page: www.selint.it

France**Elhyte**

8-10 Rue du Bois Sauvage
Bat Q
91000 Evry - France

Contact: Mr. David Duval
Phone: Tel: +33 (0) 171 63 14 30
Fax: +33-01-690-150-75
E-mail: commercial@elhyte.fr
Web Page: www.elhyte.fr

Poland**Abditus Sp. z o.o.**

ul. Gubinska 8/62
54-434 Wroclaw - Poland

Contact: Mr. Thomas Luszpinski
Phone: +48 71-75-034-64
Fax: +48 71-72-313-45
E-mail: info@abditus.pl
Web Page: www.abditus.pl

Hungary**Abditus Sp. z o.o.**

ul. Gubinska 8/62
54-434 Wroclaw - Poland

Contact: Mr. Thomas Luszpinski
Phone: +48 71-75-034-64
Fax: +48 71-72-313-45
E-mail: info@abditus.pl
Web Page: www.abditus.pl

Slovakia**Abditus Sp. z o.o.**

ul. Gubinska 8/62
54-434 Wroclaw
Poland

Contact: Tomasz Luszpinski
Phone: +48 71 750 3464
Fax: +48 71 723 1345
E-mail: info@abditus.pl

Israel**IMC Microwave industries Ltd.**
LEADING RF & MICROWAVE OEM

6 Nahshon st.
Petach-Tikva, 4927795
Israel

Contact: Mr. Eshel Ayalon
General Manager
Tel: 972-3-9300464
Fax: 972-3-9342056
Email: eshel@imc-mw.co.il
URL: www.imc-mw.com

Spain**ERCOMS Solutions S.L.**

Calle Luis Barahona de Soto
6-Bloque 3, 2-B
29004 Malaga, SPAIN

Contact: Mrs. Estefania Ruiz
Phone: +34 (0)655 - 256 776
eMail: estefania@ercoms.es
URL: www.ercoms.es

Dimensions shown are Inches over Millimeters or vice versa. Standard units have stainless finish (last 2 digits of the P/N are -02). Interfaces are per DIN 47 223, DIN 47 226, IEC 169-4, IEC 169-7, IEC 169-8, IEC 457-2, IEC 60169-5, IEEE 287, MIL-PRF-39012, MIL DTL-24044, MIL DTL-3643, MIL-STD-348B, where applicable

K2 Spectrum Elektrotechnik GmbH • www.spectrum-et.com • Email: sales@spectrum-et.com • Fax: +49 89 354 80490 • Phone: +49 89 354 804-0

Europe

UK**Microtek Components Ltd**

Unit 25 Kingfisher Court
Hambridge Road
Newbury, Berkshire, RG14 5SJ

Contact: Mr. Abdreu Sanders; Mr. Rob Valentine
Phone: +44 (0)1635 522292
Fax: +44 (0)1635 524174
Email: rob@microtekcomps.co.uk
Web: www.microtekcomps.co.uk



We are looking for additional Reps & Distributors in Europe and world-wide.

Can you help ?

Dimensions shown are Inches over Millimeters or vice versa. Standard units have stainless finish (last 2 digits of the P/N are -02). Interfaces are per DIN 47 223, DIN 47 226, IEC 169-4, IEC 169-7, IEC 169-8, IEC 457-2, IEC 60169-5, IEEE 287, MIL-PRF-39012, MIL DTL-24044, MIL DTL-3643, MIL-STD-348B, where applicable

Spectrum Elektrotechnik GmbH • www.spectrum-et.com • Email: sales@spectrum-et.com • Fax: +49 89 354 80490 • Phone: +49 89 354 804-0 K3

United States of America

Centre frequency Technical Marketing

PO Box 229
125 South Pennsylvania Ave.
Centre Hall, PA 16828, USA
Representative for all Spectrum products in the following mentioned cities/territories in the United States:
- Pennsylvania
- Southern New Jersey
- Delaware
Contact: Richard P. Whitman
Phone: +1 814 - 364 9867
eMail: rwhitman@cf-tm.com

WILSON CO.

PO Box 466
Towaco, NJ 07082, USA
Representative all Spectrum products in the following mentioned cities/territories in the United States:
- New York
- Northern New Jersey
- Connecticut
Contact: George Wilson
Phone: +1 973 - 335 3550
Fax: +1 973 - 335 3980
eMail: gwwilsonco@aol.com

We are looking for additional Representatives in the USA



Dimensions shown are Inches over Millimeters or vice versa. Standard units have stainless finish (last 2 digits of the P/N are -02). Interfaces are per DIN 47 223, DIN 47 226, IEC 169-4, IEC 169-7, IEC 169-8, IEC 457-2, IEC 60169-5, IEEE 287, MIL-PRF-39012, MIL DTL-24044, MIL DTL-3643, MIL-STD-348B, where applicable

K4 Spectrum Elektrotechnik GmbH • www.spectrum-et.com • Email: sales@spectrum-et.com • Fax: +49 89 354 80490 • Phone: +49 89 354 804-0

Asia

Shanghai Fintest Technology Development Co., Ltd.
Room A1216, Tomson Centre
No.188 Zhang Yang Road
201318 Shanghai, CHINA

Representative and Distributor for all Spectrum products in the following mentioned cities/territories in China:
- Shanghai
- Nanjing (province of Jiangsu)
- Chengdu (province of Sichuan)
- Kanton (province of Guangdong)

Contact: Mr. Henry Yu, Mr. Benson Liu
Phone: +86 (0)21 - 6838 0250
Fax: +86 (0)21 - 6838 0251
eMail: sales@fin-test.com
URL: <http://www.fin-test.com/EN/>

Shenzen Hanlunda Industrial Co., Ltd.
Rm USTV, 11/F., Block A, Fortune Plaza
No.7002 Shennan Road, Futian District
518040 Shenzen, CHINA

Representative and Distributor for all Spectrum products in the following mentioned cities/territories in China:
- Province Anhui
- Beijing
- Province Hebei

Contact: Mr. John Yu
Phone: +86 (0)755 - 8302 1316, 8302 1690, 8287 9200
Fax: +86 (0)755 - 8302 1987
eMail: john@hanlunda.com
URL: <http://www.hanlunda.com>

CHINA

Shenzhen Unibetter Electronics Co. Ltd.
Room 2008-2015, Fu Ji Park Building
No. 1008, Bu Ji Road, Luo Hu District
518003 Shenzhen, Guangdong, CHINA

Representative and Distributor for all Spectrum products, but only in cities and territories not mentioned at the other Chinese reps.

Contact: Mrs. Cissie Liu
Phone: +86 (0)755 2542-9125, Exit:606
Fax: +86 (0)755 - 2542 9135
eMail: sales@unibetter-ic.com
URL: <http://www.unibetter-ic.com>

ShangHai HangOu Mechanical And Electrical Equipment Co. Ltd
Room 905, Building No.1, Guoson Centre
Lane 388, Zhongjiang Road
200062 Shanghai, CHINA

Distributor only for Spectrum Tools

Contact: Mrs. Lisa Zou
Phone: +86 (0)21 - 5108 5161, +86 (0)21 - 5239 1901
Fax: +86 (0)21 - 5187 0910, +86 (0)21 - 5239 1837
eMail: sales@shhangou.com, sales@shhangou.com.cn
URL: <http://www.shhangou.com>, <http://www.shhangou.com.cn>

INDIA

Deltronic Marketing Corporation

DMC Centre
49 Entrenchment Road
Secunderabad 500 026, INDIA

Contact: Mr. Dev Kushlani
Phone: +91 (0)40 - 2773 1530, 2773 2993
Fax: +91 (0)40 - 2773 2864, 2773 1248
eMail: dk@deltronic.in
URL: <http://www.dmcindia.in>

JAPAN

AmTechs Corporation

5-20-16, Kyodo, Setagaya-ku
Tokyo 156-0052, JAPAN

Contact: Mr. Ken Satoh
Phone: +81 (0)3 - 5450 5311
Fax: +81 (0)3 - 5450 5312
eMail: rf@amtechs.co.jp
URL: <http://www.amtechs.co.jp>

Dimensions shown are Inches over Millimeters or vice versa. Standard units have stainless finish (last 2 digits of the P/N are -02). Interfaces are per DIN 47 223, DIN 47 226, IEC 169-4, IEC 169-7, IEC 169-8, IEC 457-2, IEC 60169-5, IEEE 287, MIL-PRF-39012, MIL DTL-24044, MIL DTL-3643, MIL-STD-348B, where applicable

Spectrum Elektrotechnik GmbH • www.spectrum-et.com • Email: sales@spectrum-et.com • Fax: +49 89 354 80490 • Phone: +49 89 354 804-0 K5

Asia

MALAYSIA

Wiselink Technolgy SDN BHD

12 Jalan Mutiara Emas 5/14, Taman Mount Austin
81100 Johor Bahru, Johor, MALAYSIA

Phone: +607 - 3556 116
Fax: +607 - 2875 233
eMail: wmsales@wiselink.com.sg
URL: <http://www.wiselink.com.sg>

SOUTH KOREA

UNIWAVES

Suite 16-231 International Distribute Complex
LSro92 Anyang
14117 KOREA

Contact: Mr. J.C. Kim
Phone: +82 (31) - 427 82 69
Fax: +82 (31) - 427 82 68
eMail: jckim@uniwaves.co.kr

RUSSIA

NKT ZAO

Dolgorukovskaya 40, Building S
127006, Moscow, RUSSIA

Contact: Mr. Alexey Gavrilov
Phone: +7 (495) - 787 05 50
Fax: +7 (495) - 787 77 82
eMail: info@nkt-rf.ru
URL: <http://www.nkt-rf.ru>

THAILAND

Wiselink Technology (Thailand) Co., Ltd.

292/11 Moo 4, Taladbangkhen, Lakxi
Bangkok 10210, THAILAND

Phone: +66 (0)2 - 552 52 07
Fax: +66 (0)2 - 552 89 91
eMail: wtsales@wiselink.com.sg
URL: <http://www.wiselink.com.sg>

SINGAPORE

Wiselink Technology PTE Ltd. (HQ)

629 Aljunied Road
07-05 Cititech Induatrial Building
Singapore 389838, SINGAPORE

Contact: Mr. Robert Lim, Managing Director
Phone: +65 - 674 660 66
Fax: +65 - 674 660 77
eMail: sales@wiselink.com.sg
URL: <http://www.wiselink.com.sg>

Dimensions shown are Inches over Millimeters or vice versa. Standard units have stainless finish (last 2 digits of the P/N are -02). Interfaces are per DIN 47 223, DIN 47 226, IEC 169-4, IEC 169-7, IEC 169-8, IEC 457-2, IEC 60169-5, IEEE 287, MIL-PRF-39012, MIL DTL-24044, MIL DTL-3643, MIL-STD-348B, where applicable

K6 Spectrum Elektrotechnik GmbH • www.spectrum-et.com • Email: sales@spectrum-et.com • Fax: +49 89 354 80490 • Phone: +49 89 354 804-0

DC to 70 GHz



Multiport Assemblies
DC to 40 GHz

Adapters
DC to 70 GHz



Coaxial Delay Lines
DC to 40 GHz

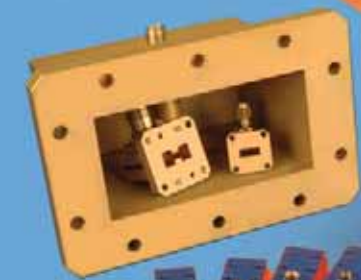

Waveguide to Coax Adapters



Gain Amplitude Equalizers

Phase-Adjusters
DC to 63 GHz



Telephone: +49-89-3548-040
Fax: +49-89-3548-0490
Email: Sales@spectrum-et.com

www.spectrum-et.com

RELIABLE DESIGNS YOU CAN TRUST

TAKE OFF WITH OUR PRODUCTS

General Terms and Conditions



Ordering

Please include both, Spectrum Elektrotechnik GmbH part number, and a description of the item(s) ordered. If special features are required, describe them as completely as possible and include an engineering sketch. Orders may be placed directly with the factory in Munich or with any authorized Spectrum Elektrotechnik GmbH Representative. Minimum Factory Order is 150 Euro.

Acceptance of Orders

All orders are subject to acceptance at the discretion of the factory and with an Order Acknowledgment from Spectrum Elektrotechnik GmbH.

Terms

Upon approval of credit, payment is due Net 30 days from date of invoice. Late payments are subject to a 1.5 % monthly charge on past due balances.

Shipments

Spectrum Elektrotechnik GmbH ships via the most expedient reliable carrier. Shipment F.C.A. or F.O.B., Spectrum Elektrotechnik GmbH plant, will be sent freight prepaid and billed unless other prior arrangements are made. Spectrum Elektrotechnik GmbH will use any acceptable method of delivery specifically requested by customer.

Damaged Materials/Shortages

All orders should be inspected upon receipt for both completeness and to insure receipt of materials in proper condition. All claims for shortages must be made within thirty (30) days after date of shipment of material from Spectrum Elektrotechnik GmbH plant. Title to goods passes to the Buyer upon delivery to the carrier and risk of loss or damage shall thereafter rest with the Buyer. Claims for damage or loss while material is in transit must be made against the carrier by the Buyer.

Warranty

Spectrum Elektrotechnik GmbH warrants products of its manufacture to be free from defects in material and workmanship under conditions of normal use. If, within one year after delivery of the original owner and after prepaid return by the original owner, any Spectrum Elektrotechnik GmbH product is found to be defective, Spectrum Elektrotechnik GmbH shall, at its option, repair or replace said defective item. This warranty does not apply to products which have been disassembled, modified or subjected to conditions exceeding the applicable specifications or ratings.

Cancellation

Cancellation of, or changes to an order acknowledged by Spectrum Elektrotechnik GmbH are accepted only upon terms that protect Spectrum Elektrotechnik GmbH against loss.

Returns

Excess or unused material cannot be returned for credit without factory authorization. Such material is subject to a handling charge of not less than 15 % upon return and inspection of material at the factory. In no case will Spectrum Elektrotechnik GmbH authorize return of material beyond ninety (90) days after shipment from the factory. Credit for returned material is issued by Spectrum Elektrotechnik GmbH only to the original purchaser. Freight charges for returned material is the responsibility of the Buyer.

Defective Material

Claims for defective material or workmanship are subject to verification by Spectrum Elektrotechnik GmbH Quality Control, and must have prior factory authorization. Upon verification, Spectrum Elektrotechnik GmbH reserves the right to repair or replace, as deemed necessary.

Prices / Specifications

Unless otherwise specified, prices quoted are F. O. B. Spectrum Elektrotechnik GmbH plant. Both prices and specifications are subject to modification without prior notice.

Patent and Trademark Indemnity

Buyer agrees at Buyer's expense to protect and defend Seller against any and all claims of patent or trademark infringement arising from Seller's compliance with Buyer's designs or specifications or instruction and to hold Seller harmless from all losses, damages, costs and expenses attributable to any such claim or claims. Seller shall have the right to approve or disapprove counsel designated by Buyer to defend such claims.

Spectrum Elektrotechnik GmbH reserves the right to make design changes without notice on any of its products and without any obligation to make same or similar changes to items previously purchased. In no event does Spectrum Elektrotechnik GmbH assume liability for installation labor or for consequential damages. This warranty is the extent of the obligation or liability assumed by Spectrum Elektrotechnik GmbH with respect to its products, and no other warranty or guarantee is either expressed or implied.

Catalogues



Spectrum Elektrotechnik GmbH is a leading manufacturer of RF and Microwave Components in the Frequency Range of DC to 71.0 GHz. The products are published in seven individual catalogs and one Product Portfolio, showing detailed information and comprehensive data.

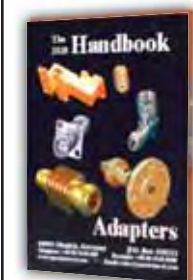

Adapters,
DC - 70 GHz, 50 Ohms
Coaxial Adapters (In Series and Between Series)
Hermetically Sealed Adapters
High Power Adapters
Push-On Adapters
Waveguide to Coax Adapters



Cable Assemblies,
DC - 70 GHz, 50 Ohms
ANA Test Cables
Flexible Cable Assemblies
Low Loss Cable Assemblies
Phase Stable Cable Assemblies
Semi Rigid Cable Assemblies
(Dia. 0.34" to 1")



Circulators and Isolators
Connectorized Isolators and Circulators
Drop In Isolators and Circulators
Lumped Design Isolators

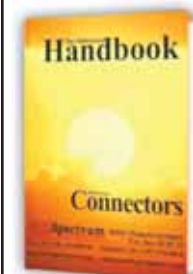

Connectors,
DC - 70 GHz, 50 Ohms
Blind Mate Connectors
Coaxial Connectors
High Power Connectors
Multi Pin Connectors
Push-On Connectors



Adjusting Phase
DC - 63 GHz, 50 Ohms
Phase Adjustable Connectors
Phase Adjustable Adapters

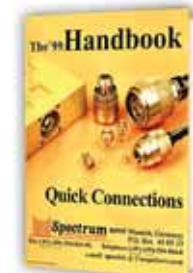

Quick Connections,
DC to 65 GHz, 50 Ohms
Blind Mate Connectors
Multi Coax Connections,
SQ-, TQ-, IQ-, BQ-, CQ-, and RQ-Series,
Push - On Adapters, Connectors,
and Push-On Cable Assemblies



Test Necessities and Accessories,
DC - 71 GHz, 50 Ohms
LRL, TRL Calibration and Verification Kits
ANA Cable Assemblies
Torque Wrenches
Interface Gauges
Calibration Kits
Terminations



Adjusting Phase
DC - 63 GHz, 50 Ohms
Phase Adjustable Connectors
Phase Adjustable Adapters



Product Portfolio
Coaxial Connectors and Adapters
Multiport Assemblies
Coaxial Delay Lines
Waveguide to Coax-Adapters
Phase Adjusters
Gain Amplitude Equalizers
Cable Assemblies etc.

**Adapters, Attenuators, Blind Mate Connectors
Cable Assemblies, Connectors, Delay Lines
Duplexers, Equalizers, Fine Grain Equalizers
Gain Ampl. Equalizers, Line Stretchers
Machines, Phase Adjusters
Push-Ons, Terminations
Tools, Waveguide-Coax**



**KW to W mW
MHz to 71 GHz**



Spectrum when Quality is needed
Elektrotechnik GmbH

80905 Munich, Germany

Telephone: +49-89-3548-040

WWW.SPECTRUM-ET.COM

P.O. Box 450533

Facsimile: +49-89-3548-0490

Email: sales@spectrum-et.com