

Focusing Lens Horn Antenna

3.95 to 5.85 GHz, WR187

DESCRIPTION

Anteral's Focusing Lens Horn Antennas are conical horn antennas with a **double-convex** high-density polyethylene (HDPE) lens added in the aperture, in order to apply phase correction and achieve superior focusing performance with minimum size.

The FLHA-F-WR187 model operates at the C-band between 3.95 and 5.85 GHz with a focal length of 203 mm and a diameter beam focus of 67 mm.

APPLICATIONS

Focusing Lens Horn Antennas are especially useful when focusing beam is required with short focal distances. Therefore, these antennas are widely used in testing and material characterization.

Anteral also offers their **Lens Horn Antennas** with plano-convex lenses to exhibit high gain (>30 dB) in a very compact size which makes them optimal for radar applications, communication links or meteorological systems among others.

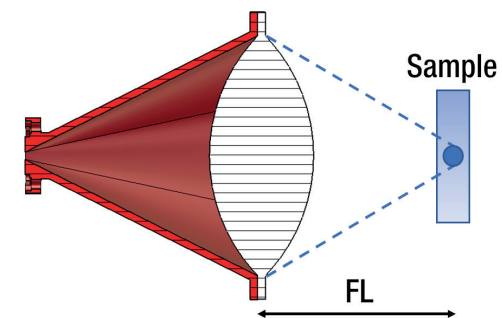

ELECTRICAL SPECIFICATIONS

Parameter	Typical value
Frequency	3.95 - 5.85 GHz
Focal Length	203.6 mm *
3 dB Beamwaist, E-plane	67.57 mm *
3 dB Beamwaist, H-plane	67.1 mm *
S11	-18 dB

*at central frequency

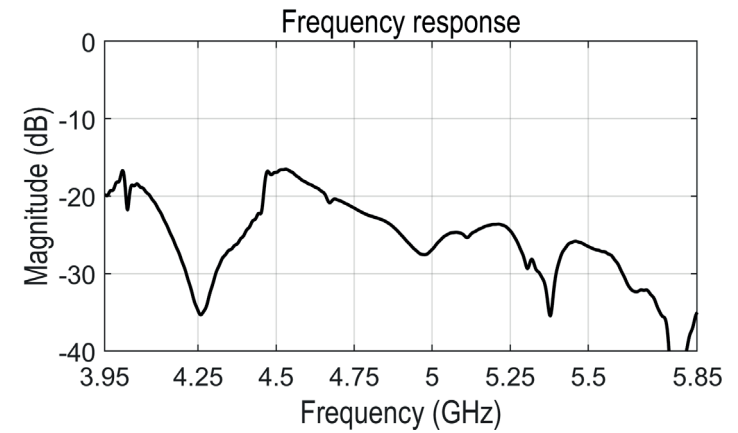
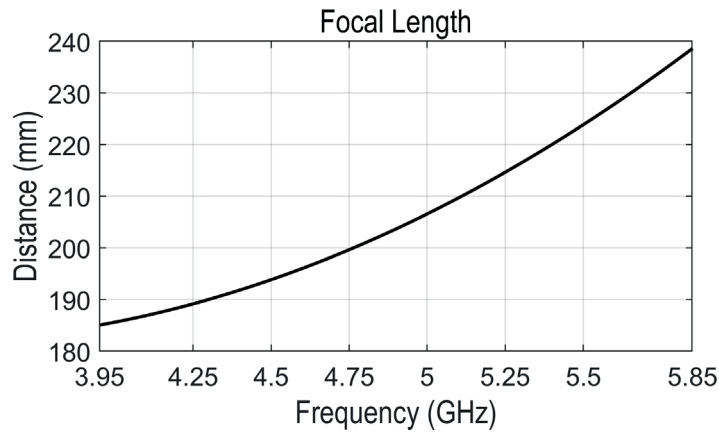
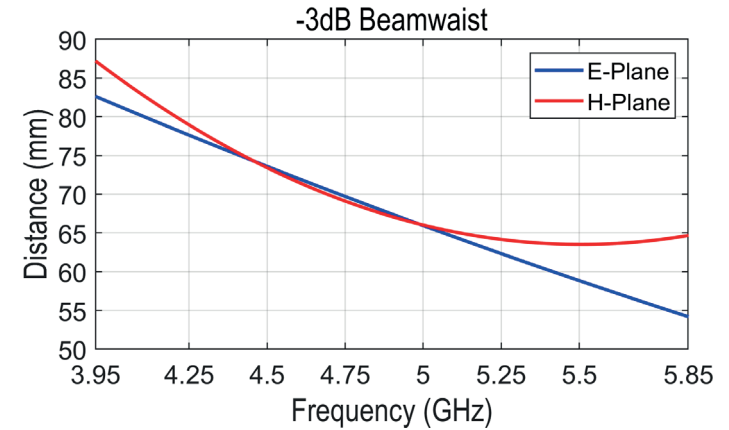

MECHANICAL SPECIFICATIONS

Parameter	Description
Antenna Port*	WR-187 (47.5488 mm x 22.1488 mm)
Flange	UAR 48
Total length	476 mm
Total diameter	324 mm
Total weight	6000 g
Horn Material	Aluminum
Lens Material	HDPE
External Color	Ruby Red

*The antenna includes a rectangular to circular waveguide transition (WR-137 to WC-60.6)

MECHANICAL OUTLINE

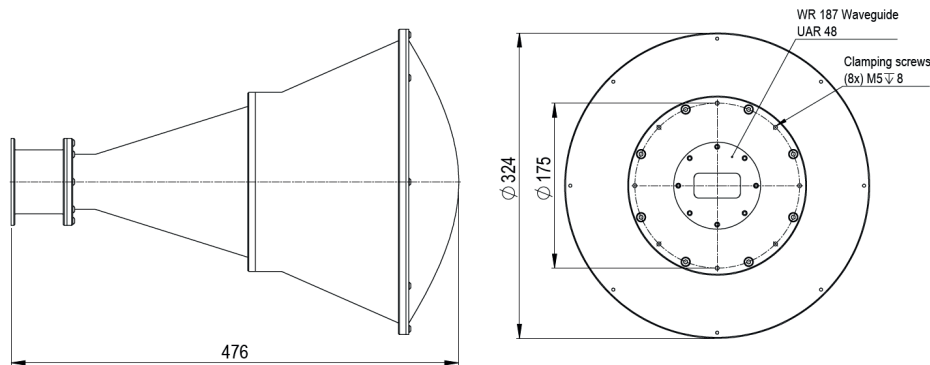

CLAMPING STRUCTURE

Anteral's Lens Horn Antennas are drilled with some threads for clamping purpose. See the mechanical outline.
Anteral also offers clamping structure for the LHA-F-WR187 with the following specifications.

Model	Material	Weight (g)
LHA-F-WR187-CLAMP	Aluminum	1300

*The base is drilled with 4 through holes but any custom holes can be added.

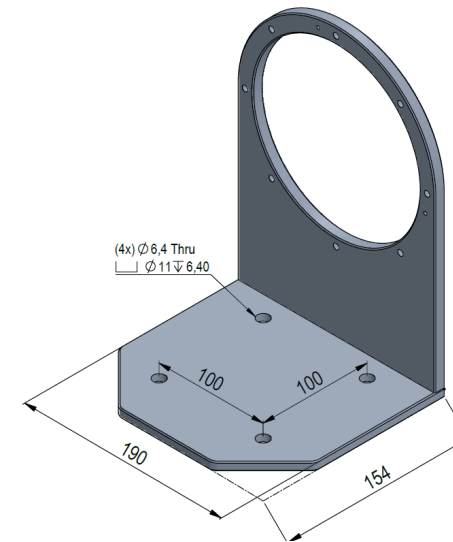

Additional notes

Focal length, beamwaist and return loss data simulated. Actual values could vary slightly.
The return loss performance of all items is checked before delivery.

Last version: 19/05/2026.

