

# Integrated Mixer / Amplifier / Multiplier Chain (MixAMC-I) Operational Manual



---

979 Second Street SE, Suite 309  
Charlottesville, VA 22902-6172 (USA)  
Tel: 434.297.3257; Fax: 434.297.3258  
[www.vadiodes.com](http://www.vadiodes.com)

---

## Contents

<b>Section 1 – Introduction</b> .....	<b>Pages 2-4</b>
Contents .....	Page 2
MixAMC-I General Overview.....	Page 3
Safety and Operational Guidelines .....	Page 4
<b>Section 2 – Product Views, Block Diagrams and Specifications</b> .....	<b>Pages 5-8</b>
Product Overview.....	Page 5
Module Details – Front and Rear Panel Connections, Block Diagram .....	Page 6
Double Sideband Down-Conversion .....	Page 7
General Specifications and Technical Notes .....	Page 8
<b>Section 3 – Operational Procedures</b> .....	<b>Page 9</b>
General Operating Procedures .....	Page 9
<b>Appendix 1 – MixAMC-I SSB Conversion Loss</b> .....	<b>Pages 10-15</b>
MixAMC-I SSB Conversion Loss Performance.....	Page 10-15
<b>Appendix 2 – Conversion Loss vs. IF Frequency</b> .....	<b>Page 16</b>
Conversion Loss vs. IF Frequency .....	Page 16
<b>Appendix 3 – How to Order</b> .....	<b>Page 17</b>
How to Order .....	Page 17
<b>Addendum – Product Updates and Company Contacts</b> .....	<b>Page 18</b>

# MixAMC-I General Overview

## Integrated Mixer / Amplifier / Multiplier Chains

Virginia Diodes' integrated mixer / amplifier / multiplier chains are used to down-convert millimeter-wave / THz signals to a lower frequency range, where it can be coupled into the RF port of an analyzer or processed by other means. By varying the LO frequency, the frequency of the down-converted signal can be adjusted. VDI offers MixAMC-I units from WR15 (50-75 GHz) through WR1.0 (750-1100 GHz).

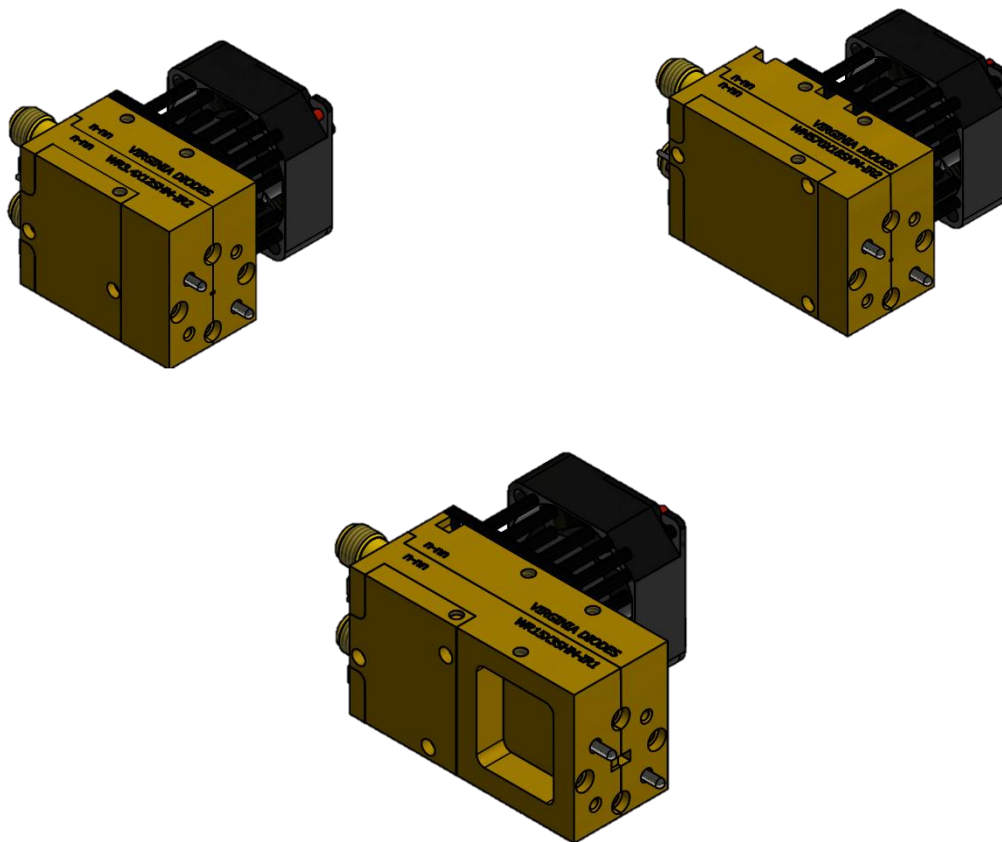

# Safety and Operational Guidelines

 Read all instructions and information in this product manual before connecting a module to its power supply or a signal generator. Operational procedures must be followed for proper function. If you have questions, contact VDI before supplying power to or otherwise operating any VDI module.

 VDI assumes the customer is familiar with microwave, millimeter wave and VDI products in general. The user and customer are expected to understand all safety guidelines, health hazards and general advisories that may exist and are associated with the use of this device. VDI is not responsible for any human hazards that may exist or may occur while using this device.

## RF Drive Limitations

 Recommended RF input power specifications are noted on the label on every VDI module. See example on Page 8; these values provide optimal performance. Irreversible damage can result if input power exceeds stated damage threshold.

## Virginia Diodes, Inc. (VDI) accepts no liability for damage or injury resulting from or caused by:

- Improper operation, disassembly or use for purposes other than those for which the module was designed.
- Use outside common safety, health or general advisories pertaining to microwave, millimeter wave and VDI products
- Repairs carried out by persons other than VDI or its assigned agents.

## Waveguide Inspection / Test Port Care

- Inspect waveguide flanges prior to making connections.
- Waveguide screws should be torqued in the range 20-50 cNm, greater torque can damage the interface.
- Making a connection with metal debris between the waveguide flanges can damage the waveguide interface and prevent repeatable connections.
- If debris is present, clean the flange with pre-dampened TexWipe wipes or swabs (e.g. Part Number TX1065).
- If these are not available, TexWipe cloths lightly dampened with ethanol may be used (e.g. Part Number TX604).
- Replace dust caps when the system is idle.

## General Operating Practices and Recommendations

- VDI MixAMC-I modules are intended to be used in typical laboratory conditions.
- Use of any attachments and accessories not authorized by VDI or that do not meet VDI's specifications may void a module's limited warranty and could pose a hazard to the operator or cause lasting damage to the device.
- Disassembling a module can cause lasting damage to components and pose a hazard to the operator.
- Applying liquids (other than the TexWipe wipes/cloths used for cleaning) can cause lasting damage to the module.
- VDI does not recommend the use of liquid or paste for either thermal grounding of VDI components or for locking screws. Liquids/pastes wicking into the VDI component can damage the internal devices and worsen performance.
- Check with VDI before any measurement connection is attempted beyond those described in this manual or if it may exceed commonly accepted standards of practice.
- Use a torque of 90 cNm when making coaxial connections. Avoid sharp bends in cables.

## Recommended Soldering Guidelines

- Follow manufacturer's recommendations where applicable.
- Do not put any rotational stress on the solder pin.
- Use a temperature-controlled soldering iron with a wedge tip set for 275°C. Dwell time for soldering should be no longer than 5 seconds. To avoid cold solder joints, the dwell time may be extended to 7 seconds safely when using a heat sink clamp on the solder pins. Also, the iron temperature may be increased to no more than 295°C for 5 seconds with the use of a heat sink clamp.
- Allow the solder to cool naturally. Clean the flux from the solder joint only after the pin and filter body have cooled to room temperature.
- Use wire gauge between 22AWG and 24AWG.
- Use Sn60/Pb40, Sn63/Pb37, Sn62/Pb36/Ag2, or Sn96.5/Ag3/Cu0.5 0.38mm solders.
- Place a small heat sink clamp between the filter body and wire attachment location whenever possible.

Typical MixAMC-I modules are shown. The exact equipment delivered may vary.

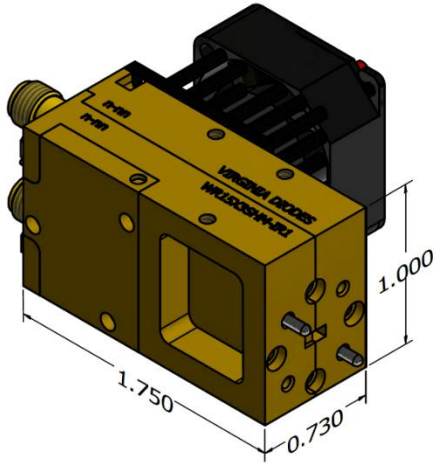

**WR15, WR12, WR10, WR8.0, WR5.1**

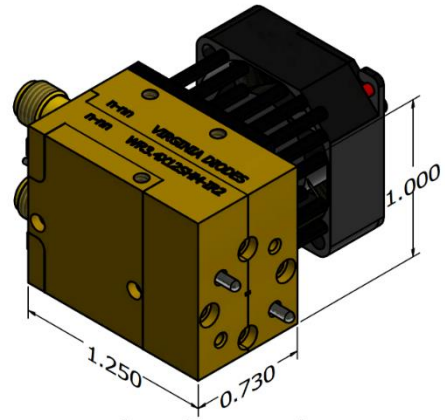

**WR4.3, WR3.4, WR2.8**

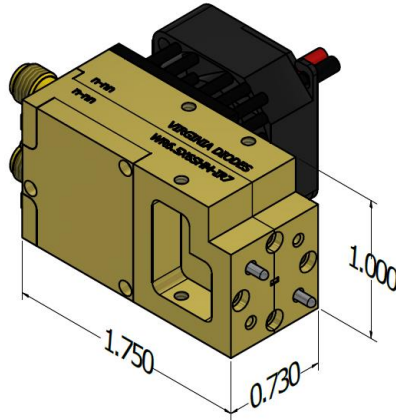

**WR6.5**

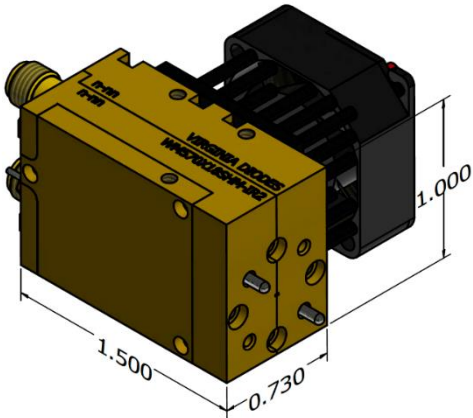

**WR2.2**

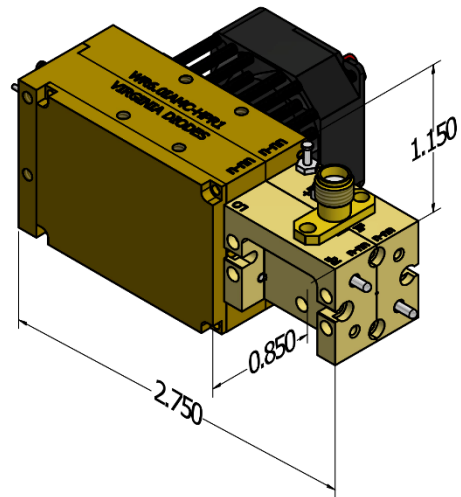

**WR1.5, WR1.0**

*Dimension Units: Inches*

# Front and Rear Panel Connections, Block Diagram

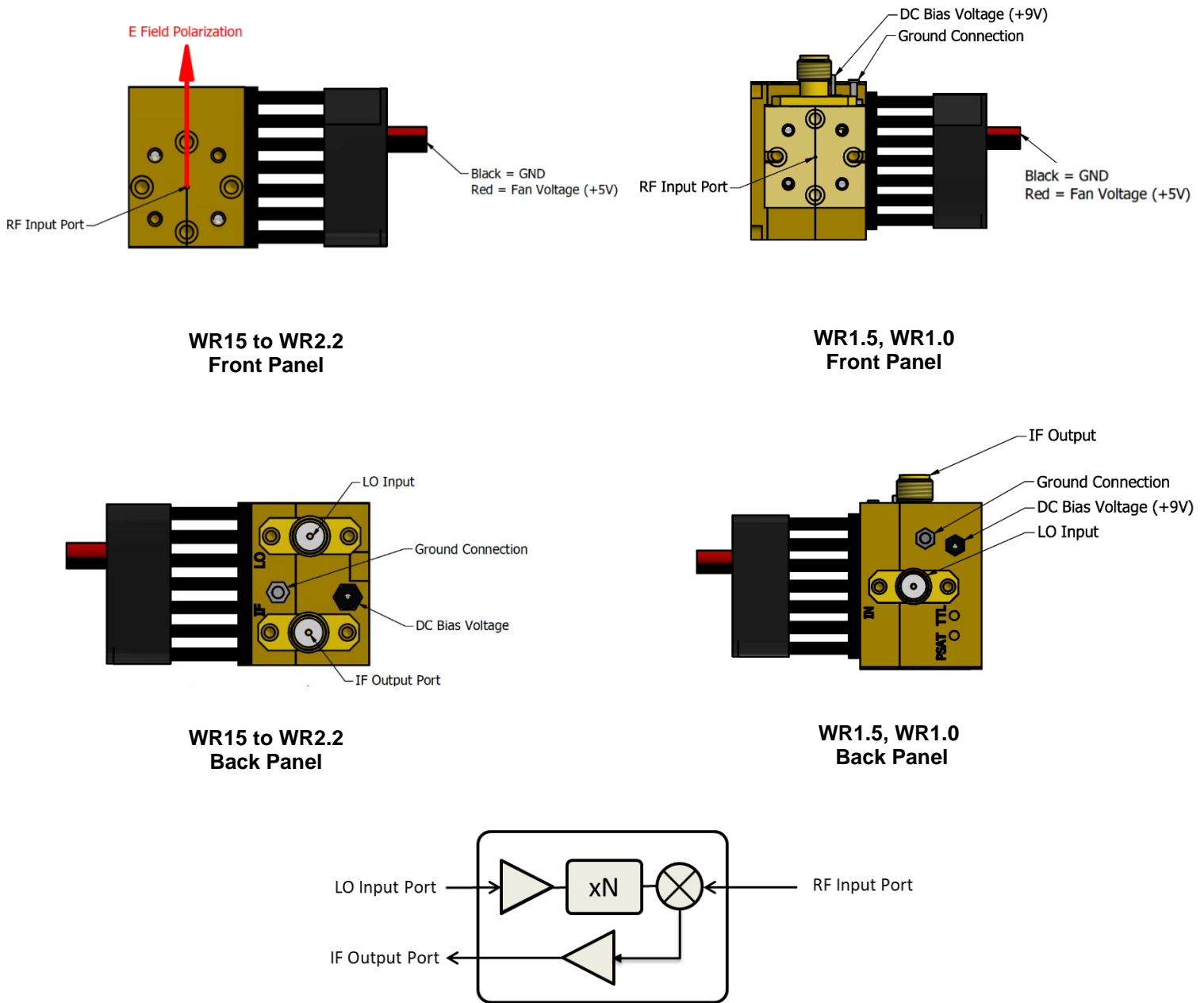

**Figure 1: MixAMC-I Block Diagram**

Simplified block diagram for a typical MixAMC-I module is shown. Location of power amplifiers and multipliers vary for each unit. N is the harmonic factor for this configuration. The standard MixAMC-I configuration comes with an integrated IF amplifier. The MixAMC-I can be configured without the IF amplifier (part number: MixAMC-I-N), allowing for direct access to the mixer IF port.

Please refer to Page 4 for VDI Recommended Soldering Guidelines. Please follow appropriate guidelines when soldering to DC Bias Voltage and Ground Connection pins.



# Double Sideband Down-Conversion

VDI MixAMC-Is can be used to down-convert a block of millimeter-wave / THz signals to the IF band, where it can then be coupled into the RF port of an analyzer or processed by other means.

## Block Down-Conversion

Figure 2 shows how a VDI MixAMC-I or MixAMC-I-N down-converts a block of millimeter-wave signals. It is important to note that due to the double sideband nature of the mixer, the mixer will process both sidebands. The upper and lower sidebands will be down-converted to the same range of IF output frequencies.

The IF Output frequency can be calculated by:  $f_{IF} = |f_{RF} - N \cdot f_{LO}|$ , where N is the total harmonic factor of the unit.

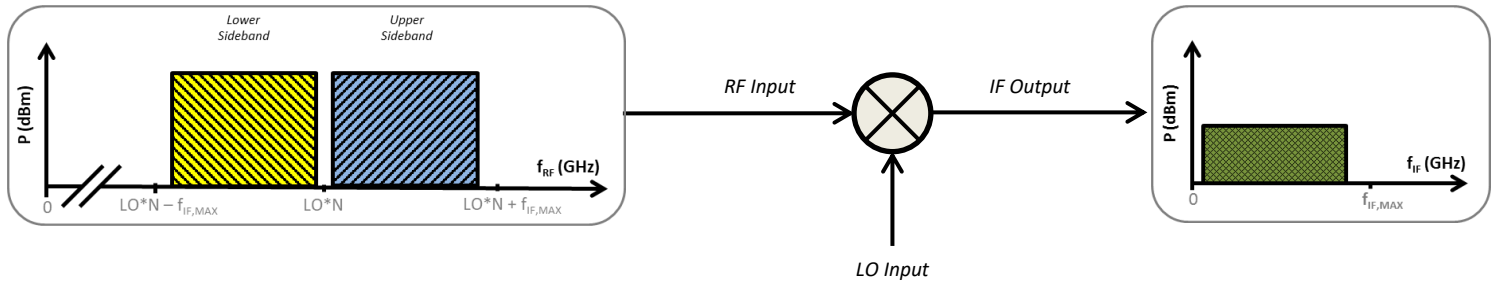
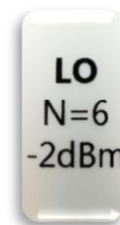

Figure 2: Diagram of block down-conversion is shown.

# General Specifications and Technical Notes

General Specifications Integrated Mixer / Amplifier / Multiplier Chains			
Description		Specification	Connector
LO Input Port	Standard Harmonic Factor (Typical / Damage)	0dBm ± 3dB / 6 dBm	2.92mm(f)
	Alt. Harmonic Factor (Typical / Damage)	0dBm ± 3dB / 6 dBm	2.92mm(f)
RF Port	VDI Precision Flange	Contact VDI for Details	UG-387/U-M
IF Port	--	--	2.92mm(f)
DC Bias Voltage	For MixAMC-I Module (WR1.5, WR1.0)	+9V ± 0.1V / ~1A max	Solder Pin Connector
	For MixAMC-I Module (WR15 to WR2.2)	+5.5V ± 0.1V / ~1.75A max	
	For Fan*	+5V ± 0.1V / ~150mA max	28 AWG Bare Wire Leads
Maximum Case Temperature**		45°C	--
Maximum Weight		1.0 lbs.	--



### LO Drive Labels

Follow the LO input listed on MixAMC-I labels for optimal performance. Values shown here are only examples.



\*To reduce noise contributions from provided fan, VDI recommends operating the fan on a separate, isolated power supply.

\*\*MixAMC-I products are shipped with a heat sink and fan assembly to maintain case temperature below limit. The heatsink and fan assembly may be removed. If the heat sink and fan assembly is removed, user must provide sufficient heat sinking to keep unit below maximum case temperature specification.

Summary of Performance Specifications for Integrated Mixer / Amplifier / Multiplier Chains												
Waveguide Band	WR15	WR12	WR10	WR8.0	WR6.5	WR5.1	WR4.3	WR3.4	WM-710 (WR-2.8)	WM-570 (WR-2.2)	WM-380 (WR-1.5)	WM-250 (WR-1.0)
Start Frequency (GHz)	50	60	75	90	110	140	170	220	260	330	500	750
Stop Frequency (GHz)	75	90	110	140	170	220	260	330	400	500	750	1100
MixAMC-I-N SSB Conversion Loss (dB, typ.)**	10	10	10	10	10	11	11	12	13	14	18	25
MixAMC-I SSB Conversion Loss (dB, typ.)**	-2	-2	-2	-2	-2	-1	-1	0	1	2	6	13
Maximum Available IF Bandwidth (GHz)	7.5	9	11	14	17	22	26	40	40	40	40	40
Small Signal RF Input Power (~1dB Compression / Damage, dBm)	-10 / 0	-10 / 0	-10 / 0	-10 / 0	-10 / 0	-10 / 0	-10 / 0	-10 / 0	-10 / 0	-10 / 0	-10 / 0	-20 / -10
Standard LO Harmonic Factor	6	6	6	12	12	12	24	24	24	36	54	72
Alternative LO Harmonic Factor*	-	-	-	6	6	6	12	12	12	12	18	36

\*Alternative harmonic factors may be available upon request at no additional cost. Contact VDI for more information. Typical LO Input Power range may vary for alternative harmonic factor configurations. See individualized datasheet for actual input power range. Due to LO regeneration in the IF, VDI often recommends using lower (alternative) LO harmonic factors, if possible.

\*\*For MixAMC-I (configured with internal IF amplifier with ~12dB gain), intrinsic mixer conversion loss is estimated by adding 12dB to the MixAMC-I SSB Conversion Loss data. For MixAMC-I-N (configured without internal IF amplifier), the MixAMC-I-N SSB Conversion Loss is the intrinsic mixer conversion loss.

### General Notes:

- Standard configuration includes ~100kHz-40GHz IF amplifier, ~12dB gain. There is no direct access to mixer IF port.
- The user can choose to order the MixAMC-I without the IF amplifier. If the amplifier is removed, the IF port is extremely ESD sensitive. To choose this option, add -N to the name on the Purchase Order. For example, for WR10MixAMC-I with no IF amplifier, please specify WR10MixAMC-I-N on the Purchase Order.
- Intrinsic mixer conversion loss is measured at 322.5 MHz IF, loss increases at a rate of ~1.5dB/10 GHz up to the specified maximum IF.



The safety and operational guidelines are listed on page 4. VDI recommends the following general operating procedures for using these products with optimal performance.

### Required Operating Procedures

- DO NOT exceed damage limits listed in this manual and in individualized datasheets.
- Discharge static from cables before connecting to device. Use extreme ESD caution when connecting/disconnecting from the IF port.
- When soldering to DC Bias Voltage and Ground Connection pins, please follow Recommended Soldering Guidelines (see Page 4).

### Turn-On Procedure

- 1) The user and test bench must be properly grounded and protected against ESD.
- 2) With the Small Signal and LO input power turned OFF, make all necessary connections (i.e. LO cable, IF cable, voltage biases, etc.).
- 3) Apply appropriate voltage biases to MixAMC-I and provided fan (if used).
- 4) Turn on the LO input power
- 5) Turn on the small signal RF input power and monitor the output power.

### Turn-Off Procedure

- 1) The user and test bench must be properly grounded and protected against ESD.
- 2) Turn OFF the small signal RF input power.
- 3) Turn OFF the LO input power.
- 4) Replace IF port with provided 50 $\Omega$  termination when IF port is disconnected from user system. For MixAMC-I-N, the IF port is extremely ESD sensitive.
- 5) Turn 'OFF' voltage biases to MixAMC-I and provided fan (if used).
- 6) It is now safe to turn OFF and/or disconnect all other equipment on user test bench.

### Guidelines for Block Down-Conversion

- Attenuation between the MixAMC-I module and user spectrum analyzer (or similar instrument) may be necessary to avoid saturation or damage of the instrument. Refer to saturation and damage limits in manufacturer's operating manual.
- The input LO frequency should be greater than the maximum IF frequency used, in order to prevent regeneration of the LO signal (and harmonics of the LO signal) in the IF Output.
- If possible, VDI recommends configuring the MixAMC-I with the lowest harmonic factor option to reduce spurious signals in the IF Output Port.

Typical SSB Intrinsic Mixer Conversion Loss plots are provided on the following pages, starting with WR15 (50-75 GHz) and ending with WR1.0 (750-1100 GHz) on Page 15. Conversion Loss data shown below assumes IF ~ 322.5 MHz. Some MixAMC-I-N data shown below is calculated from MixAMC-I data, assuming 12dB gain from the IF amplifier inside the MixAMC-I.

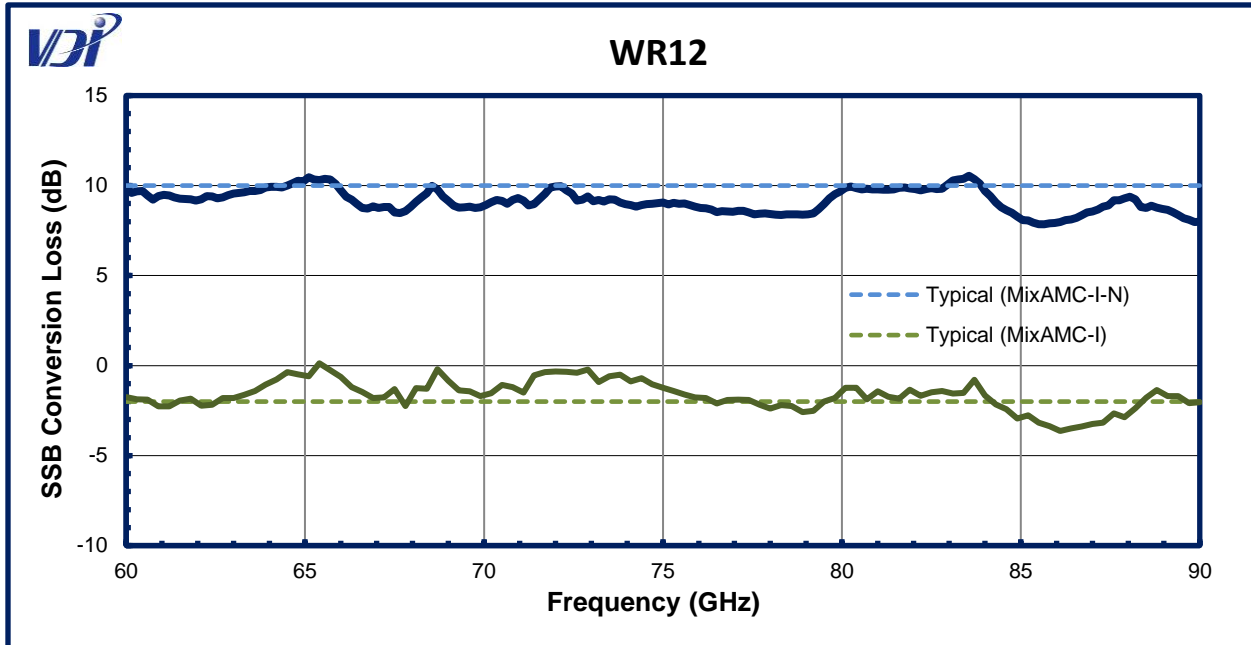
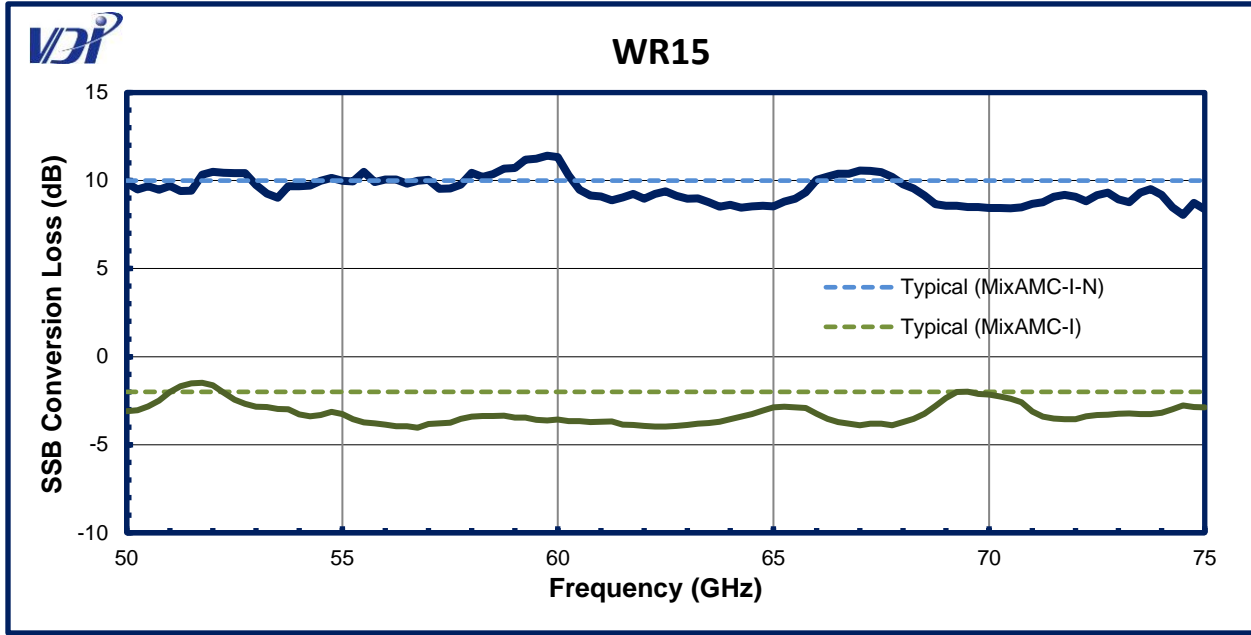

# MixAMC-I SSB Conversion Loss - continued

## MixAMC-I Performance — Continued

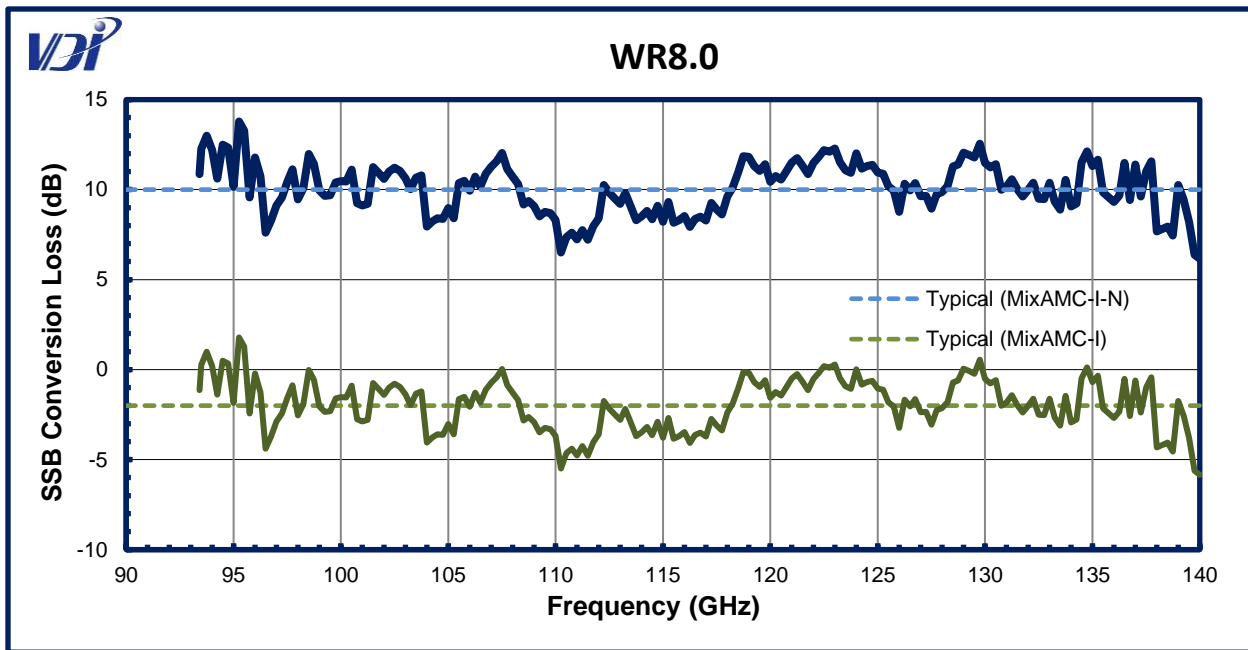
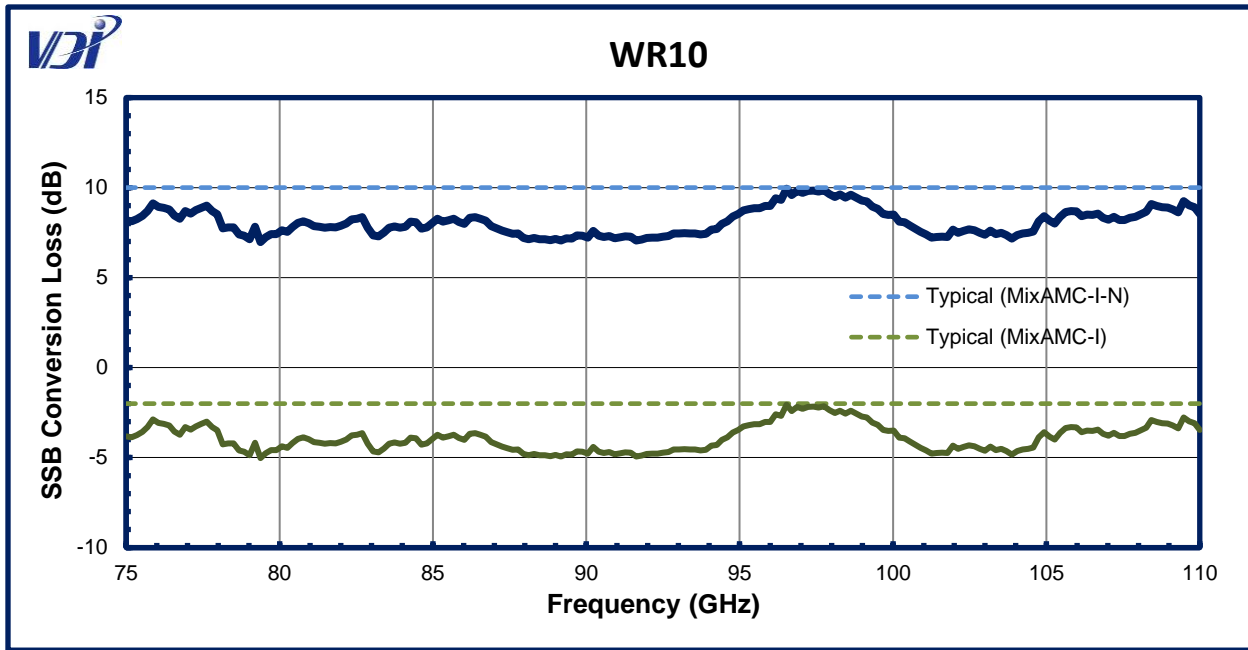

# MixAMC-I SSB Conversion Loss - continued

## MixAMC-I Performance — Continued

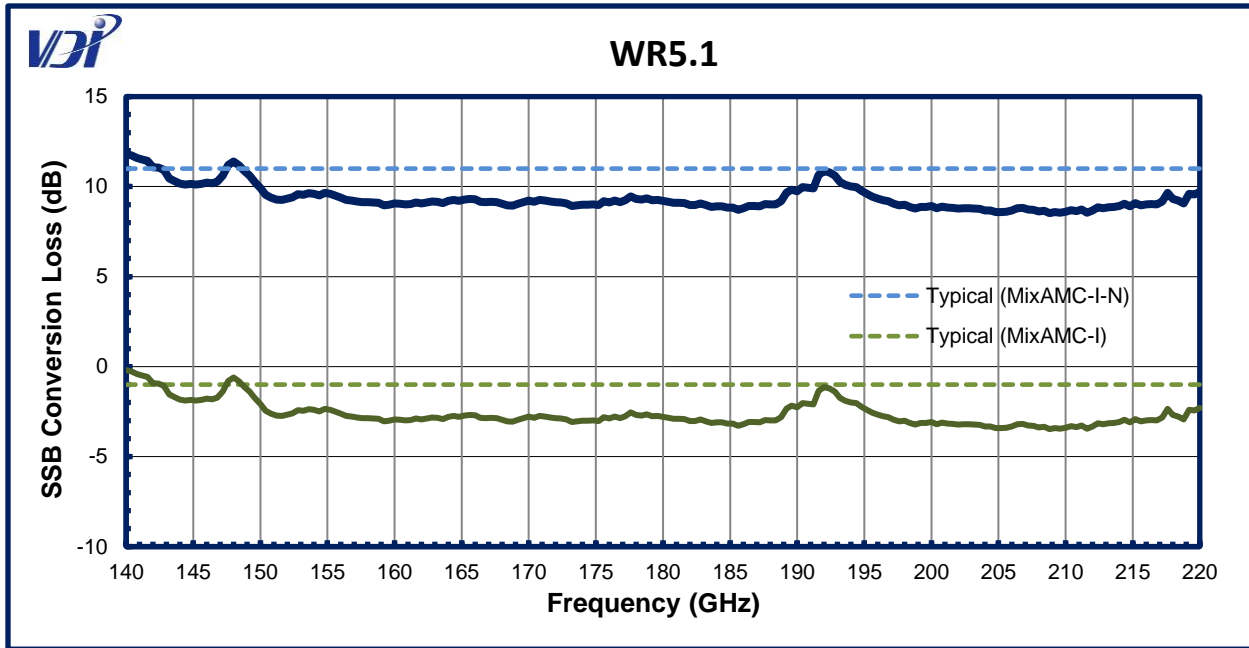
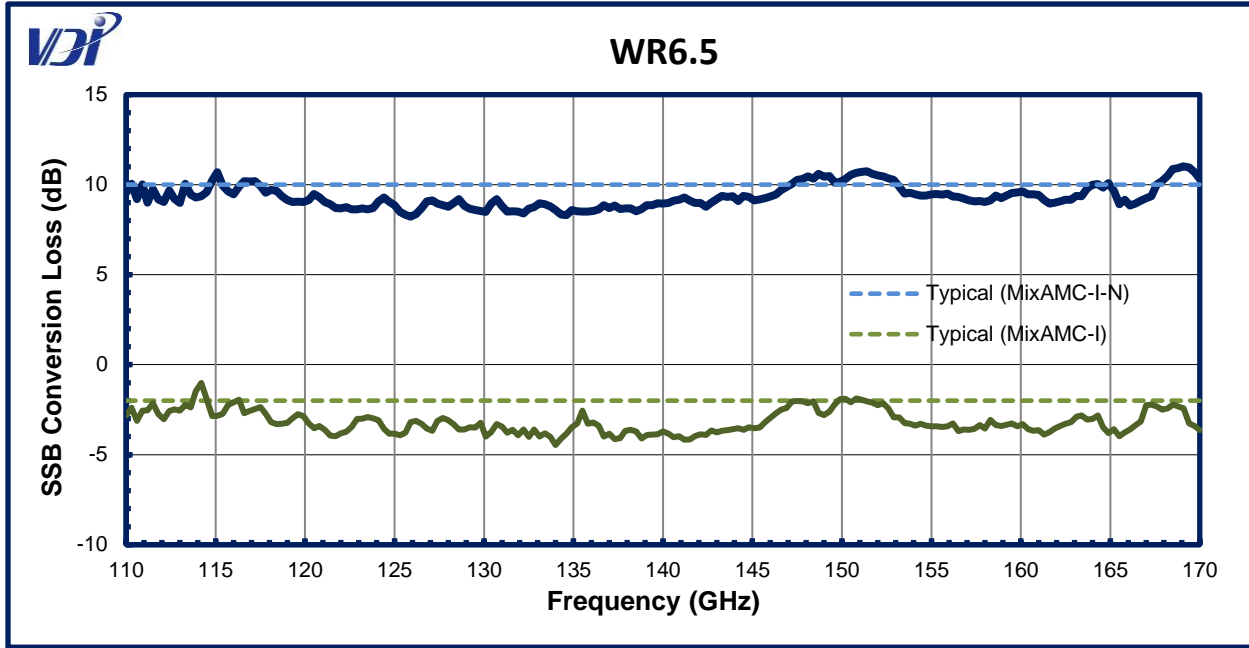

# MixAMC-I SSB Conversion Loss - continued

## MixAMC-I Performance — Continued

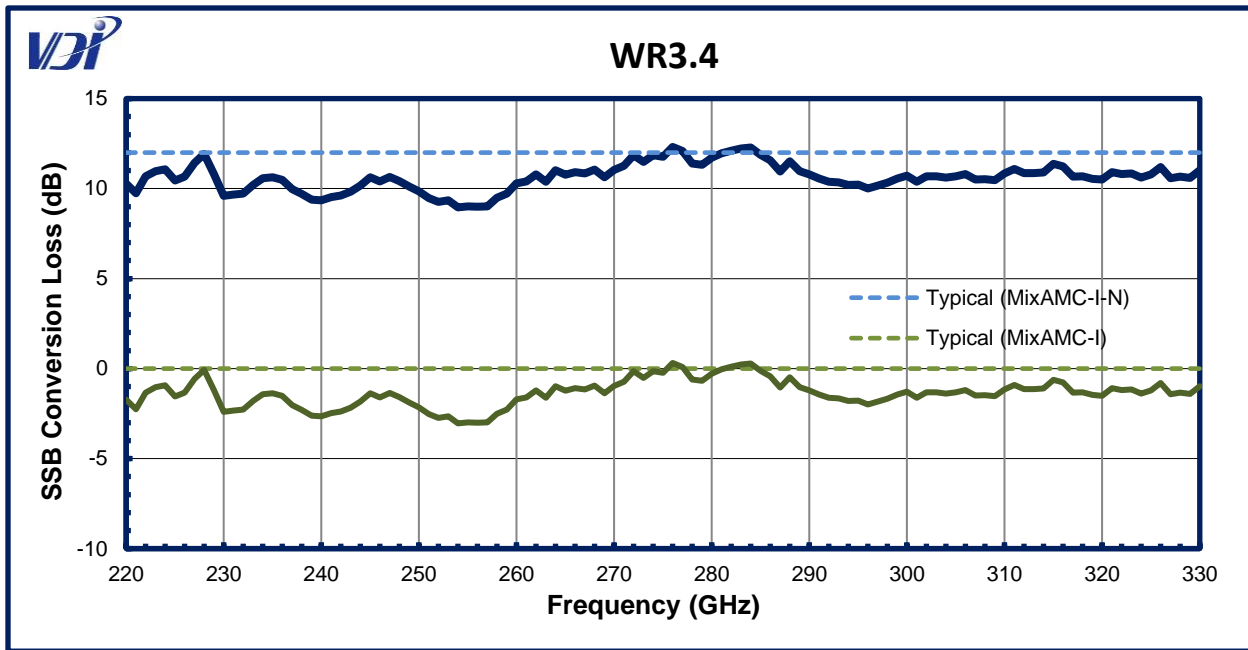
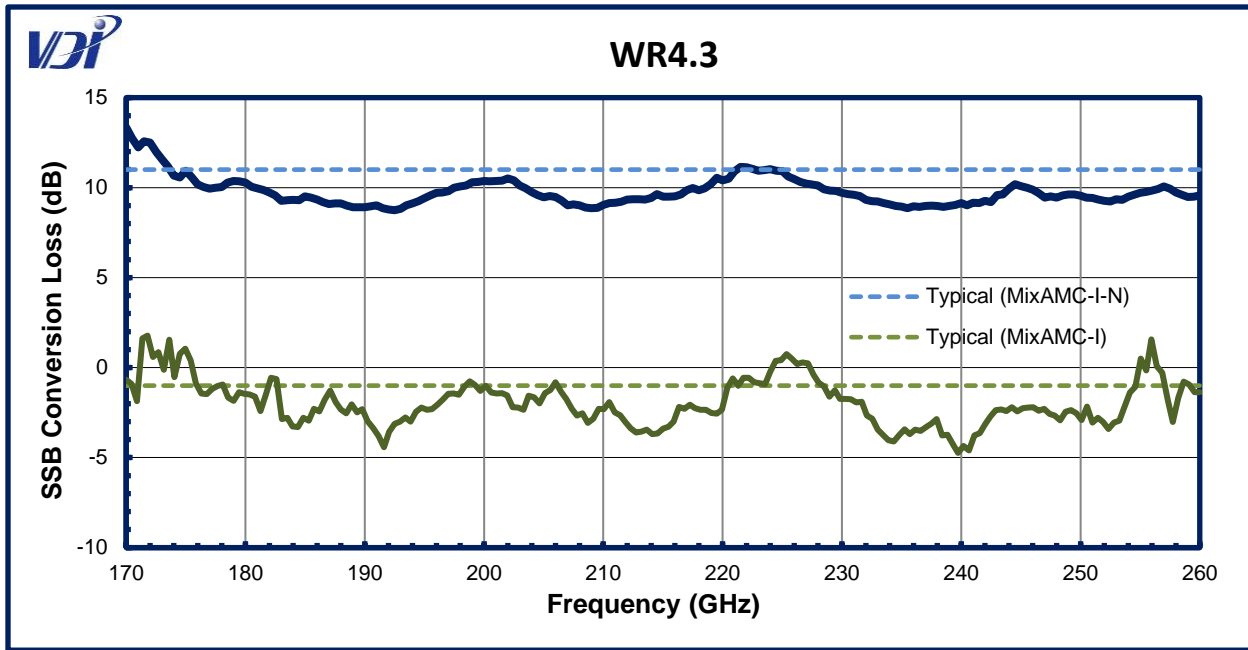

# MixAMC-I SSB Conversion Loss - continued

## MixAMC-I Performance — Continued

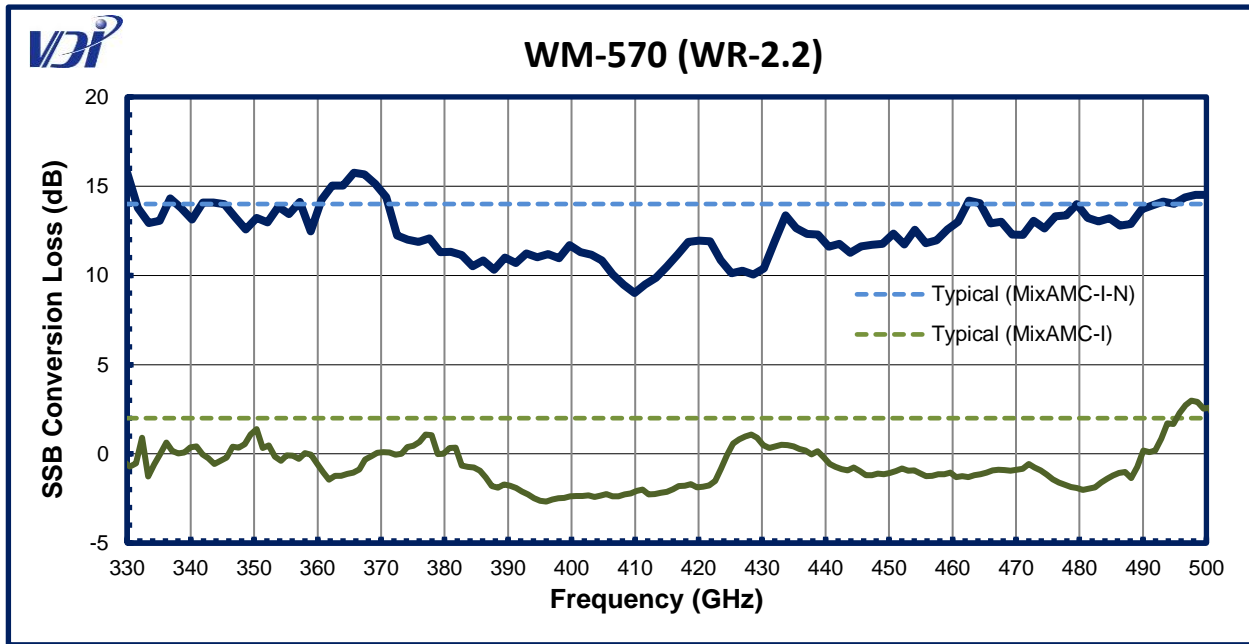
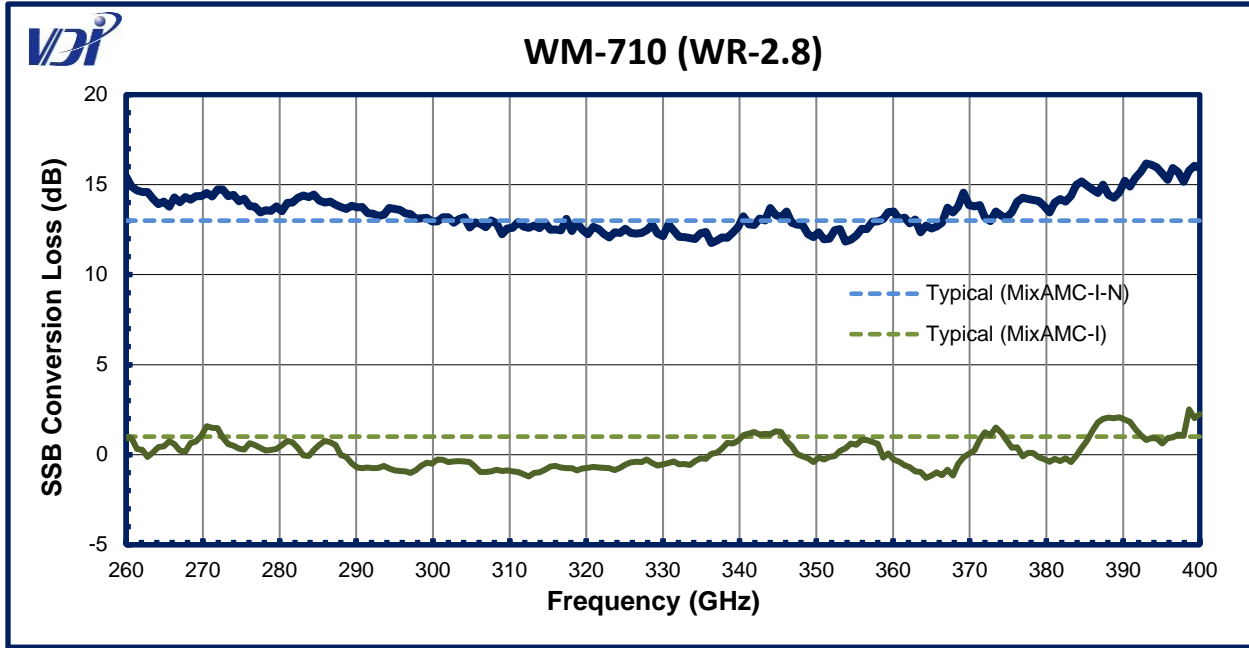



# MixAMC-I SSB Conversion Loss - continued

## MixAMC-I Performance — Continued

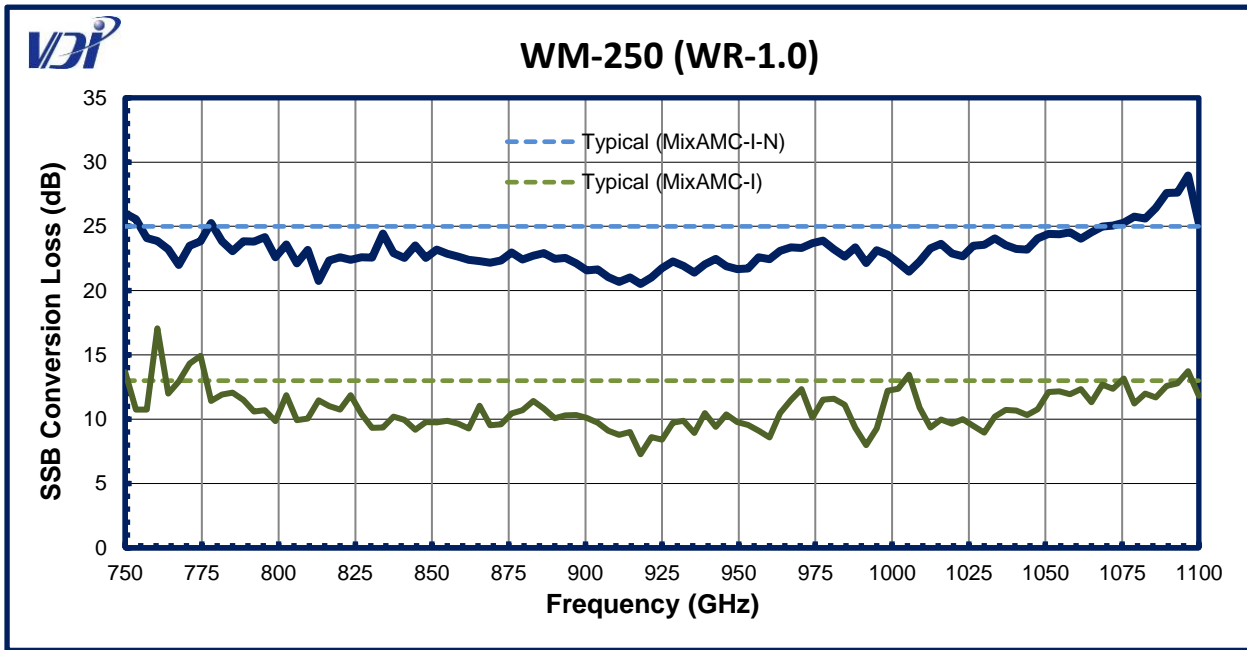
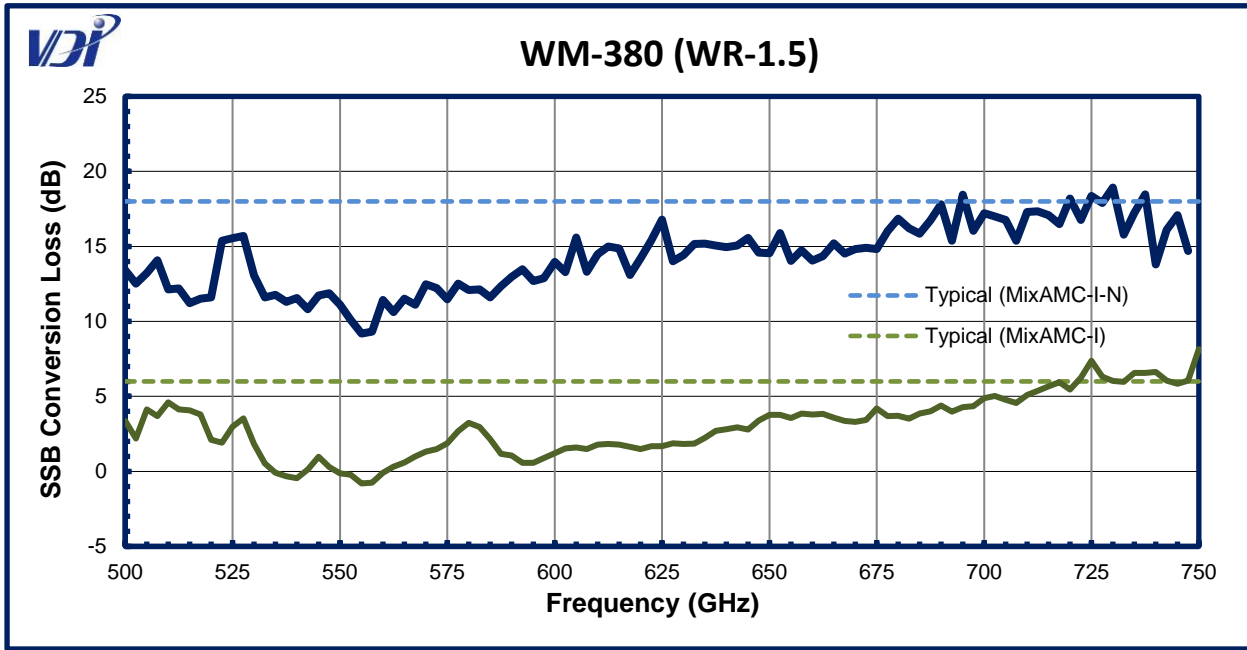

## Conversion Loss vs. IF Frequency

Note: The SSB conversion loss specification listed on Page 8 is specified at an IF of 322.5 MHz. The conversion loss increases with increasing IF frequency at a rate of ~2dB per 10 GHz. The data below shows SSB Conversion Loss of a WR2.8MixAMC-I-N with an LO centered at 310 GHz and an RF source sweeping from 310 to 350 GHz. The data presented in this graph was measured by VDI under specific test conditions. The exact shape of the curves will vary significantly depending on the measurement conditions, including operating temperature, load impedance, LO frequency, RF frequency, etc. The performance is also unique to the frequency band and specific serial number of the module.

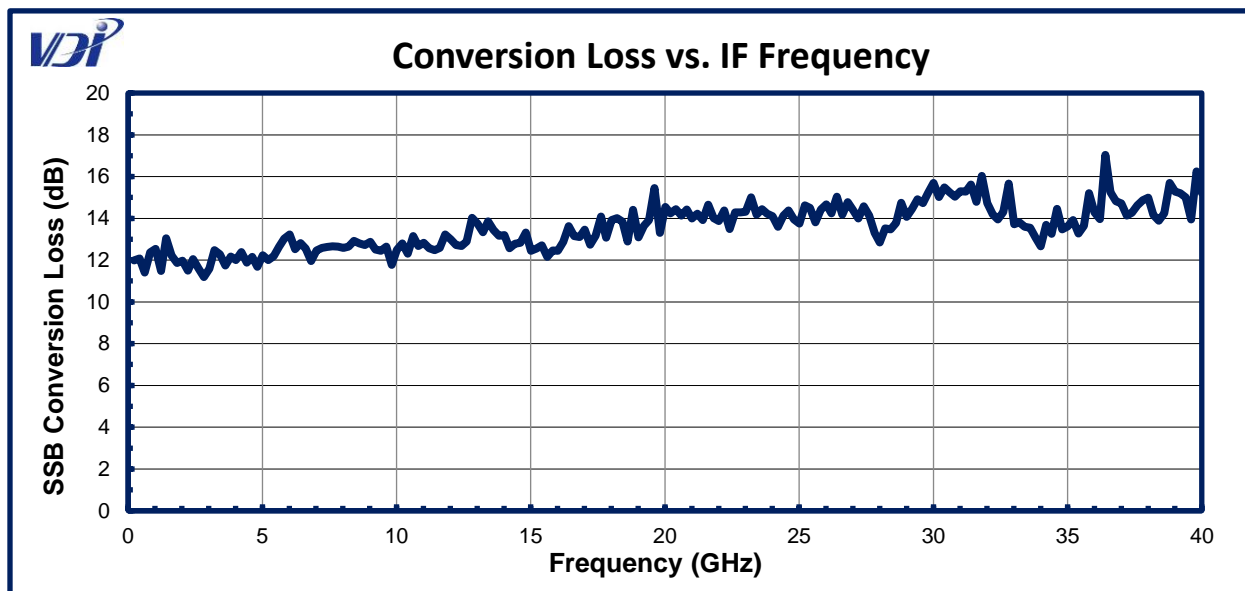

Part Number:

**WRXX**Mix**AMC-I-N-MFF**

**Waveguide Band:**

Examples:

**WR15** for 50-75 GHz

**WR1.0** for 750-1100 GHz

**IF Amplifier Option:**

Include **-N** to configure without IF Amplifier

Remove **-N** to configure with IF Amplifier

Alternative Harmonic Factor Option (See Page 8 for Alternative Harmonic Factor Options):

Replace **FF** with Alternative Harmonic Factor

**Examples:**

**WR6.5MixAMC-I:** 110-170 GHz Integrated Mixer / Amplifier / Multiplier Chain, with standard LO harmonic factor (N=12), with integrated IF amplifier

**WR6.5MixAMC-I-N:** 110-170 GHz Integrated Mixer / Amplifier / Multiplier Chain, with standard LO harmonic factor (N=12), without IF amplifier. IF port is extremely ESD sensitive

**WR6.5MixAMC-I-M6:** 110-170 GHz Integrated Mixer / Amplifier / Multiplier Chain, with alternative LO harmonic factor of N=6, with integrated IF amplifier

**WR6.5MixAMC-I-N-M6:** 110-170 GHz Integrated Mixer / Amplifier / Multiplier Chain, with alternative LO harmonic factor of N=6, without IF amplifier. IF port is extremely ESD sensitive

# Addendum — Product Updates and Company Contacts

The Virginia Diodes staff of engineering and physical science professionals works to continually improve our products. We also depend upon feedback from colleagues and customers. Ideas to simplify operations, improve performance or add capabilities are always welcome.

## Contact VDI:

### Virginia Diodes, Inc.

Web: <http://www.vadiodes.com>

Email: [Technical@vadiodes.com](mailto:Technical@vadiodes.com)

Telephone: 434.297.3257