

Integrated Amplifier / Multiplier Chain Operational Manual



979 Second Street SE, Suite 309
Charlottesville, VA 22902-6172 (USA)
Tel: 434.297.3257; Fax: 434.297.3258
www.vadiodes.com

Contents

Section 1 – Introduction	Pages 2-4
Contents	Page 2
AMC-I General Overview	Page 3
Safety and Operational Guidelines	Page 4
Section 2 – Product Views, Block Diagrams and Specifications	Pages 5-7
Product Overview	Page 5
Module Details – Front and Rear Panel Connections, Block Diagram	Page 6
General Specifications and Technical Notes	Page 7
Section 3 – Operational Procedures	Page 8
General Operating Procedures	Page 8
Appendix 1 – AMC-I Test Port Power	Pages 9-16
AMC-I Test Port Power	Page 9-16
Appendix 2 – User Controlled Attenuation	Page 17
User Controlled Attenuation (UCA) Performance	Page 17
Addendum – Product Updates and Company Contacts	Page 18

AMC-I General Overview

Integrated Amplifier / Multiplier Chains

Virginia Diodes' integrated amplifier / multiplier chains are used to extend the performance of microwave signal generators in the frequency range from 50 GHz through 1.1 THz, in frequency bands from WR15 (50-75 GHz) to WR1.0 (750-1,100 GHz). These modules offer high test port power with full waveguide band coverage in a compact package. Standard features include TTL controlled ON/OFF modulation up to ~ kHz and voltage controlled RF attenuation.

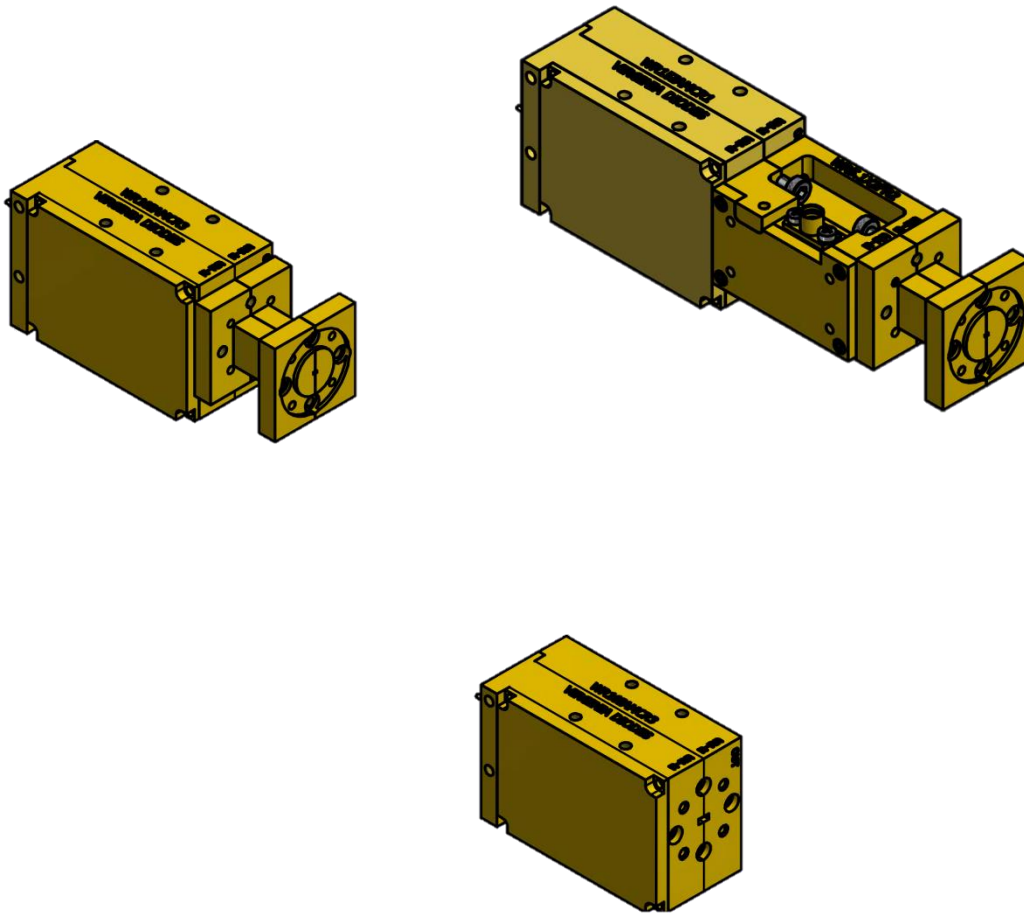

Safety and Operational Guidelines

 Read all instructions and information in this product manual before connecting a module to its power supply or a signal generator. Operational procedures must be followed for proper function. If you have questions, contact VDI before supplying power to or otherwise operating any VDI module.

 VDI assumes the customer is familiar with microwave, millimeter wave and VDI products in general. The user and customer are expected to understand all safety guidelines, health hazards and general advisories that may exist and are associated with the use of this device. VDI is not responsible for any human hazards that may exist or may occur while using this device.

RF Drive Limitations

 Recommended RF input power specifications are noted on the label on every VDI module. See example on Page 7; these values provide optimal performance. Irreversible damage can result if input power exceeds stated damage threshold.

Virginia Diodes, Inc. (VDI) accepts no liability for damage or injury resulting from or caused by:

- Improper operation, disassembly or use for purposes other than those for which the module was designed.
- Use outside common safety, health or general advisories pertaining to microwave, millimeter wave and VDI products
- Repairs carried out by persons other than VDI or its assigned agents.

Waveguide Inspection / Test Port Care

- Inspect waveguide flanges prior to making connections.
- Waveguide screws should be torqued in the range 20-50 cNm, greater torque can damage the interface.
- Making a connection with metal debris between the waveguide flanges can damage the waveguide interface and prevent repeatable connections.
- If debris is present, clean the flange with pre-dampened TexWipe wipes or swabs (e.g. Part Number TX1065).
- If these are not available, TexWipe cloths lightly dampened with ethanol may be used (e.g. Part Number TX604).
- Replace dust caps when the system is idle.

General Operating Practices and Recommendations

- VDI AMC-I modules are intended to be used in typical laboratory conditions.
- Use of any attachments and accessories not authorized by VDI or that do not meet VDI's specifications may void a module's limited warranty and could pose a hazard to the operator or cause lasting damage to the device.
- Disassembling a module can cause lasting damage to components and pose a hazard to the operator.
- Applying liquids (other than the TexWipe wipes/cloths used for cleaning) can cause lasting damage to the module.
- VDI does not recommend the use of liquids or paste for either thermal grounding of VDI components or for locking screws. Liquids/pastes wicking into the VDI component can damage the internal devices and worsen device performance.
- Check with VDI before any measurement connection is attempted beyond those described in this manual or if it may exceed commonly accepted standards of practice.
- Use a torque of 90 cNm when making coaxial connections. Avoid sharp bends in cables.

Recommended Soldering Guidelines

- Follow manufacturer's recommendations where applicable.
- Do not put any rotational stress on the solder pin.
- Use a temperature-controlled soldering iron with a wedge tip set for 275°C. Dwell time for soldering should be no longer than 5 seconds. To avoid cold solder joints, the dwell time may be extended to 7 seconds safely when using a heat sink clamp on the solder pins. Also, the iron temperature may be increased to no more than 295°C for 5 seconds with the use of a heat sink clamp.
- Allow the solder to cool naturally. Clean the flux from the solder joint only after the pin and filter body have cooled to room temperature.
- Use wire gauge between 22AWG and 24AWG.
- Use Sn60/Pb40, Sn63/Pb37, Sn62/Pb36/Ag2, or Sn96.5/Ag3/Cu0.5 0.38mm solders.
- Place a small heat sink clamp between the filter body and wire attachment location whenever possible.

Typical AMC-I modules are shown. The exact equipment delivered may vary.

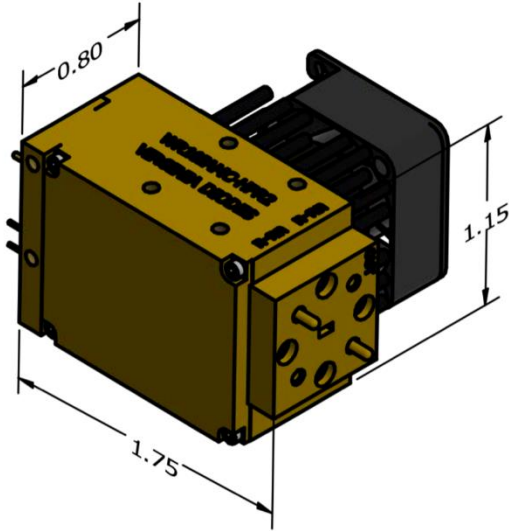

WR15, WR12, WR10, WR9.0, WR8.0, WR6.5

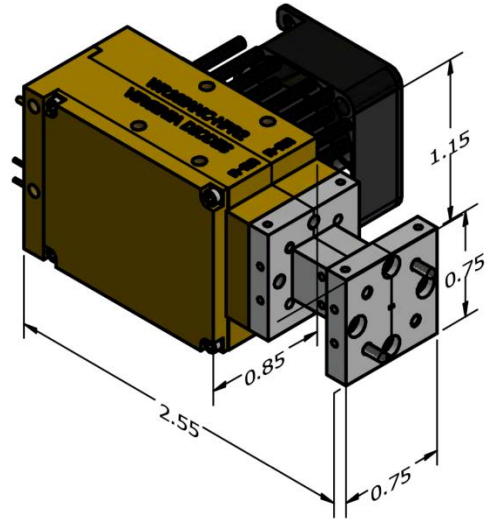

WR3.4, WR2.8, WR2.2, WR1.0

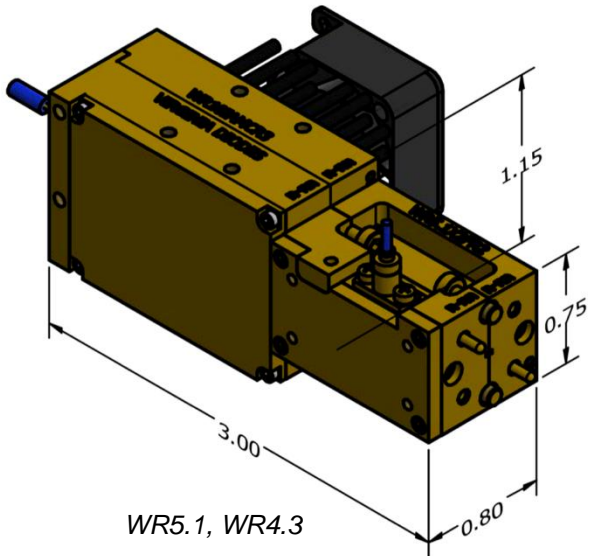

WR5.1, WR4.3

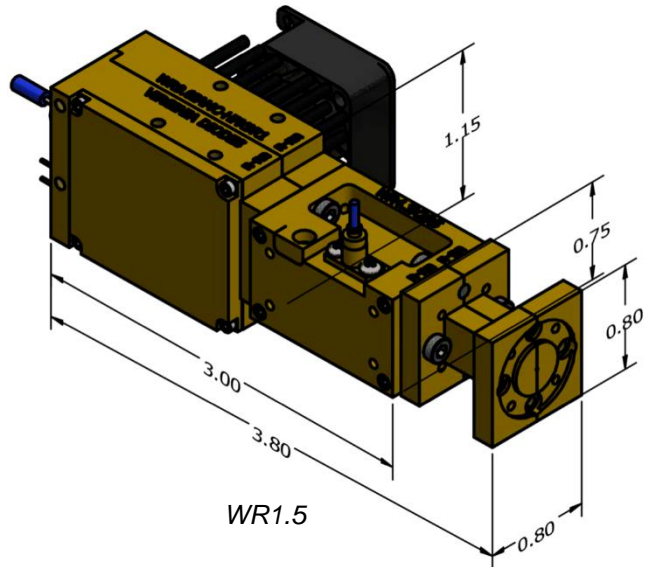

WR1.5

Dimension Units: Inches

Front and Rear Panel Connections, Block Diagram

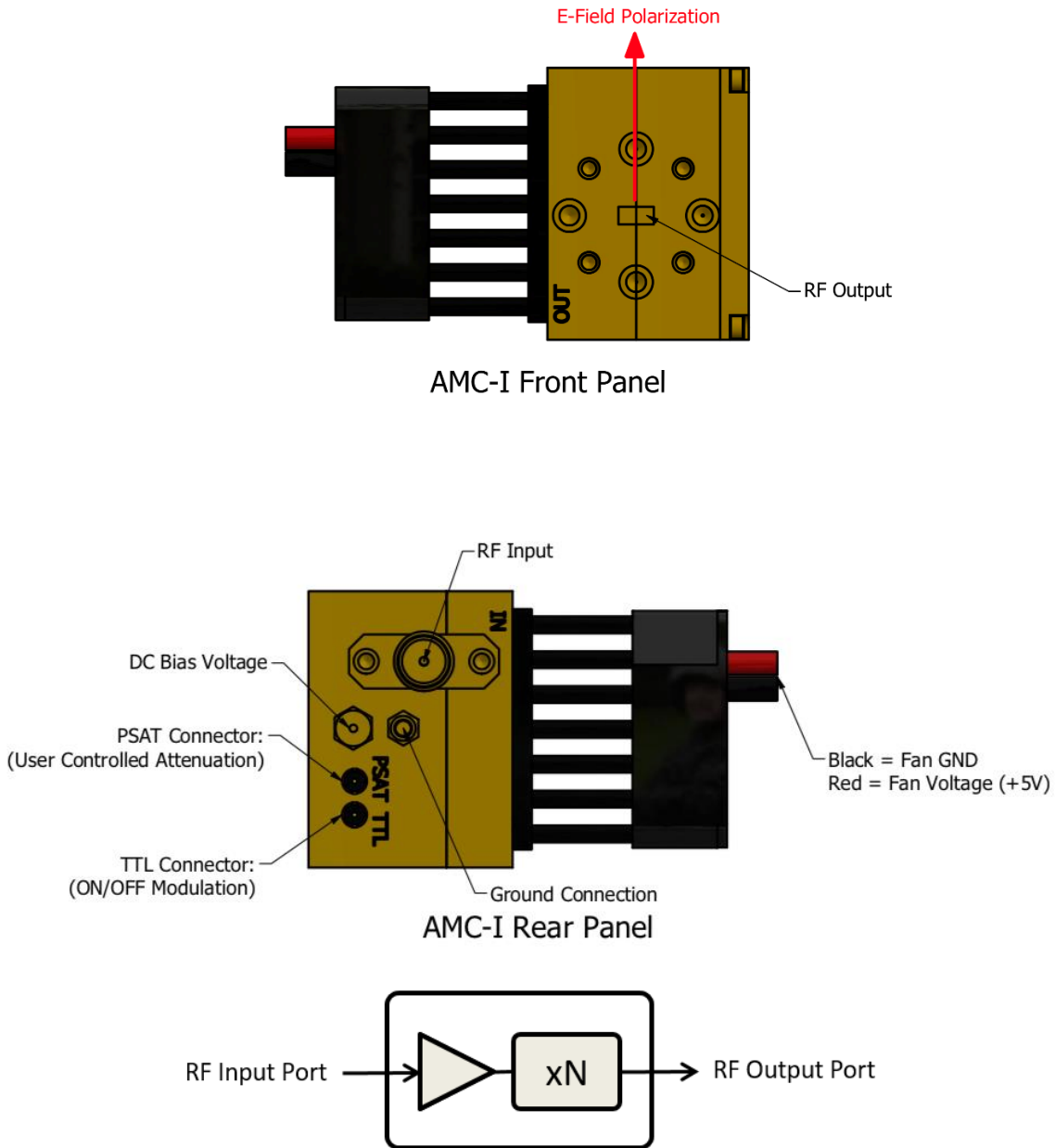

Figure 1: AMC-I Block Diagram

Simplified block diagram for a typical AMC-I module is shown. Location of power amplifiers and multipliers vary for each unit. N is the multiplication factor for this configuration.

Please refer to Page 4 for VDI Recommended Soldering Guidelines. Please follow appropriate guidelines when soldering to DC Bias Voltage and Ground Connection pins.

General Specifications and Technical Notes

General Specifications Integrated Amplifier / Multiplier Chains			
Description		Specification	Connector
RF Input	Typical / Damage	0 dBm ± 3dB / 6 dBm	2.92mm(f)
RF Output	VDI Precision Flange	Contact VDI for Details	UG-387/U-M†
DC Bias Voltage	For AMC-I Module	+9V ± 0.1V (+15V damage) / ~1.5A max	Solder Pin Connector
	For Fan*	+5V ± 0.1V / ~150mA max	28 AWG Bare Wire Leads
TTL Connector**	TTL / AM Input (ON / OFF)	~0 = OFF, ~5 V = ON, up to ~kHz	Solder Pin Connector
PSAT Connector (RF Power Control)**	User Controlled Attenuation (UCA)	5V-full power, 0V-off (See Appendix 2)	Solder Pin Connector
Maximum Case Temperature		45°C	--
Maximum Weight		1.0 lbs.	--

RF
N=18
0dBm

RF Drive Labels

Follow the RF input listed on AMC-I labels for optimal performance. Values shown here are only examples.



*To reduce noise contributions from provided fan, VDI recommends operating the fan on a separate, isolated power supply.

**PSAT and TTL Connectors will default to +5V with no connection and result in full output power from the AMC-I module.

Summary of Performance Specifications for Integrated Amplifier / Multiplier Chains																
Waveguide Band	WR15	WR12	WR10	WR9.0	WR8.0	WR6.5	WR5.1	WR4.5	WR4.3	WR3.4	WR3.0	WM710 (WR2.8)	WM570 (WR2.2)	WR2.0	WM380 (WR1.5)	WM250 (WR1.0)
Start Frequency (GHz)	50	60	75	82	90	110	140	165	170	220	250	260	330	400	500	750
Stop Frequency (GHz)	75	90	110	125	140	170	220	250	260	330	375	400	500	550	750	1100
Output Power (dBm, typ.)	20	20	20	20	19	18	10	10	8	6	5	5	0	1	-7	-16
Output Power (dBm, min.)	17	17	17	17	13	15	6	5	3	3	0	-1	-6	-5	-13	-26
Standard Multiplication Factor	6	6	6	9	12	12	12	18	18	18	27	27	36	36	54	81
Alternative Multiplication Factor*	3	3	3	3	6	6	6	6	6	9	9	9	18	18	18	27

*Alternative multiplication factors may be available upon request at no additional cost. Contact VDI for more information.

General Notes:

- Power supply or mounting plate is not provided.
- AMC-I products are shipped with a removable heat sink and fan. If heat sink and fan are removed, the user must provide sufficient heat sinking to stay below maximum case temperature specification.
- Unwanted harmonic content is better than -20dBc typical.
- Higher frequency input (lower multiplication factor) reduces unwanted harmonic signals within the band and is preferred.
- AMC-I modules can be driven by any signal generator that supplies the required frequency band and power.
- Stability of the input is degraded by the harmonic factor N and phase noise by 20log(N).

The safety and operational guidelines are listed on page 4. VDI recommends the following general operating procedures for using these products with optimal performance.

Required Operating Procedures

- DO NOT exceed damage limits listed in this manual and in individualized datasheets.
- Discharge static from cables before connecting to device.
- When soldering to DC Bias Voltage and Ground Connection pins, please follow Recommended Soldering Guidelines (see Page 4).

Turn-On Procedure

- 1) With the RF input power turned 'OFF', make all necessary connections (i.e. RF cable, voltage biases, etc.).
- 2) Apply appropriate voltage biases to AMC-I and provided fan (if used).
- 3) Set signal generator to desired frequency and appropriate power level.
- 4) Turn 'ON' the RF input power from signal generator.
 - a. For Amplitude Modulation (ON/OFF): use TTL Port
 - b. For RF Attenuation: use PSAT Port

Turn-Off Procedure

- 1) Turn 'OFF' the RF input power from signal generator.
- 2) Turn 'OFF' voltage biases to AMC-I and provided fan (if used).
- 3) It is now safe to turn 'OFF' and/or disconnect all other equipment on user test bench.

Typical Test Port Power plots are provided on the following pages, starting with WR15 (50-75 GHz) and ending with WR1.0 (750-1100 GHz) on Page 16.

AMC-I Test Port Power

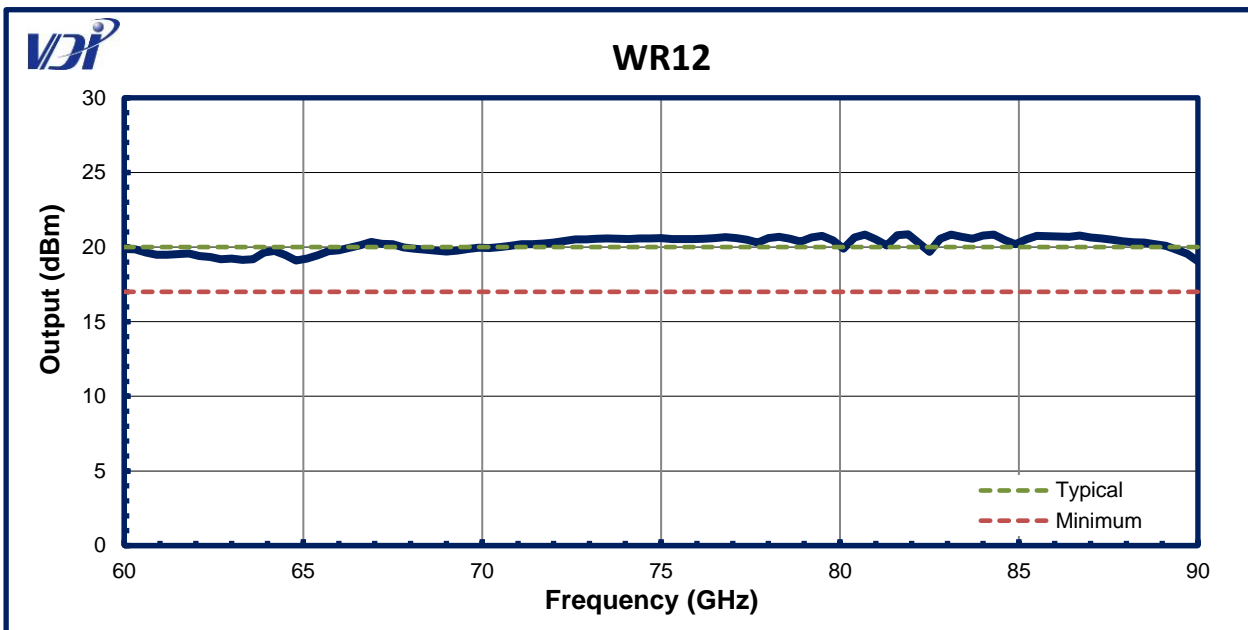
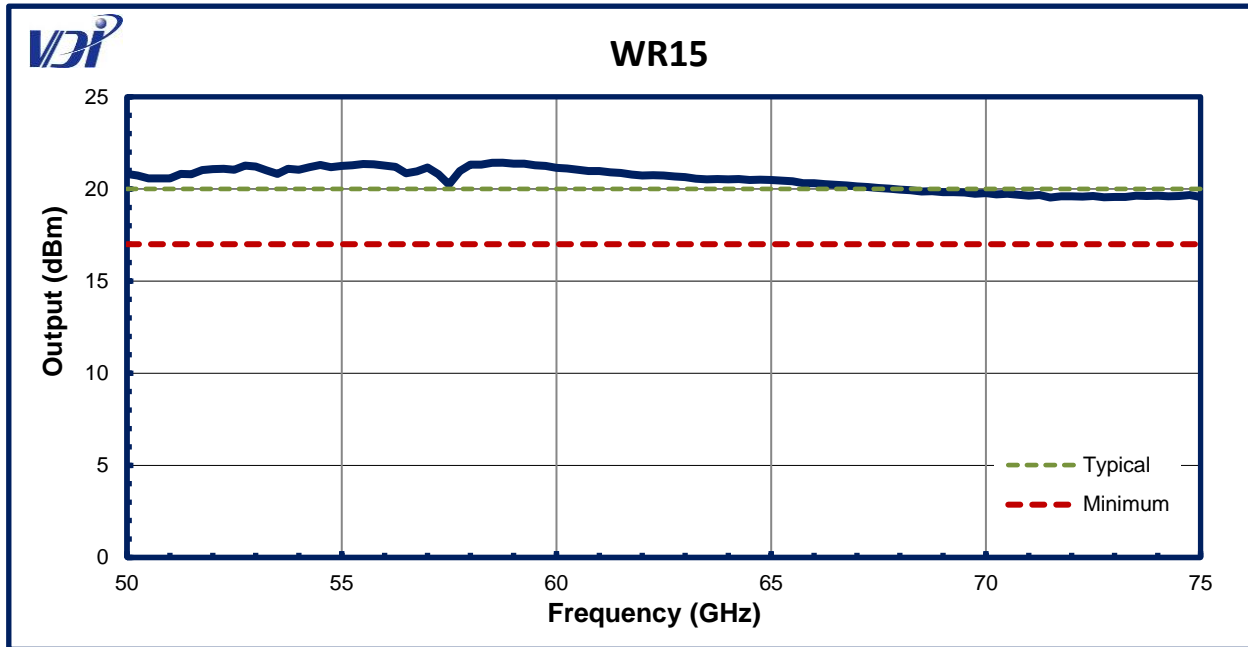

Test Port Power - continued

AMC-I Performance — Continued

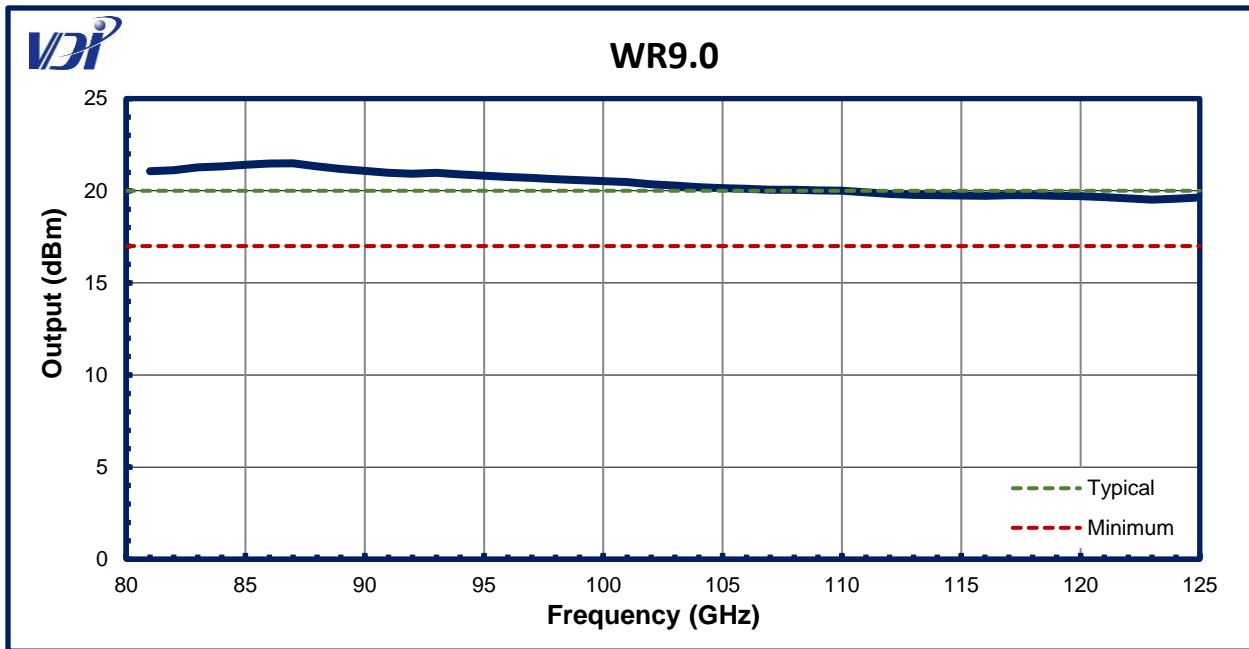
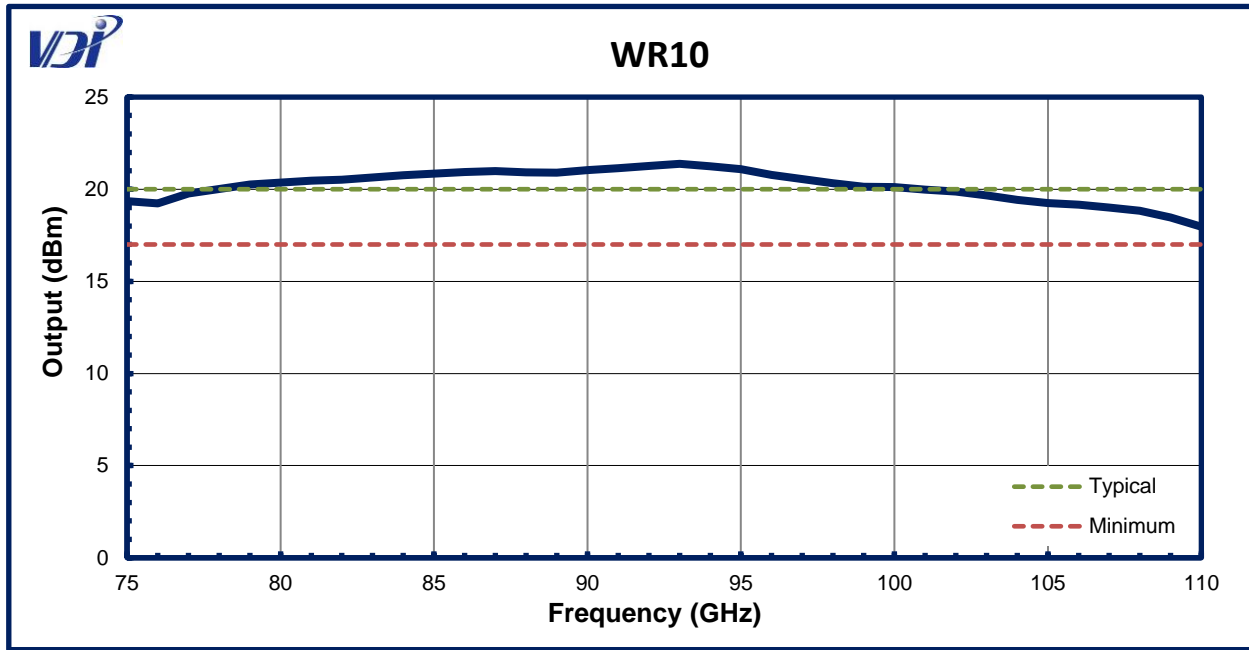

Test Port Power - continued

AMC-I Performance — Continued

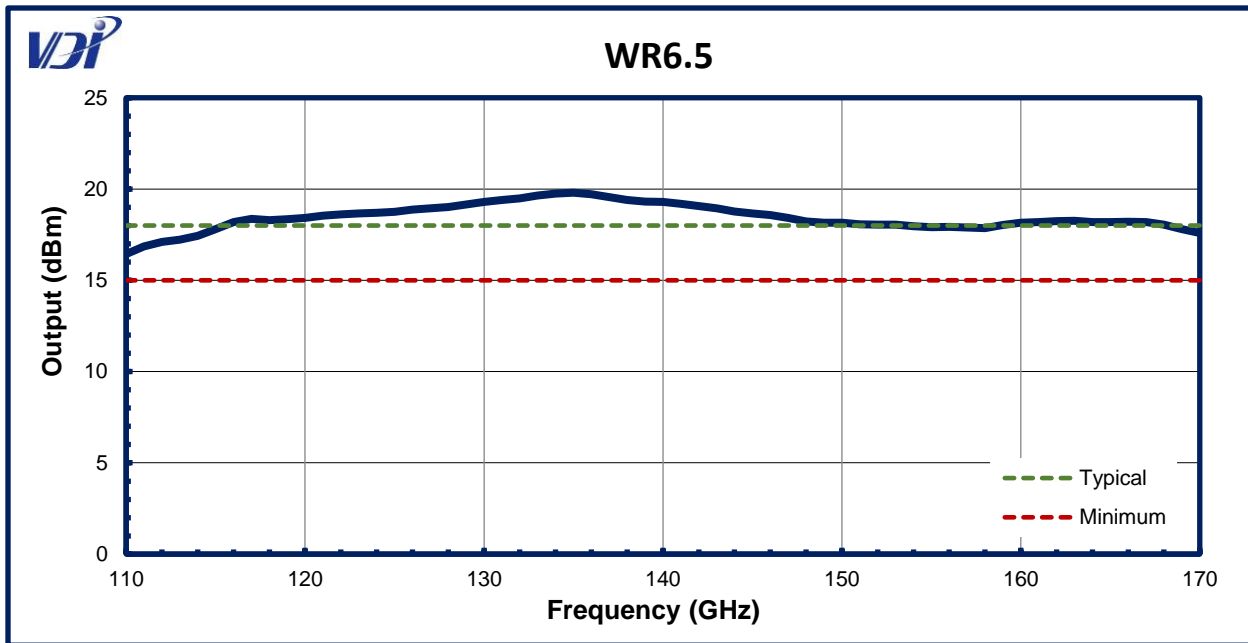
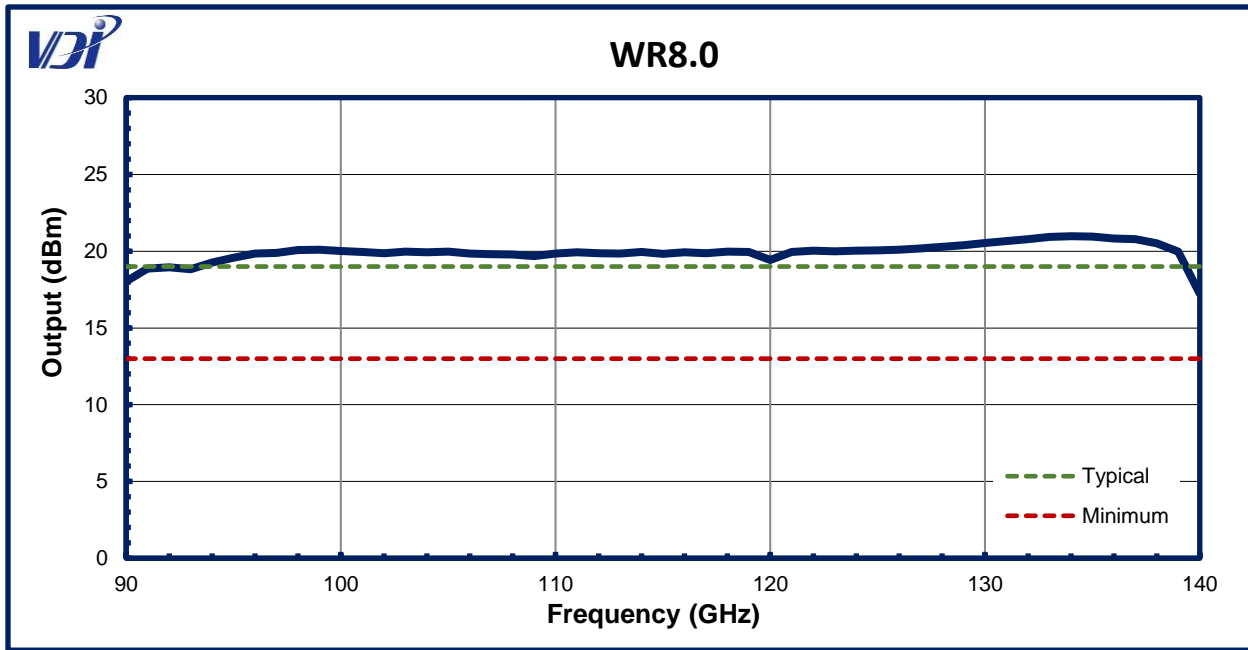

Test Port Power - continued

AMC-I Performance — Continued

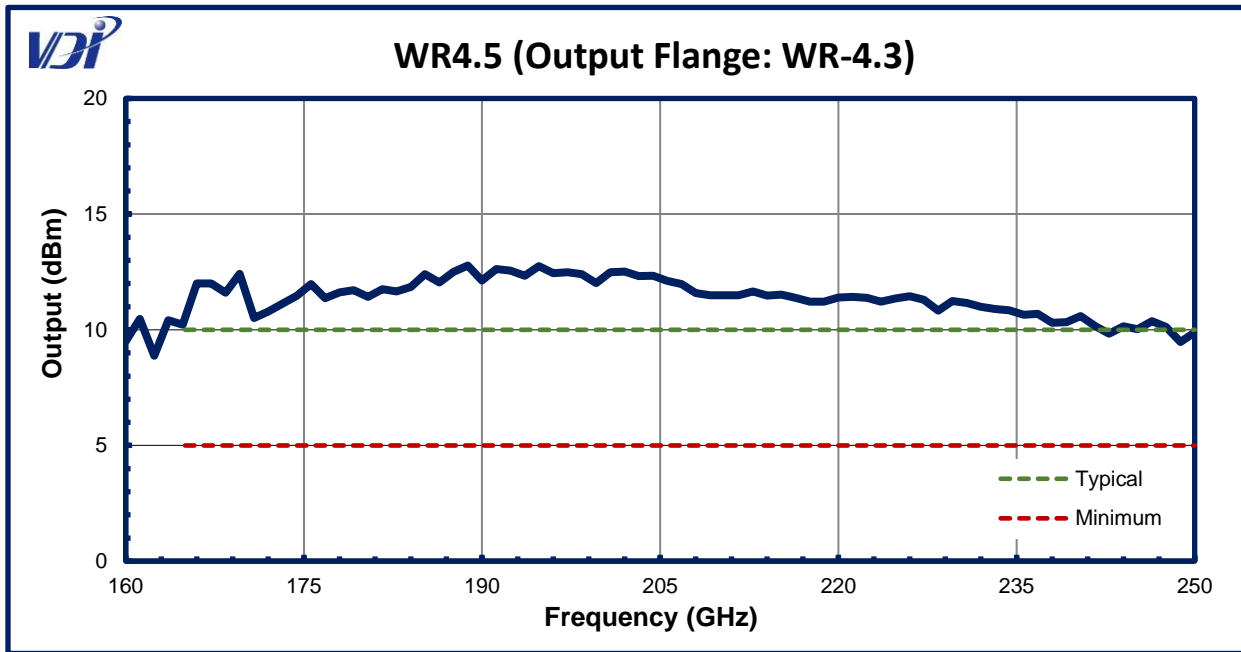
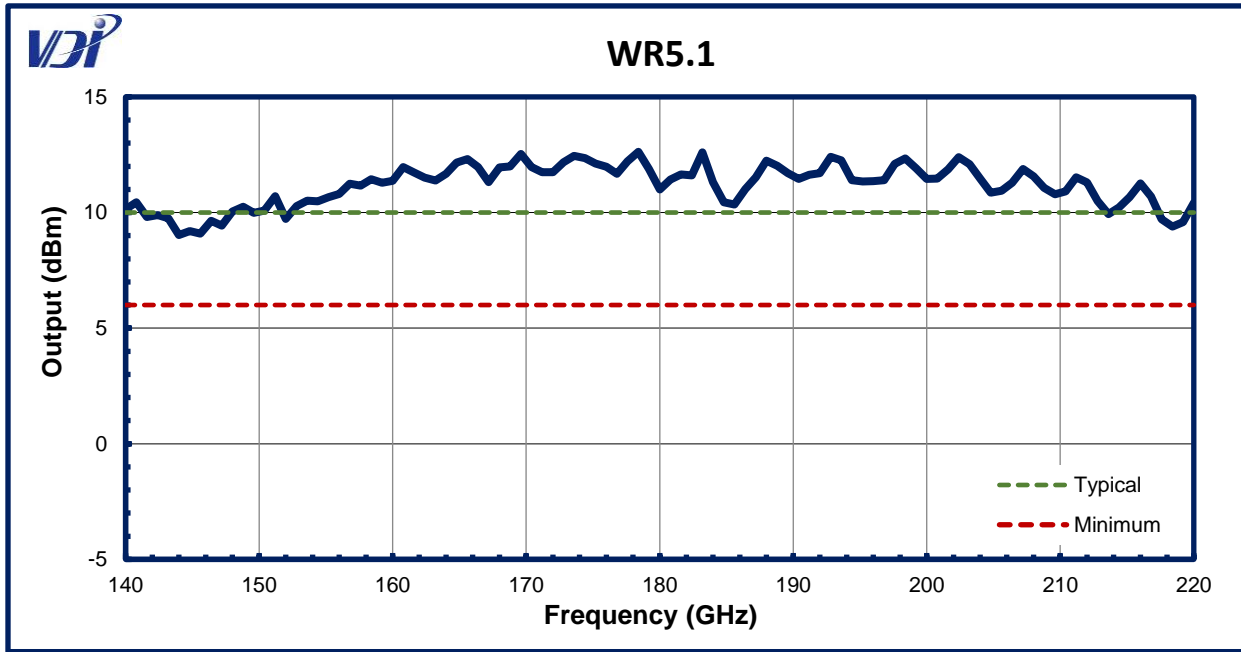

Test Port Power - continued

AMC-I Performance — Continued

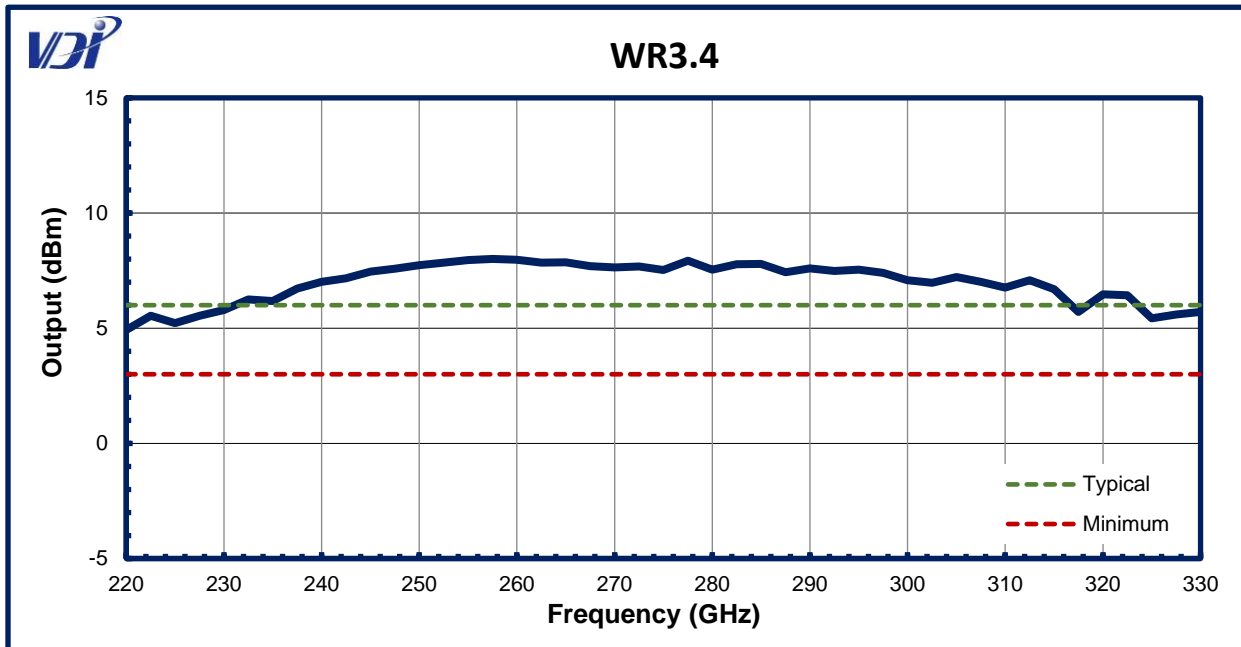
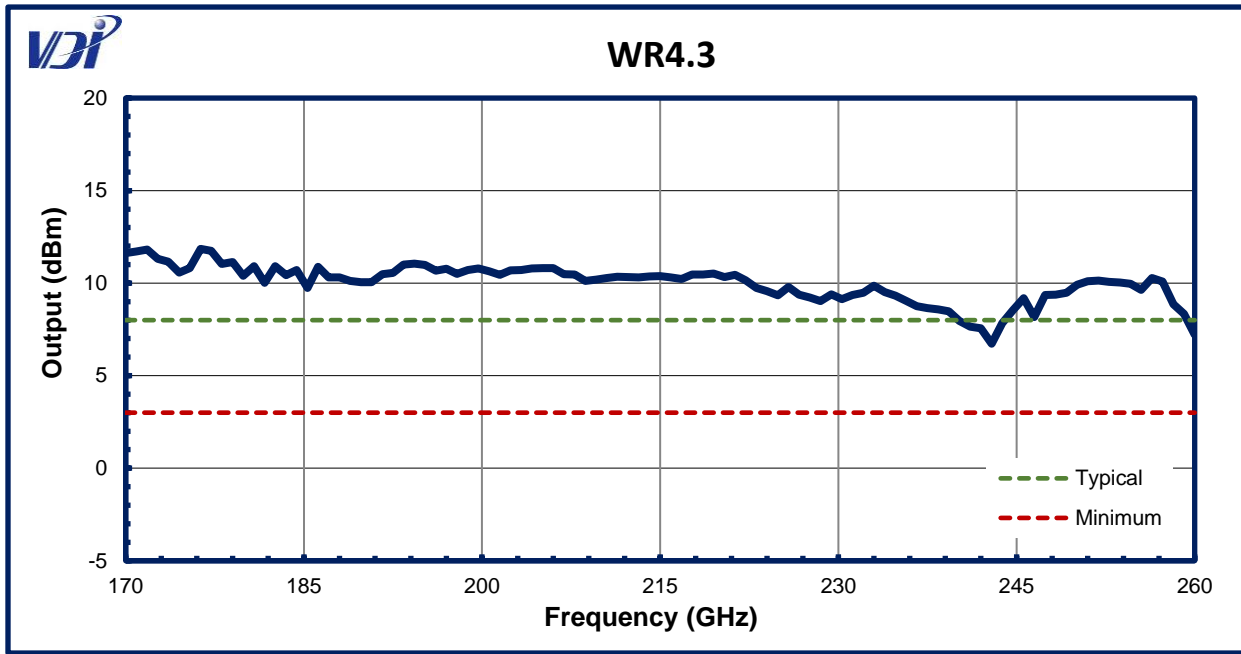

Test Port Power - continued

AMC-I Performance — Continued

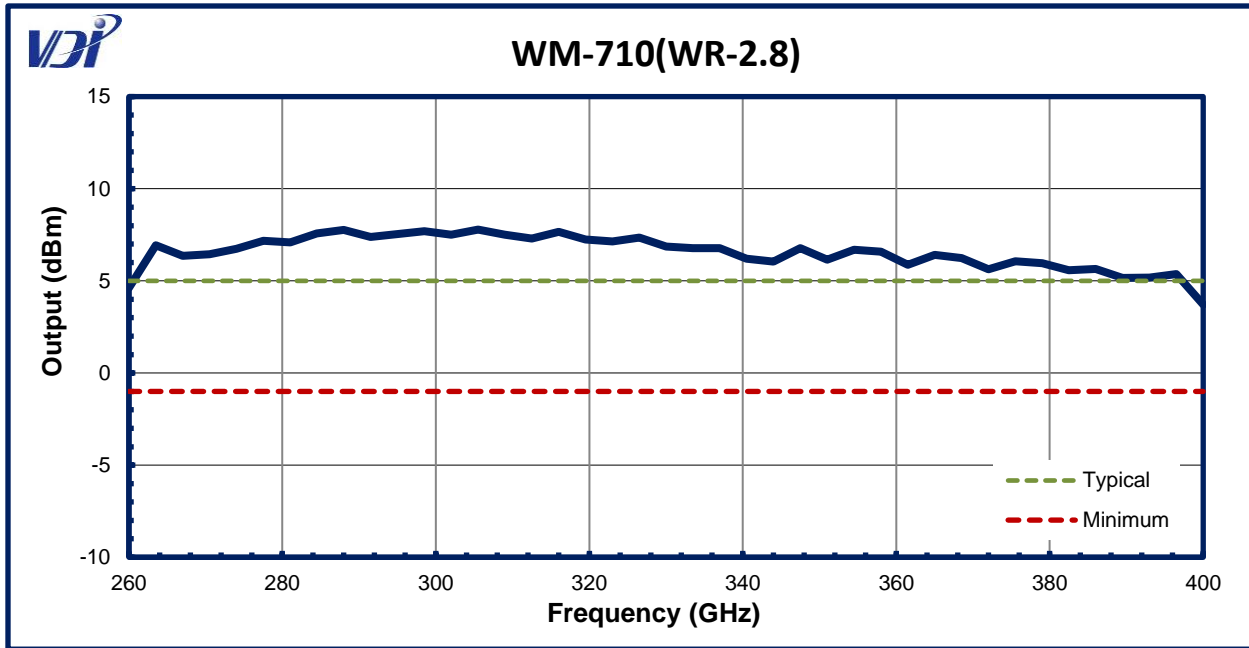
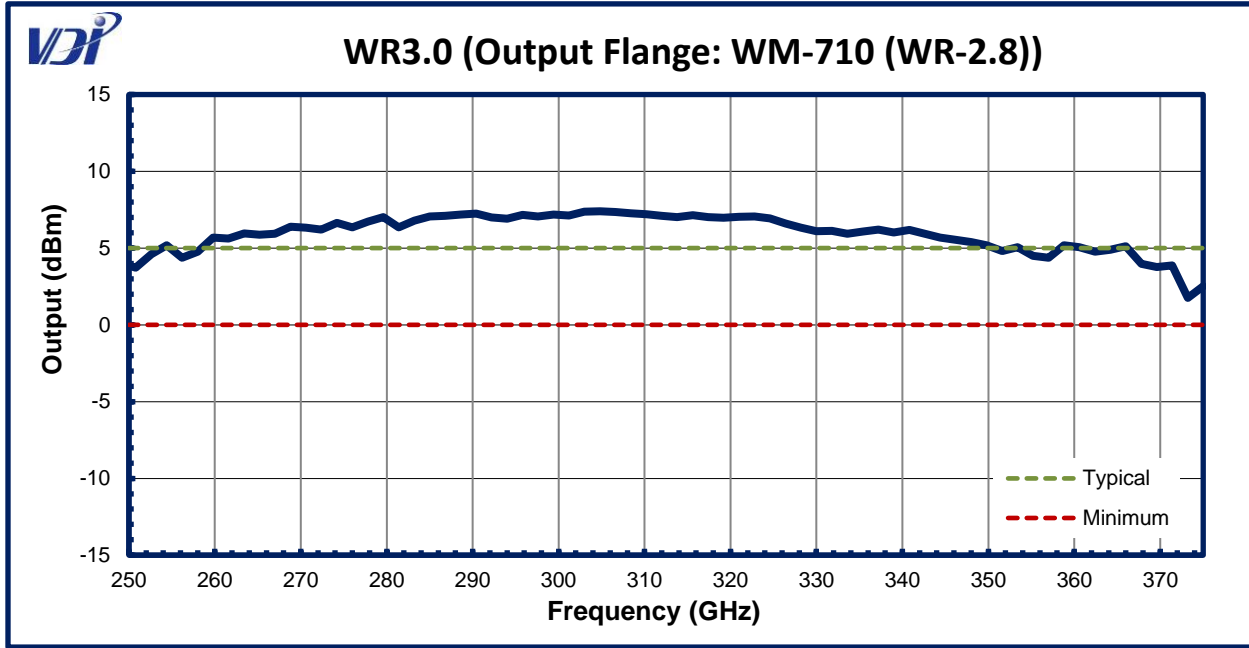

Test Port Power - continued

AMC-I Performance — Continued

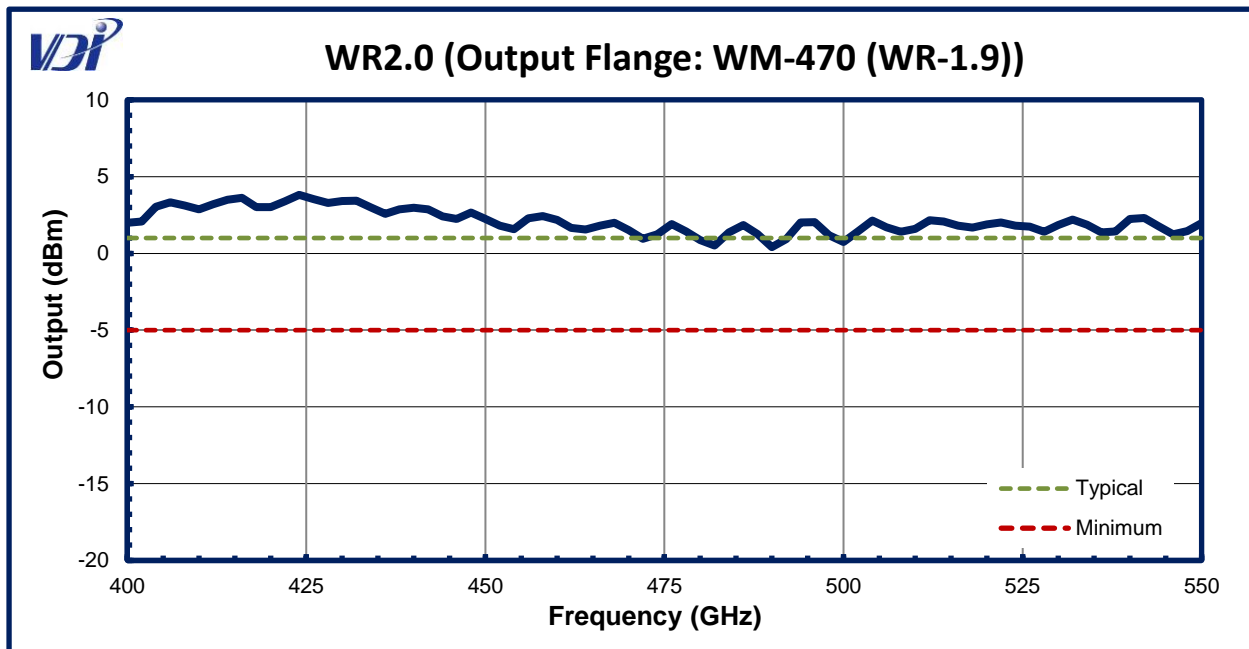
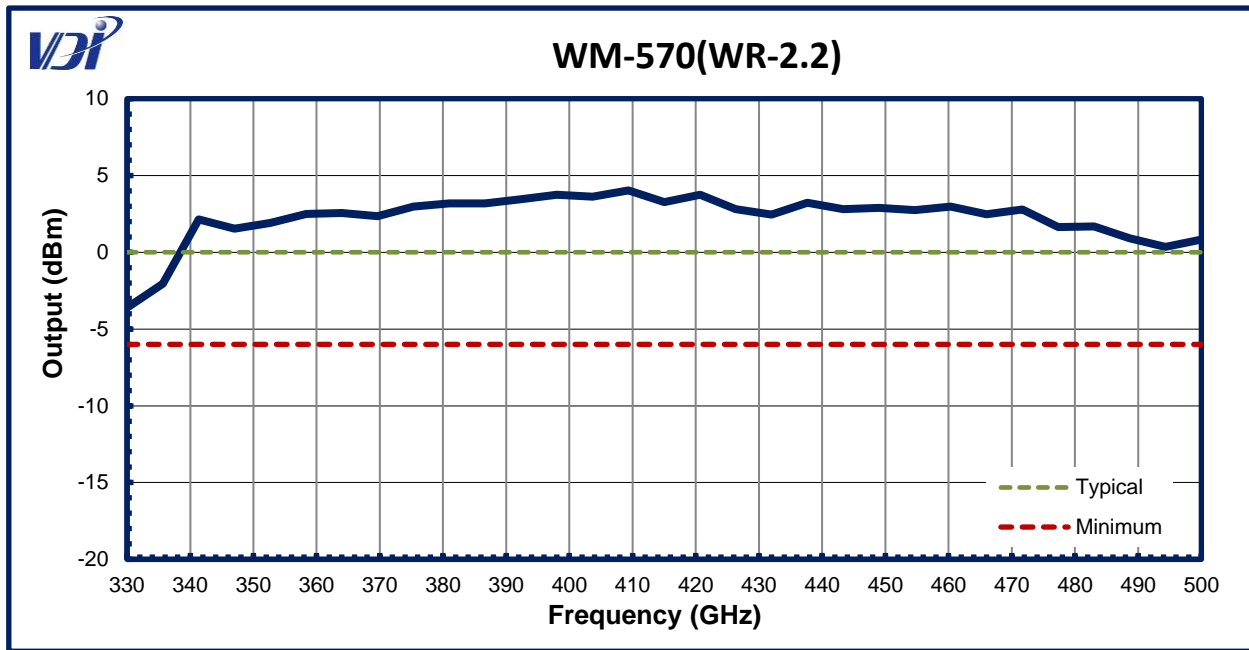

Test Port Power - continued

AMC-I Performance — Continued

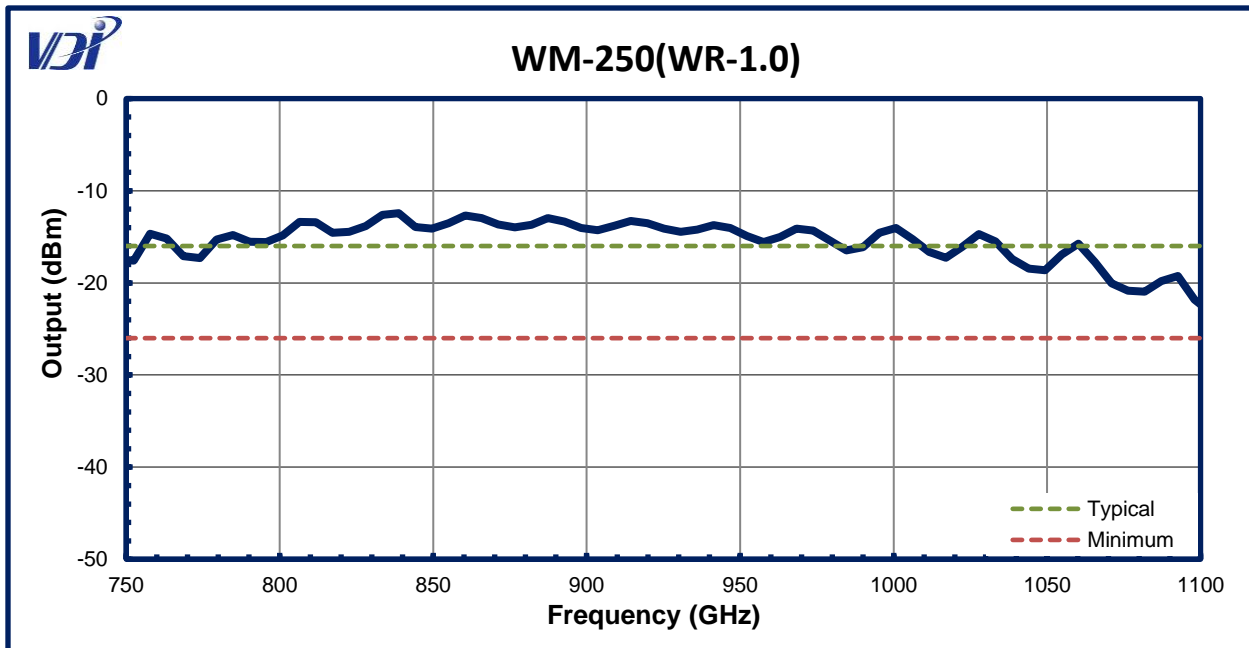
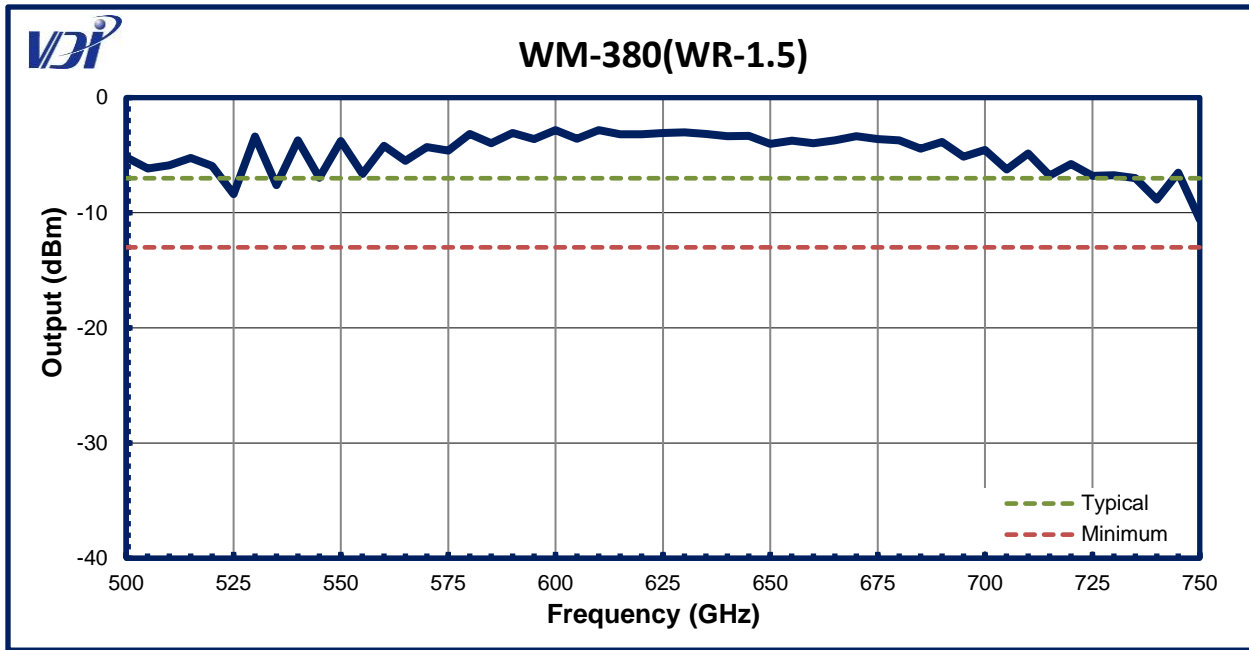

User Controlled Attenuation (UCA) Performance

Note: The UCA voltage reduces the module's output power. The UCA is only recommended by about 10dB and for higher values an external waveguide attenuator is recommended (see the Options List). The data presented in these graphs was measured by VDI under specific test conditions. These graphs are intended to be used as examples to show a module's nonlinearity and frequency dependence. The exact shape of the curves will vary significantly depending on the measurement conditions, including operating temperature, modulation rate, duty cycle, and load impedance.

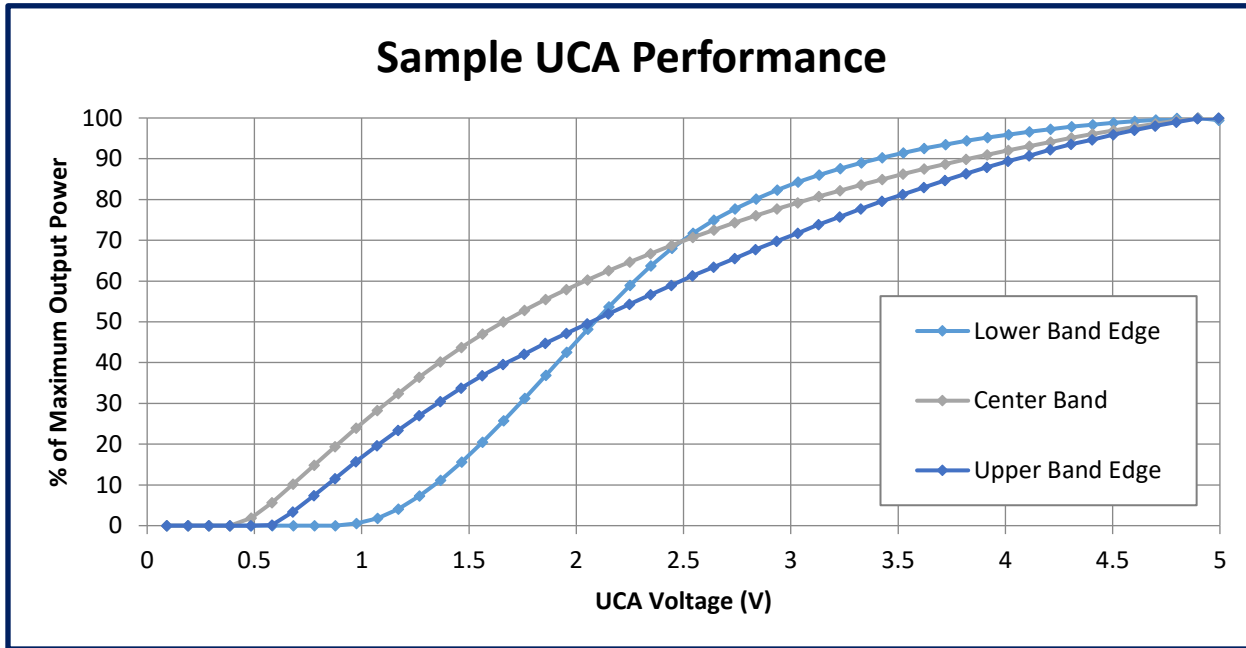

Addendum — Product Updates and Company Contacts

The Virginia Diodes staff of engineering and physical science professionals works to continually improve our products. We also depend upon feedback from colleagues and customers. Ideas to simplify operations, improve performance or add capabilities are always welcome.

Contact VDI:

Virginia Diodes, Inc.

Web: <http://www.vadiodes.com>

Email: Technical@vadiodes.com

Telephone: 434.297.3257