

# Subharmonic Mixer (SHM) Operational Manual



---

979 Second Street SE, Suite 309  
Charlottesville, VA 22902-6172 (USA)  
Tel: 434.297.3257; Fax: 434.297.3258  
[www.vadiodes.com](http://www.vadiodes.com)

---

**Section 1 – SHM General Overview, Safety and Operational Guidelines ..... Pages 2-3**  
 Contents ..... Page 2  
 SHM General Overview, Safety and Operational Guidelines ..... Page 3

**Section 2 – Product Overview and Technical Specifications ..... Pages 4-6**  
 Product Overview ..... Page 4  
 Double-Sideband Up-Conversion and Down-Conversion..... Page 5  
 Product Specifications..... Page 6

**Appendix 1 – SHM Performance..... Pages 7-8**  
 SHM Performance – WR15 and WR10 ..... Page 7  
 SHM Performance – WR6.5 and WR2.2..... Page 8

**Appendix 2 – Compression vs. RF Input Power ..... Pages 9**  
 Compression vs. RF Input Power ..... Page 9

**Appendix 3 – IF Amplifier Pre-testing before use with VDI Mixer .....Pages 10**  
 IF Amplifier Pre-testing before use with VDI Mixer ..... Page 10

**Addendum – Product Updates and Company Contacts ..... Page 11**

# SHM General Overview, Safety and Operational Guidelines

## Subharmonic Mixers (SHM)

Virginia Diodes offers subharmonically pumped mixers (SHMs) for frequency up and down-conversion. These mixers are easy to use and well suited for millimeter-wave and terahertz applications. They also offer excellent conversion loss and noise temperature performance compared to other room temperature SHMs. VDI SHMs offer full waveguide band coverage and are available from WR15 (50-75 GHz) to WR0.8 (900-1400 GHz). Higher frequency custom mixers are available upon request.

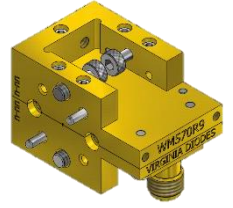

## Safety and Operational Guidelines



Read all instructions and information in this product manual before connecting the product to external equipment. Operational procedures must be followed for proper function. If you have questions, contact VDI before operating the product.



The internal components of every mixer can be damaged by Electro Static Discharge (ESD). Any operator using or handling the device should wear a grounded wrist strap specifically designed to guard against ESD. The work environment including test benches should also be properly grounded.



VDI assumes the customer is familiar with microwave, millimeter wave and VDI products in general. The user and customer are expected to understand all safety guidelines, health hazards and general advisories that may exist and are associated with the use of this device. VDI is not responsible for any human hazards that may exist or may occur while using this device.

## Virginia Diodes, Inc. (VDI) accepts no liability for damage or injury resulting from or caused by:

- Improper use, disassembly or use for purposes other than those for which the product was designed;
- Use outside common safety, health or general advisories pertaining to microwave, millimeter wave and VDI products;
- Repairs carried out by persons other than VDI or its assigned agents.

## Waveguide Inspection / Test Port Care

- Inspect waveguide flanges for debris prior to making connections.
- Making a connection with debris between the waveguide flanges can damage the waveguide interface and prevent repeatable connections.
- If debris is present, clean the flange with pre-dampened lint free wipes or swabs (e.g. TexWipe TX1065). If these are not available, lint free cloths lightly dampened with ethanol may be used (e.g. TexWipe TX604).
- When device is not in use, cover appropriate waveguide flanges with provided dust cap or protective waveguide tape.
- Waveguide screws should be torqued between 20-50 cNm, greater values can damage the interface.
- Use a torque of 90 cNm when making coaxial connections. Avoid sharp bends in cables.

## General Operating Practices and Recommendations

- This manual applies to products shipping after April 13, 2017.
- Check with VDI before any use is attempted beyond those described in this manual, including uses that may exceed limitations stated here or commonly accepted standards of practice.

### Low Frequency Subharmonic Mixers (WR-15 to WR-10) – Coaxial LO Input Port

These mixers have a coaxial LO input port and a rectangular waveguide RF port. The drawing and corresponding dimensions are for a typical WR-15 subharmonic mixer. WR12SHMs and WR10SHMs have similar configuration and dimensions.

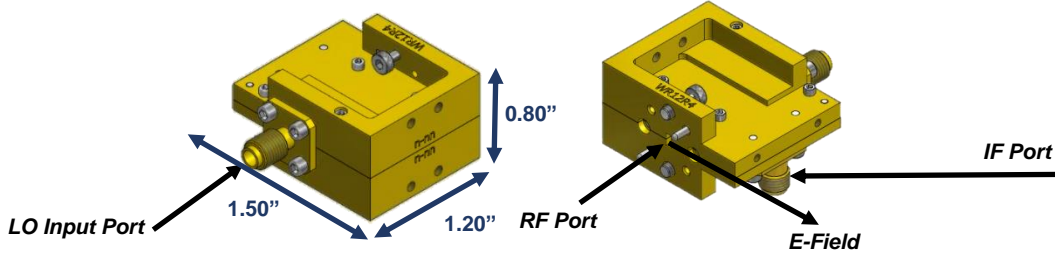

### Middle Frequency Subharmonic Mixers (WR-8.0 to WR-1.0) – Waveguide LO Input Port

These mixers have rectangular waveguide LO and RF ports. The drawing and corresponding dimensions are for a typical WR-2.2 subharmonic mixer. Other SHMs (WR-8.0 to WR-1.0) have similar configuration and dimensions.

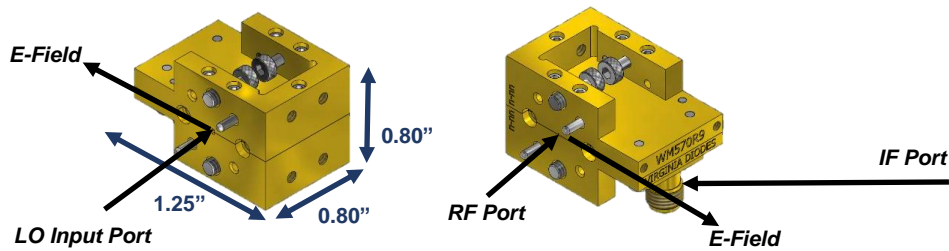

### High Frequency Subharmonic Mixers (WR-0.8) – Integrated Horn RF Input Port

These mixers have a rectangular waveguide LO input port; the RF port is an integrated horn antenna (~25dBi). The drawing and corresponding dimensions are for a typical WR0.8 subharmonic mixer.

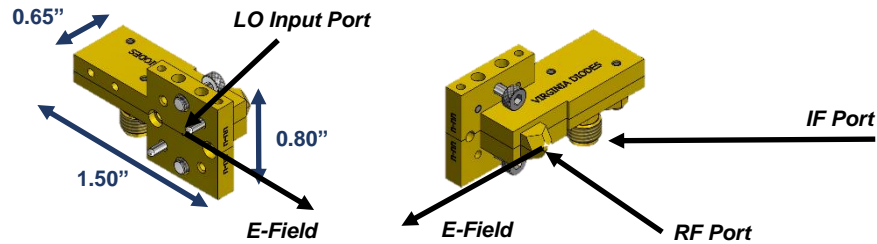

## General Operating Procedure

**Turn On:** Apply appropriate LO power to the device then apply small signal input power.

**Turn Off:** Turn off small signal input power then turn off LO input power.

**LO Input:** The SHM is a 2<sup>nd</sup> harmonic mixer, therefore the LO input frequency is ~½ of the RF frequency. The user must adjust LO power at each frequency for optimal performance. DO NOT exceed damage limits listed on Page 6.

**IF Port (Extremely ESD Sensitive):** The IF port can be used as an input or an output depending on the configuration (see Page 5). The IF port is extremely ESD sensitive. DO NOT apply any DC biases or surges when connecting / disconnecting from IF port. Discharge static from cables before connecting to the device. DO NOT exceed damage limits listed on Page 6. Replace IF port with provided 50Ω termination when IF port is not in use.

**RF Port:** The RF port can be used as an input or an output depending on the configuration (see Page 5). DO NOT exceed damage limits listed on Page 6.

Failure to follow these procedures may damage or destroy the device. The user is liable for repair costs of detectors damaged by ESD, and the use of stringent ESD precautions is recommended when making connections to VDI mixers.

# Double Side-Band Up-Conversion and Down-Conversion

VDI SHMs can be used to down-convert a block of millimeter-wave / THz signals to the IF band, where it can then be coupled into the RF port of an analyzer or processed by other means. The SHMs can also be used to up-convert a block of IF signals to generate a block of millimeter-wave / THz signals for transmission from the RF port.

## Block Down-Conversion

Figure 1 shows how a VDI SHM down-converts a block of millimeter-wave signals. It is important to note that due to the double sideband nature of the SHMs, the mixer will process both sidebands. The upper and lower sidebands will be down-converted to the same range IF output frequencies.

The IF Output frequency can be calculated by:  $f_{IF} = |f_{RF} - 2 \cdot f_{LO}|$

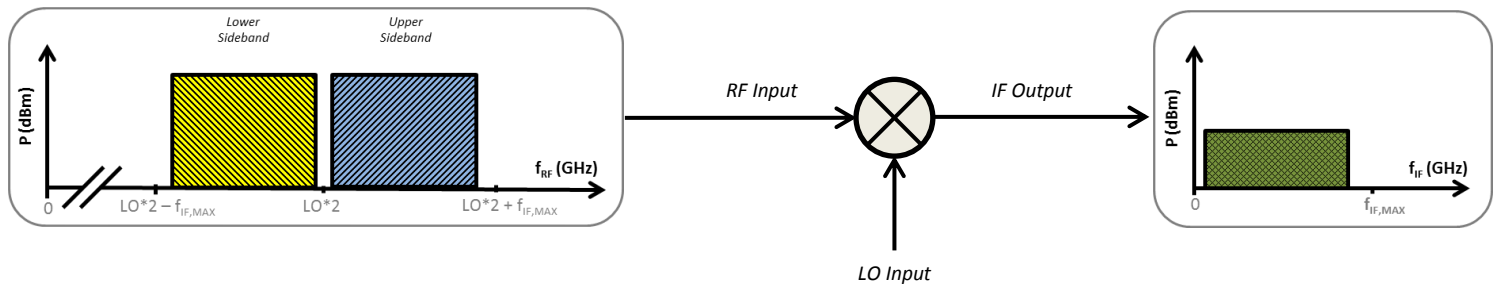

Figure 1: Diagram of block down-conversion is shown.

## Block Up-Conversion

Figure 2 shows how a VDI SHM up-converts a block of IF input signals. Due to the double sideband nature of the SHMs, two sidebands (upper and lower sidebands) are generated during the up-conversion process. A filter may be preferred for certain applications to eliminate one sideband.

The lower sideband RF Output frequency can be calculated by:  $f_{RF-lower} = 2 \cdot f_{LO} - f_{IF}$

The upper sideband RF Output frequency can be calculated by:  $f_{RF-upper} = 2 \cdot f_{LO} + f_{IF}$

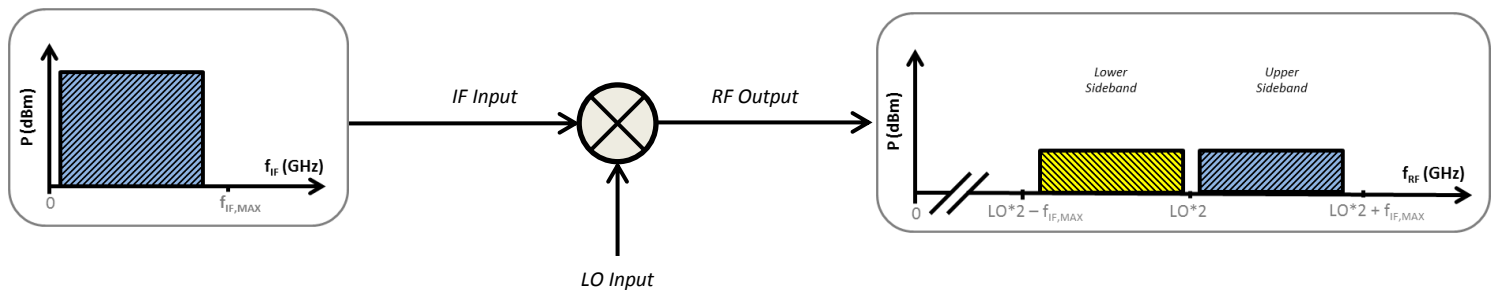
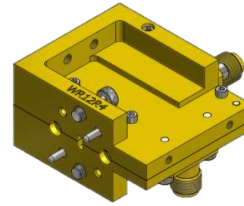

Figure 2: Diagram of block up-conversion is shown.

# Product Specifications

General Specifications for Subharmonic Mixers		
Description		Specification
RF Input Power†	Linear Region	< -10 dBm
	Damage	0 dBm
LO Input Power	Recommended	3-6 dBm††
	Damage	9 dBm
IF Port	-	2.9mm(f)*
Maximum Weight	-	~0.1 lbs.
Operating Temperature	Typical / Recommended	25°C / 20-30°C



†For down-conversion. The IF input for up-conversion applications will have the same input power requirements.

††For WR15 to WR2.8 models only. For higher frequency SHMs, 4-8 dBm LO input power is required for optimal performance.

\*Standard configuration for SHMs includes a 2.9mm(f) IF connector. In frequency bands WR2.8 and higher, a 2.4mm(f) IF connector can yield slightly higher available IF. Contact VDI for more information.

Product Specifications for Subharmonic Mixers							
VDI Part Number	RF Frequency (GHz)	LO Frequency (GHz)	Maximum IF Frequency (GHz)**	RF Flange†	LO Flange†	DSB Performance	
						Conversion Loss (dB, typ.)††	Noise Temperature (K, typ.)††
WR15SHM	50-75	25-37.5	10	WR-15	2.9mm(f)	7	400-800
WR12SHM	60-90	30-45	12	WR-12	2.4mm(f)	7	400-800
WR10SHM	75-110	37.5-55	15	WR-10.0	1.85mm(f)‡	7	400-800
WR10SHM-W	75-110	37.5-55	15	WR-10.0	WR-20‡	7	400-800
WR8.0SHM	90-140	45-70	19	WR-8.0	WR-16.0	7	400-800
WR6.5SHM	110-170	55-85	24	WR-6.5	WR-13.0	7	400-800
WR5.1SHM	140-220	70-110	31	WR-5.1	WR-10.2	7.5	500-1000
WR4.3SHM	170-260	85-130	36	WR-4.3	WR-8.6	8	600-1200
WR3.4SHM	220-330	110-165	40	WR-3.4	WR-6.8	8.5	700-1400
WR2.8SHM	260-400	130-200	40	WR-2.8	WR-5.6	9	800-1500
WR2.2SHM	325-500	162.5-250	40	WR-2.2	WR-4.4	9.5	1000-2000
WR1.9SHM	400-600	200-300	40	WR-1.9	WR-3.8	10	1200-2500
WR1.5SHM	500-750	250-375	40	WR-1.5	WR-3.0	11	2000-5000
WR1.2SHM	600-900	300-450	40	WR-1.2	WR-2.4	15	7500-15000
WR1.0SHM	750-1100	375-550	40	WR-1.0	WR-2.0	20	7500-15000
WR0.8SHM	900-1400	450-700	40	Diagonal Horn*	WR-1.6	20	10000-20000

†RF and LO †RF and LO Flanges with 'WR' designation have UG-387/U-M flanges, with the exception of the WR-20 and WR-15 which have a UG-383/U and UG-385/U flange.

††Conversion Loss and Noise Temperature performance are specified at ~1 GHz IF. Conversion loss increases as a function of IF, at a rate of ~1dB/10GHz, up to the specified Maximum IF Frequency. Performance is typical with reduced performance at band edges.

‡WR10SHMs can be configured with a WR-20 UG-383/U waveguide or 1.85mm(f) coaxial flange.

\*Diagonal Horn antenna has a gain of ~25dBi, specified at the middle of the waveguide band. The gain changes as a function of frequency. See VDI Application Note: VDI Waveguide Feedhorn Specification (VDI-1001) for more information.

\*\*Higher IF bandwidths may be available upon request. Contact VDI for more information.

## General Notes:

- VDI provides individualized DSB Conversion Loss and Noise Temperature at ~1 GHz IF for each component. Customized testing is available at additional cost. Contact VDI for more information.
- The required LO power for optimal performance varies across the frequency band. Performance specifications assume optimal RF and LO power coupled into the mixer; performance may be reduced near band edges.
- Where available, an input isolator will smooth the required LO input power vs. frequency.
- For WR1.5 and higher frequency SHMs, VDI will only test over ~25% of operational bandwidth. Please specify the desired frequency range. Additional testing can be purchased. Contact VDI for more information.

## SHM Double Side Band (DSB) Conversion Loss and Noise Temperature Performance

Typical DSB conversion loss and noise temperature data is provided below. The LO input power was optimized across the frequency band. The DSB conversion loss and noise temperature data was collected using the Y-factor method. Additional data can be found on the [VDI website](http://www.vadiodes.com) or may be available upon request (technical@vadiodes.com). Measured conversion loss and noise temperature data will be shipped with each VDI SHM.

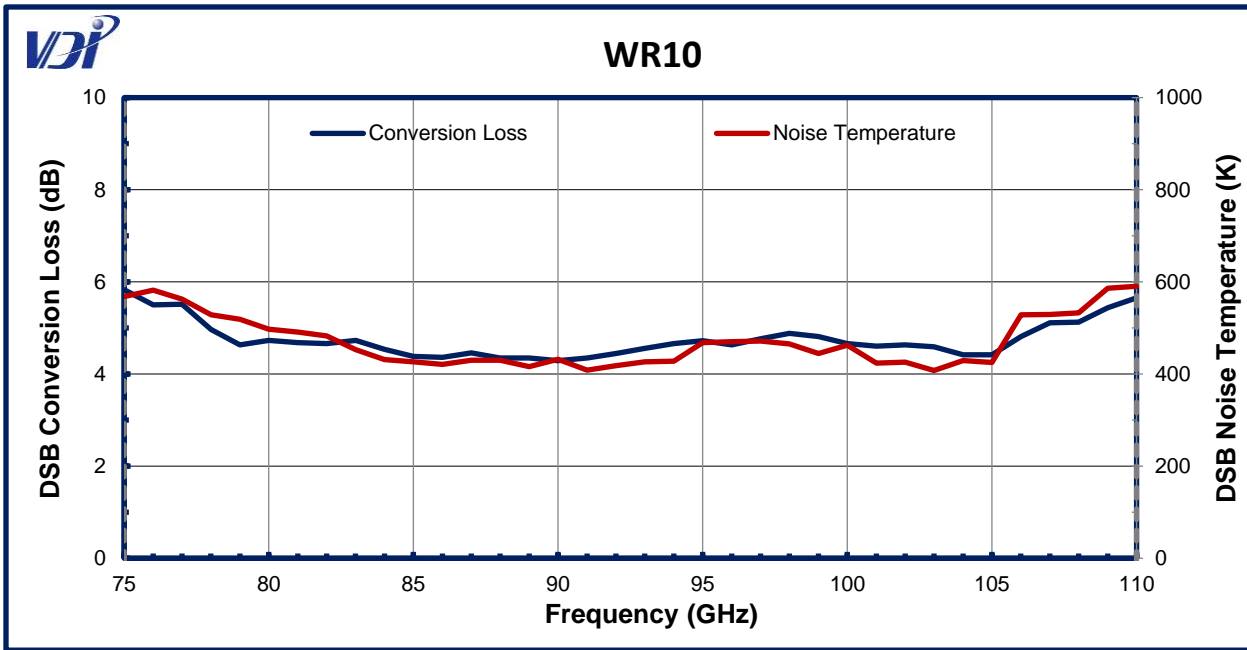
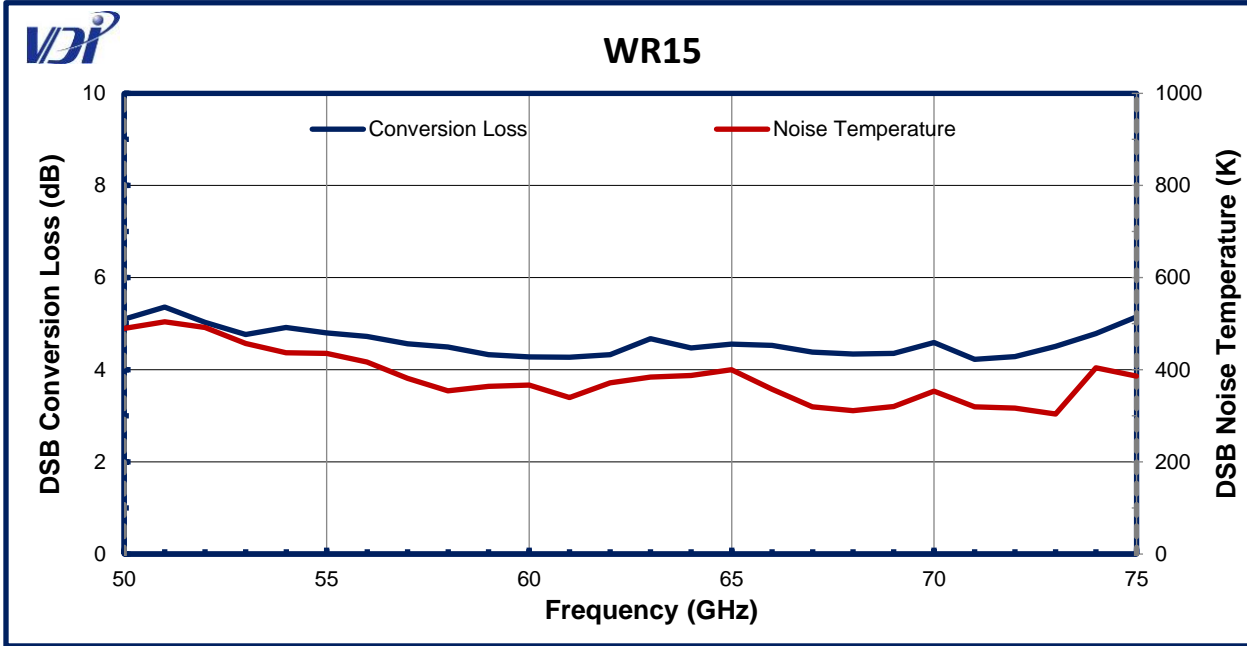

# SHM Performance – WR6.5 and WR2.2

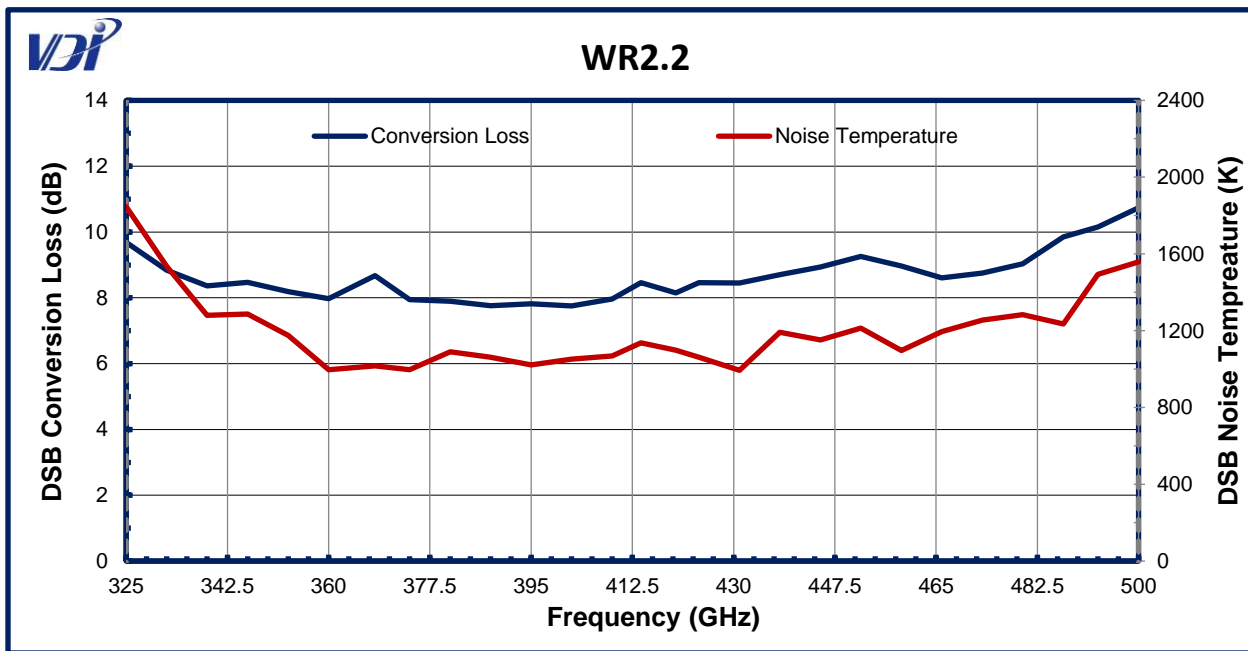
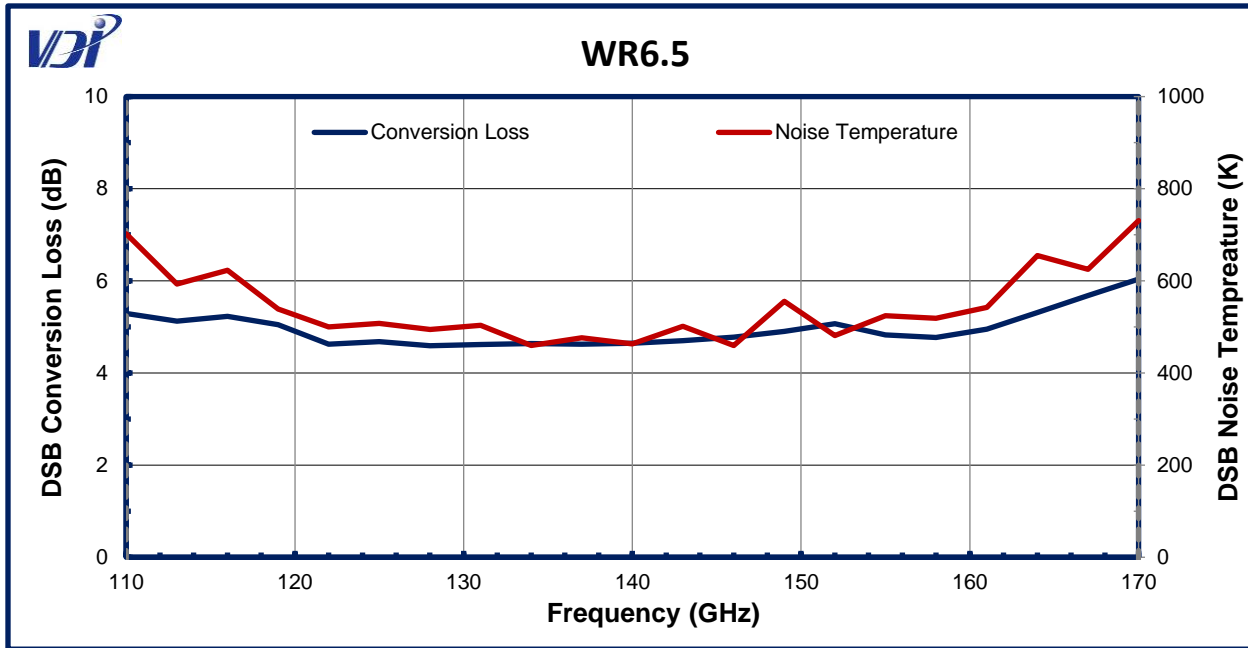



## Compression vs. RF Input Power

This graph shows measured mixer RF compression data for a specific WR-15 subharmonic mixer at ~60 GHz for various LO input powers. Mixer compression is defined as the increase in mixer conversion loss relative to the conversion loss of the mixer in the linear region.

The general shape of the curve is consistent with all VDI's subharmonic mixers. However, the scale depends on the specific SHM design, the operating frequency and other operating conditions, such as LO input power and temperature.

Compression versus power data can be supplied for all shipped SHMs at an additional cost.

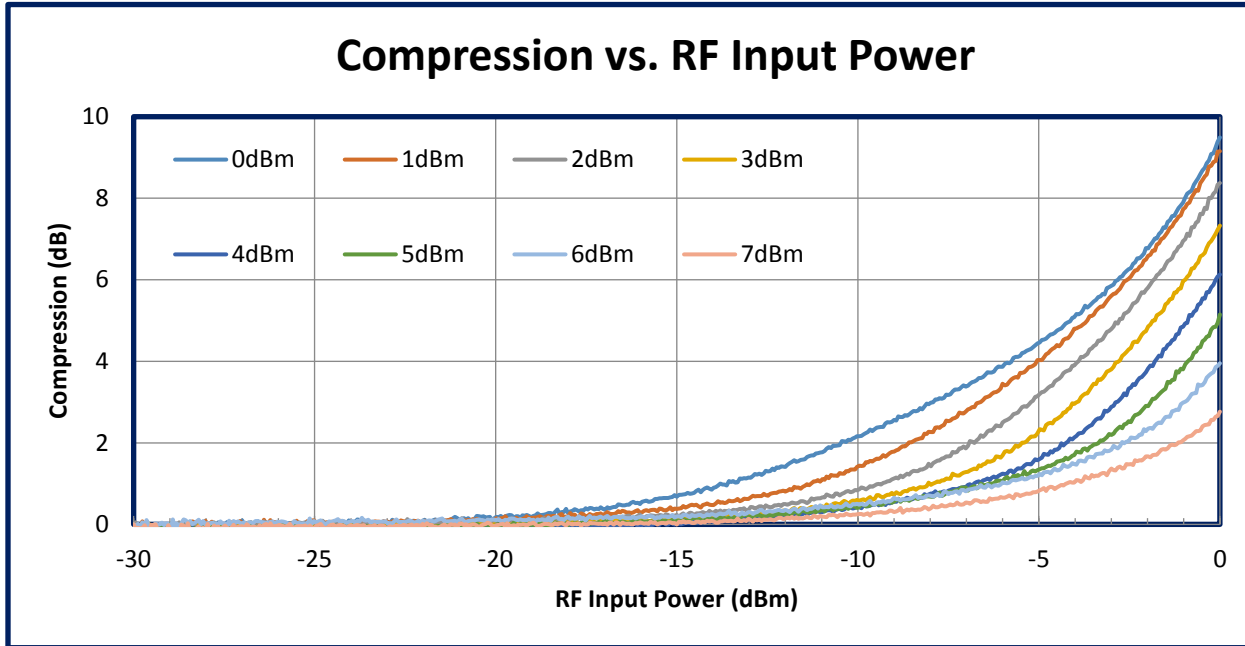
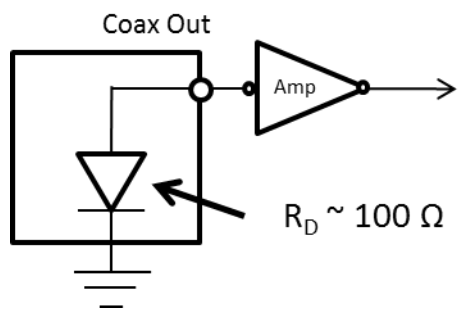

**Figure 3: Compression vs. RF Input Power**

The performance (compression vs. RF input power) is shown for a sample WR15SHM at ~60 GHz for various LO input powers.

Though VDI SHMs offer extremely wideband performance, they are extremely ESD sensitive at its coaxial (IF) port. To add ESD protection, an IF amplifier is recommended. However, some IF amplifiers can exhibit bias or turn-on transients at the amplifier input, which can damage the VDI SHM. Even with AC coupling at the amplifier input, transients can occur when the amplifier bias is applied rapidly.

Before using an amplifier with a VDI mixer, it is recommended that bias or turn-on transients at the amplifier input be tested. Attach a  $100\ \Omega$  resistor to the input of the amplifier. Monitor the resistor voltage on an oscilloscope as the amplifier bias is applied. The turn-on transient voltages across the resistor should be kept less than  $\sim 100\text{mV}$  for safe operation.



**VDI Mixer with External Amp**

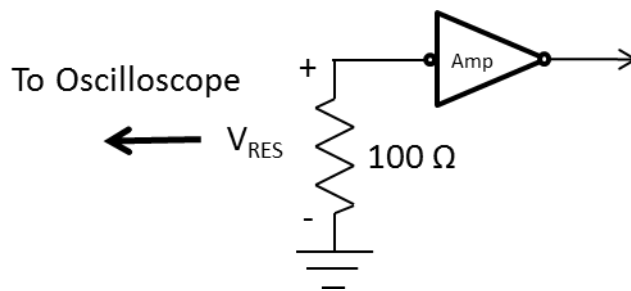

**Turn-on Transient Testing**

### Figure 4: Amplifier Pre-Testing

Block diagrams of amplifier pre-testing, prior to use with VDI mixer is shown.

# Addendum — Product Updates and Company Contacts

The Virginia Diodes staff of engineering and physical science professionals works to continually improve our products. We also depend upon feedback from colleagues and customers. Ideas to simplify component operations, improve performance or add capabilities are always welcome.

## Contact VDI:

### Virginia Diodes, Inc.

Web: <http://www.vadiodes.com>

Email: [Technical@vadiodes.com](mailto:Technical@vadiodes.com)

Telephone: 434.297.3257