

WR10 and WR9.0 Modular Mini SGX Addendum

Modular Mini SGX Overview

Virginia Diodes (VDI) offers external multipliers compatible with WR10 (75-110 GHz) and WR9.0 (82-125 GHz) Mini SGX Modules to extend the frequency coverage up to ~1 THz. Some external multipliers may require bias from the Voltage Bias Ports on the front panel of the Mini SGX. For information on how to operate the Mini SGX Modules please refer to VDI-730.2 (Mini SGX Product Manual). External multipliers compatible with other Mini SGX Modules may be available. Contact VDI for more information.



Block Diagrams

WR9.0 Modular Mini SGX Configuration

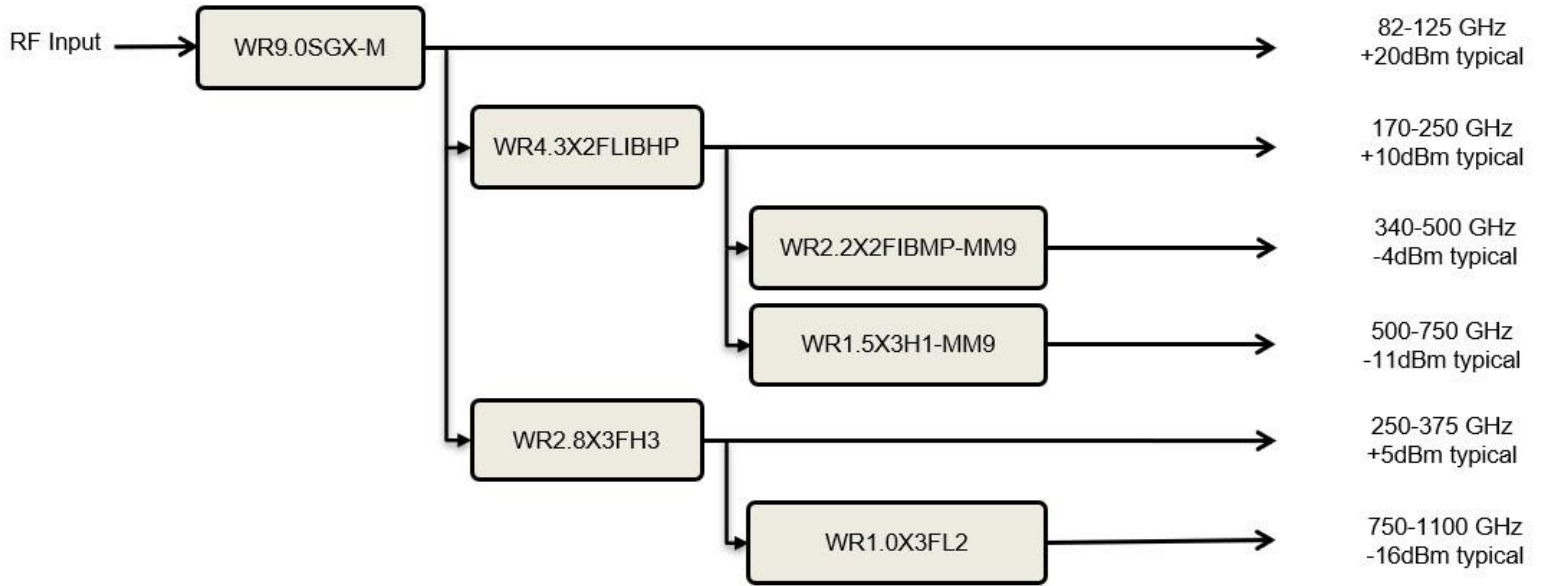

WR10 Modular Mini SGX Configuration

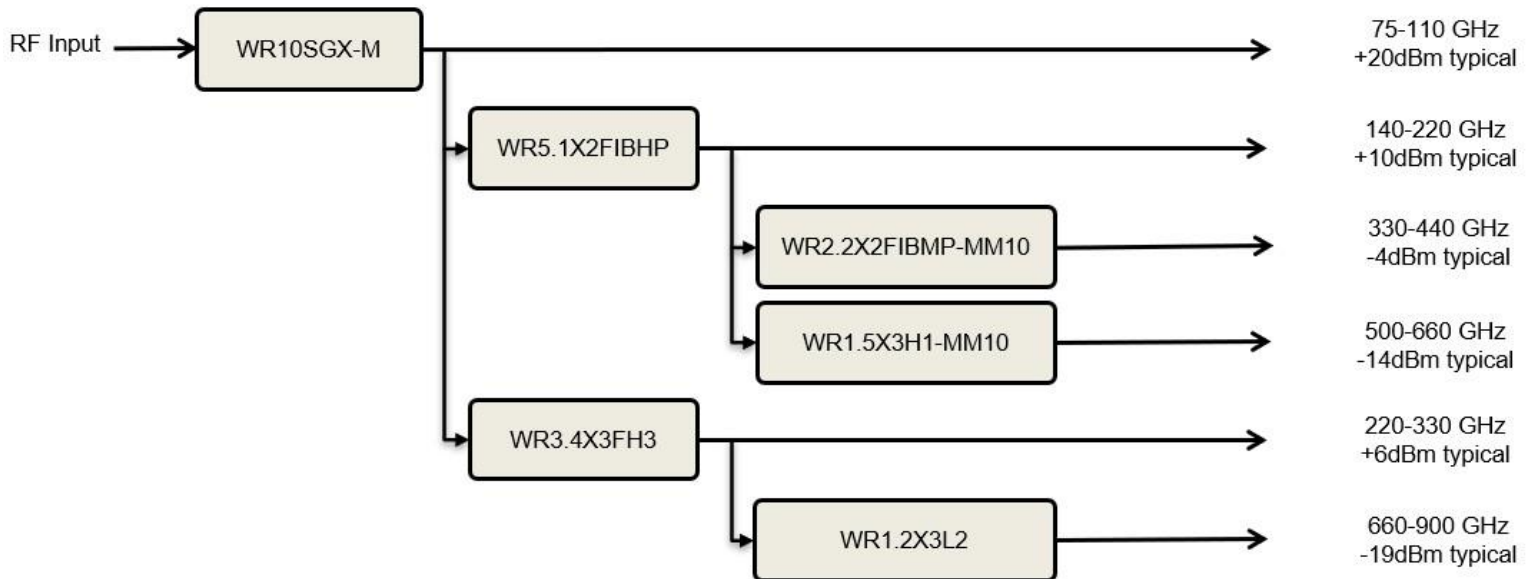

Configuration Photos

Photos below are a typical configuration. Exact formfactor of multipliers are subject to change.

WR9.0 Base Unit



WR10 Base Unit



Typical Performance

