



Product Overview – Mini Signal Generator Extension Module (SGX-M)



Virginia Diodes, Inc.

979 2nd St SE, Suite 309

Charlottesville, VA 22902-6172 (USA)

Tel: 434.297.3257

Fax: 434.297.3258

Contents

General Operating Practices and Recommendations	3
Mini Signal Generator Extension Modules	3
Safety and Operational Guidelines	4
RF Drive Limitations.....	4
Safety Guidelines	4
Waveguide Test Port Care	4
General Operating Practices and Recommendations	4
Product Views, Block Diagrams and Specifications	5
Major Components and Accessories	5
Module Details – Front and Rear Panel Connections.....	6
SGX-M Configurations	7
General Operating Procedures.....	9
SGX-M Test Port Power	10
Test Port Power for WR-28 and WR-19	10
Test Port Power for WR-15 and WR-15 (SE).....	11
Test Port Power for WR-12 and WR-12 (SE).....	12
Test Port Power for WR-10 and WR-9	13
Test Port Power for WR-8 and WR-6.5	14
Test Port Power for WR-5.1 and WR-4.3	15
Test Port Power for WR-3.4 and WM-710 (WR-2.8)	16
Test Port Power for WM-570 (WR-2.2) and WM-380 (WR-1.5).....	17
Test Port Power for WM-250 (WR-1.0)	18
SGX-M – User Controlled Attenuation (UCA) Performance	19
Cable Loss Characterization.....	20
Cable Loss Characterization Data	20
SGX-M Module Drawings	21
Mechanical Drawing – All SGX-M Modules	21
Addendum – Product Updates and Company Contacts	22



General Operating Practices and Recommendations

Mini Signal Generator Extension Modules

Virginia Diodes' Mini Signal Generator Extension (SGX-M) modules are used to extend the performance of microwave signal generators in the frequency range from 26.5 GHz through 1.1 THz, in frequency bands from WR-28 (26.5-40 GHz) to WM-250 (750-1100 GHz). These modules offer high test port power with full waveguide band coverage. Standard features include direct extension include TTL controlled ON/OFF modulation up to ~ kHz and voltage controlled RF attenuation. Additional options and accessories are available. Options include: RF cables, external micrometer driven variable RF output attenuators, test port extensions, and horn antennas for free-space coupling.



Note: Signal Generator Extension Modules DO NOT preserve amplitude, phase and frequency modulations (e.g. QPSK, 16QAM, 256QAM, etc). Signal Generator Extension Modules are intended to be used in CW mode or OOK modulation (ON/OFF).



FIGURE 1 - FRONT AND REAR VIEWS OF SGX-M EXTENSION MODULES



Safety and Operational Guidelines

 Read all instructions and information in this product manual before connecting a module to its power supply or a signal generator. Operational procedures must be followed for proper function. If you have questions, contact VDI before supplying power to or otherwise operating any VDI module.

 VDI assumes the customer is familiar with microwave, millimeter wave and VDI products in general. The user and customer are expected to understand all safety guidelines, health hazards and general advisories that may exist and are associated with the use of this device. VDI is not responsible for any human hazards that may exist or may occur while using this device.

RF Drive Limitations

 Recommended RF input power specifications are noted on the label on the top of every VDI module. See examples on Page 8; these values provide optimal performance. Irreversible damage can result if input power exceeds stated damage threshold.

Safety Guidelines

- VDI accepts no liability for damage or injury resulting from or caused by:
 - Improper use, disassembly or use for other purposes than for which the product was designed.
 - Use outside common safety, health or general advisories pertaining to microwave, millimeter-wave and VDI products.
 - Repairs carried out by persons other than VDI or its assigned agents.
 - Tampering with or altering power cords or other cabling.

Waveguide Test Port Care

- Inspect waveguide flanges for damage or debris prior to making connections.
- Torque waveguide screws in the range of 20-50cNm when making waveguide flange connections. Greater torque can damage the interface.
- Making a connection with metal debris between the waveguide flanges can damage the waveguide interface and prevent repeatable connections.
- If debris is present, clean the flange with pre-dampened TexWipe wipes or swabs (e.g. Part Number TX1065).
- If these are not available, TexWipe cloths lightly dampened with ethanol may be used (e.g. Part Number TX604).
- Cover test ports with dust caps when the system is idle.

General Operating Practices and Recommendations

- VDI SGX-M Modules are intended to be used in typical laboratory conditions.
- Use of any attachments and accessories not authorized by VDI or that do not meet VDI's specifications may void a module's limited warranty and could pose a hazard to the operator, or cause lasting damage to the device.
- DC bias cables provided by VDI must be used. Alternative and replacement cables cannot be used unless the DC cables are adequately rated, properly grounded and authorized for use by VDI.
- Each VDI module is intended for use only with its AC/DC converter as supplied by VDI. Use of other power supplies or converters could damage the device or injure the operator.
- Disassembling a module can cause lasting damage to components and pose a hazard to the operator.
- Applying liquids (other than the TexWipe wipes / cloths used for cleaning) can cause lasting damage to the module.
- Check with VDI before any measurement connection is attempted beyond those described in this manual or if it may exceed commonly accepted standards of practice.



Product Views, Block Diagrams and Specifications

Major Components and Accessories

VDI Mini Signal Generator Extension (SGX-M) Modules and typical accessories are shown. The exact equipment delivered and especially the input limits (see labels) may vary. Contact VDI with RF input limit or general operational questions before powering-up any module.

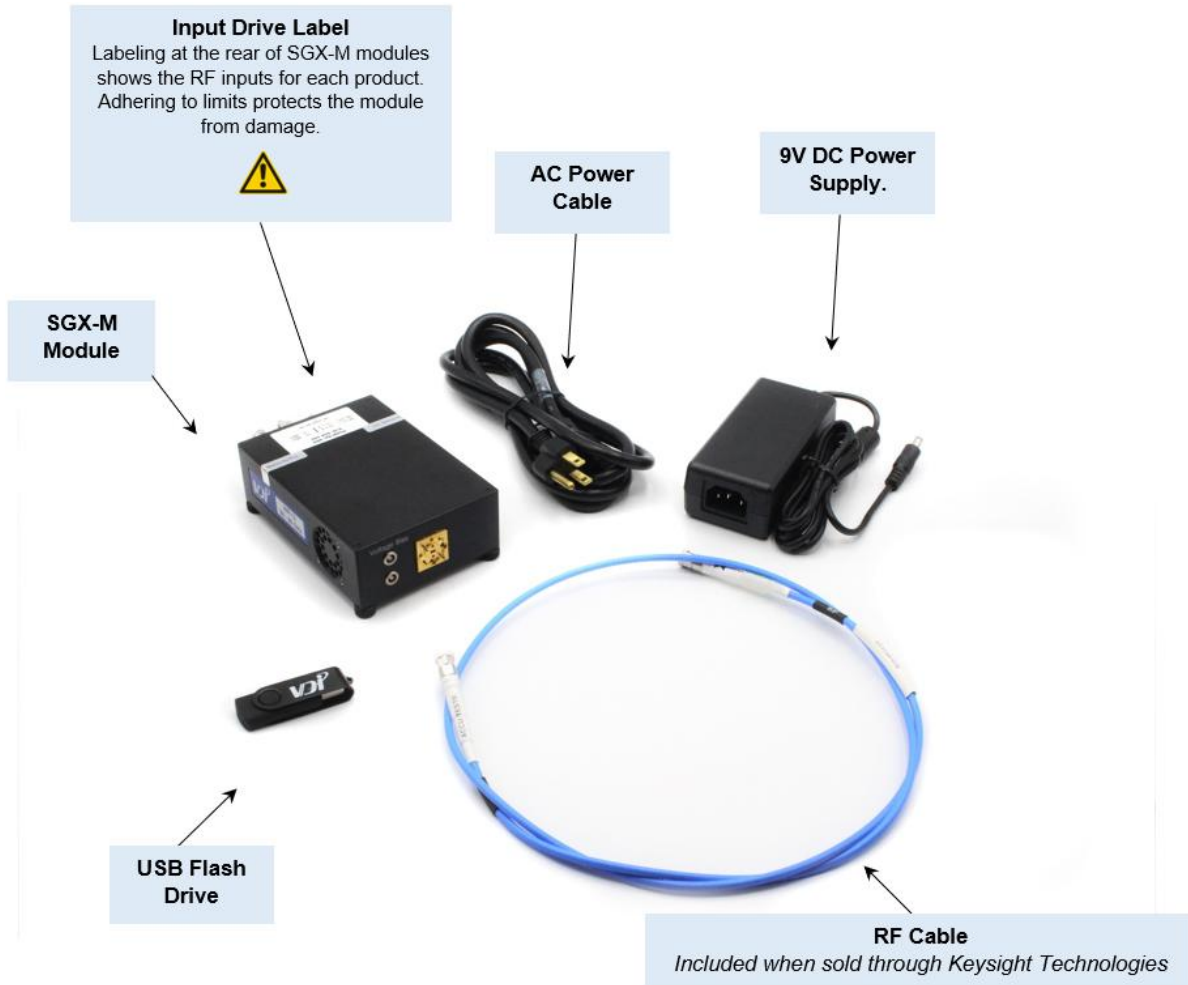

FIGURE 2 - MAJOR COMPONENTS AND ACCESSORIES



Module Details – Front and Rear Panel Connections

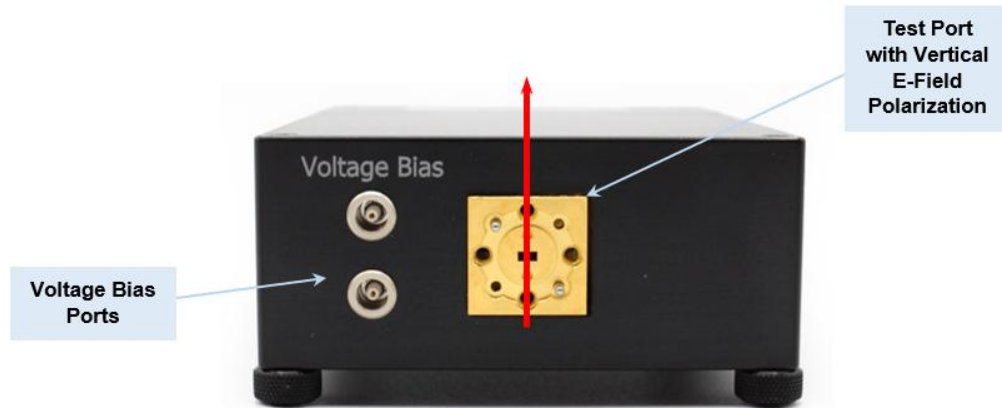

FIGURE 3 - SGX-M FRONT PANEL

**Voltage Bias Ports (+9V) are for use with external VDI components*

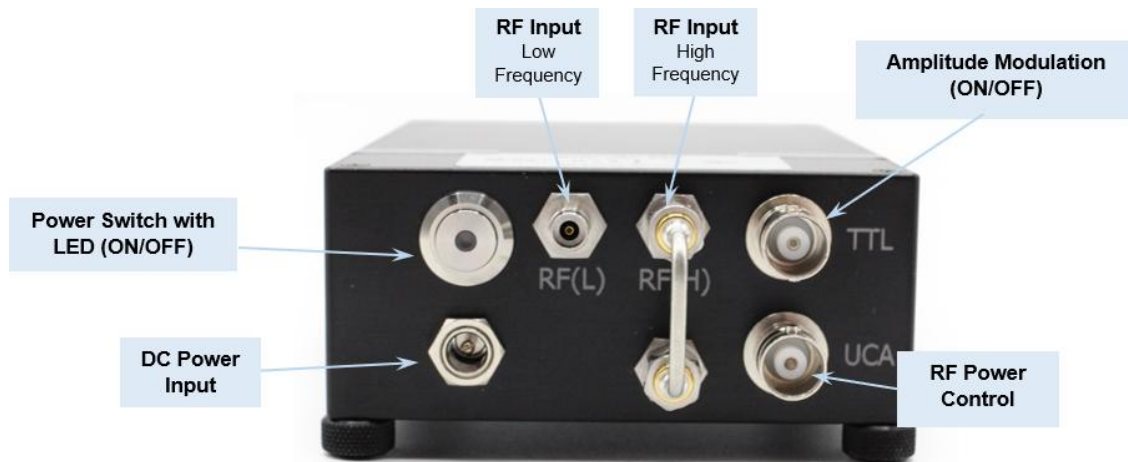

FIGURE 4 - SGX-M REAR PANEL



SGX-M Configurations

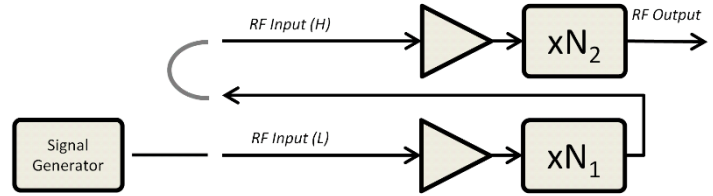

FIGURE 5 - LOW FREQUENCY OPERATION

Proper configuration details for Low Frequency operation are shown. A coaxial jumper connection must be used for Low Frequency operation. N_1N_2 is the multiplication factor this configuration.

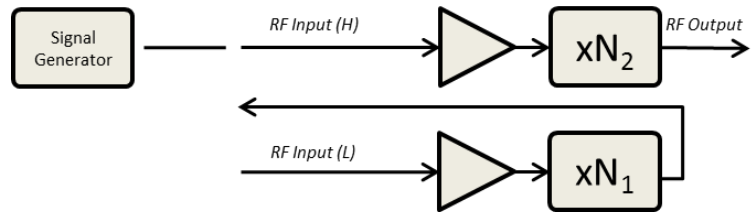
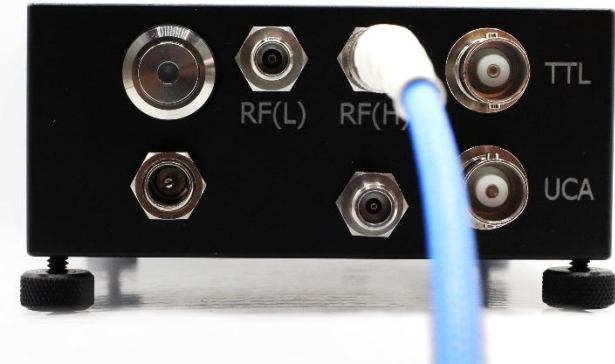

FIGURE 6 - HIGH FREQUENCY OPERATION

Proper configuration details for High Frequency operation are shown. Coaxial jumper must be removed for High Frequency operation. N_2 is the multiplication factor for this configuration.



General Specifications Signal Generator Extension Modules			
Description		Specification	Connector
RF Input	Low Freq. (Typical / Damage)	10 dBm ± 3dB / 16 dBm	2.92mm (f)
	High Freq. (Typical / Damage)	0 dBm ± 3dB / 6 dBm	2.4mm (f)
RF Output	VDI Standard Flange	Contact VDI for Details	UG-387/UM
AC Inputs	Single-Volt Power Supply (+9V/4A)	100-240VAC, 3.5A, 50-60Hz	U.S. or E.U.
Amplitude Modulation	TTL / AM Input (ON / OFF)	0 - 5 V, up to ~kHz, <1mA	BNC (f)
RF Power Control	User Controlled Attenuation (UCA) See Page 18	0V-off, 5V-full power	BNC (f).
Voltage Bias Port	For Use with External Components	+9V	LEMO 00
Operating Temperature	Typical / Recommended	25°C / 20-30°C	--
Maximum Weight	--	2.0 Lbs. (0.91 Kg.)	--
Dimensions	Typical (Length x Width x Height)	5.00" x 3.50 x 1.50"	--

Model No: SGX	
S/N: SGX 445	
RF (L) :	N = 6 10 dBm
RF (H) :	N = 3 0 dBm
DC Input: 9V---4A	

RF Drive Labels
Follow the RF input listed on extension module labels to avoid damage. Values shown here are only examples.



Summary of Performance Specifications for Mini Signal Generator Extension Modules									
Waveguide Band (GHz)	WR-28	WR-19	WR-15	WR-15 (SE)	WR-12	WR-12 (SE)	WR-10	WR-9.0	WR-8.0
Frequency Band (GHz)	26.5-40	40-60	50-75	50-75	60-90	60-90	75-110	82-125	90-140
Output Power (dBm, typ. / min.)	20 / 17	19 / 16	20 / 17	18 / 15	20 / 17	18 / 15	20 / 17	20 / 17	19 / 13
Mult. Factors (Low / High Freq)	4 / 2	4 / 2	6 / 3	6 / 3	6 / 3	6 / 3	6 / 3	9 / 3	12 / 6
Waveguide Band (GHz)	WR-6.5	WR-5.1	WR-4.3	WR-3.4	WM-710 (WR-2.8)	WM-570 (WR-2.2)	WM-380 (WR-1.5)	WM-250 (WR-1.0)	
Frequency Band (GHz)	110-170	140-220	170-260	220-330	260-400	330-500	500-750	750-1100	
Output Power (dBm, typ. / min.)	18 / 15	10 / 6	8 / 3	6 / 3	5 / -1	0 / -6	-7 / -13	-16 / -26	
Mult. Factors (Low / High Freq)	12 / 6	12 / 6	18 / 6	18 / 9	27 / 9	36 / 18	54 / 18	81 / 27	

Options List:

- External Micrometer Driven Attenuator (~0-30 dB)
- Horn Antenna
- Waveguide Test Port Extensions (1" and 2" available)
- Increased Amplitude / TTL Modulation Rate (-PIN Option) – Not available for all frequency bands. Contact VDI for more information.

General Notes:

- VDI SGX-M modules include a single-volt DC Power Supply.
- Turn-key, sweepable system, includes TTL modulation (ON/OFF up to ~kHz) and User Controlled Attenuation (UCA), 0-5V, both BNC.
- For increased Amplitude Modulation (ON/OFF) rates, VDI recommends using an external PIN switch.
- Unwanted harmonic content is better than -20dBc typical.
- SGX-M modules are configured to allow input signals in two bands. Low Frequency Operation: <20 GHz, ~10 dBm, 2.92mm(f). High Frequency Operation: removal of jumper allows higher frequency input, ~0 dBm, 2.4mm(f).
- Higher frequency input reduces unwanted harmonic signals within the band, and is preferred.
- SGX-M modules can be driven by any signal generator that supplies the required frequency band and power.
- Stability of the input is degraded by the harmonic factor N and phase noise by 20log(N).



General Operating Procedures

The safety and operational guidelines are listed on page 4. VDI recommends the following general operating procedures for using these products with optimal performance.

Turn-On Procedure

- 1) With the RF input power turned 'OFF', make all necessary connections (i.e. RF cable, AC cable, DC cable).
- 2) Set signal generator to desired frequency and appropriate power level.
- 3) Turn 'ON' the RF input power from signal generator.
 - a. For Amplitude Modulation (ON/OFF): use TTL Mod. port (0-5V, up to ~ kHz)
 - b. For RF Attenuation: use UCA port (0V = full attenuation, 5V = no attenuation).

Turn-Off Procedure

- 1) Turn 'OFF' the RF input power from signal generator.
- 2) It is now safe to turn 'OFF' and/or disconnect all other equipment on user test bench.



SGX-M Test Port Power

Typical Test Port Power plots are provided on the following pages.

Test Port Power for WR-28 and WR-19

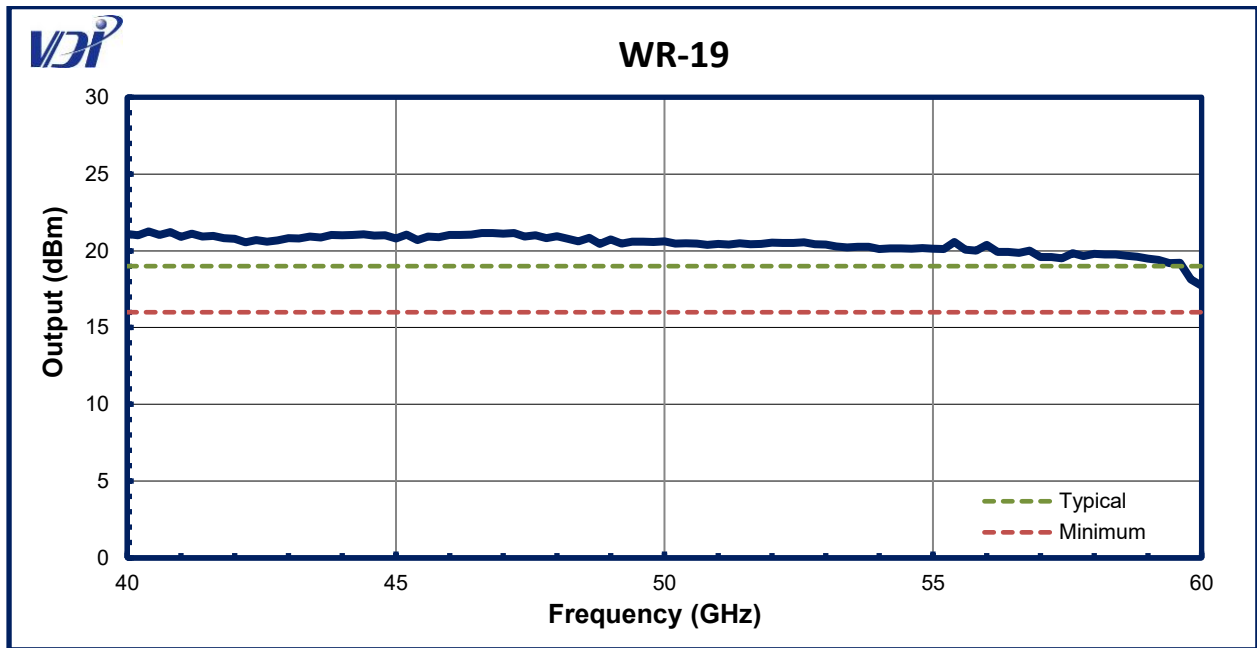
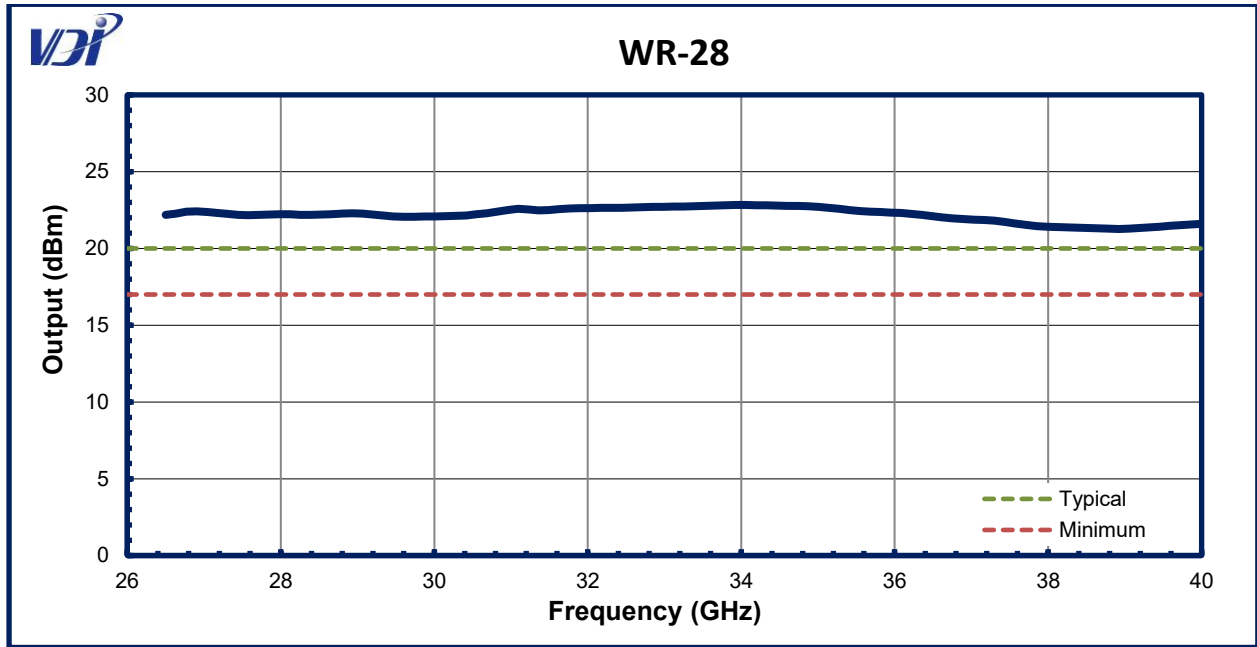

Test Port Power for WR-15 and WR-15 (SE)

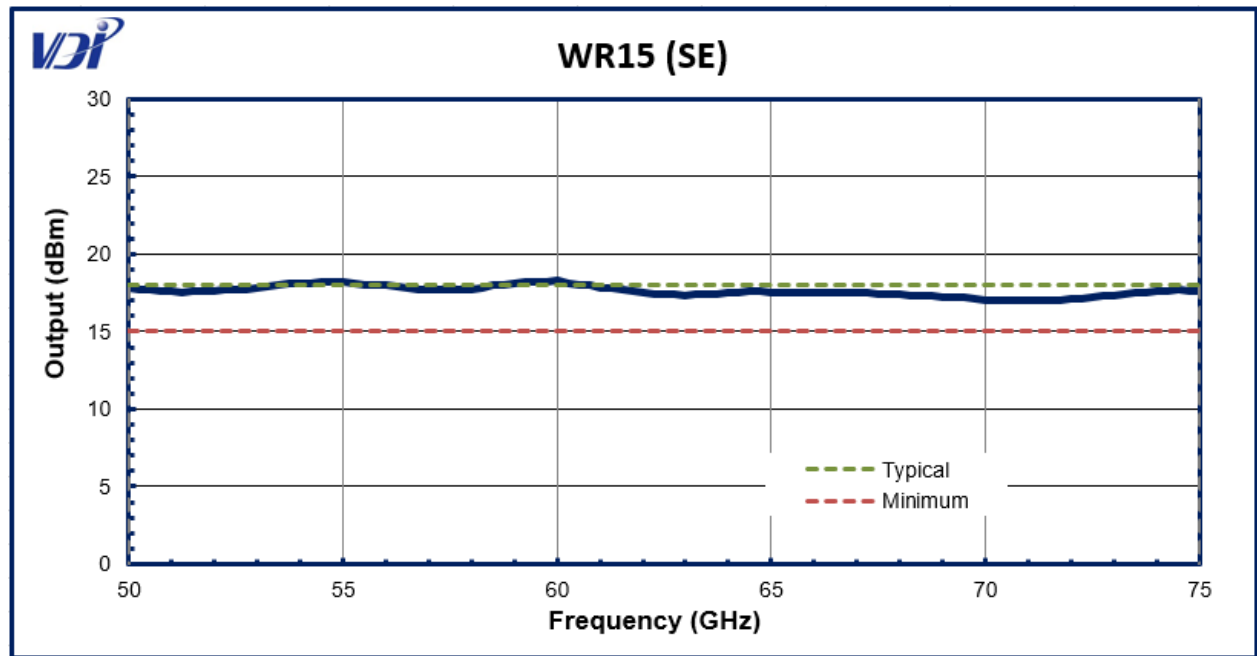
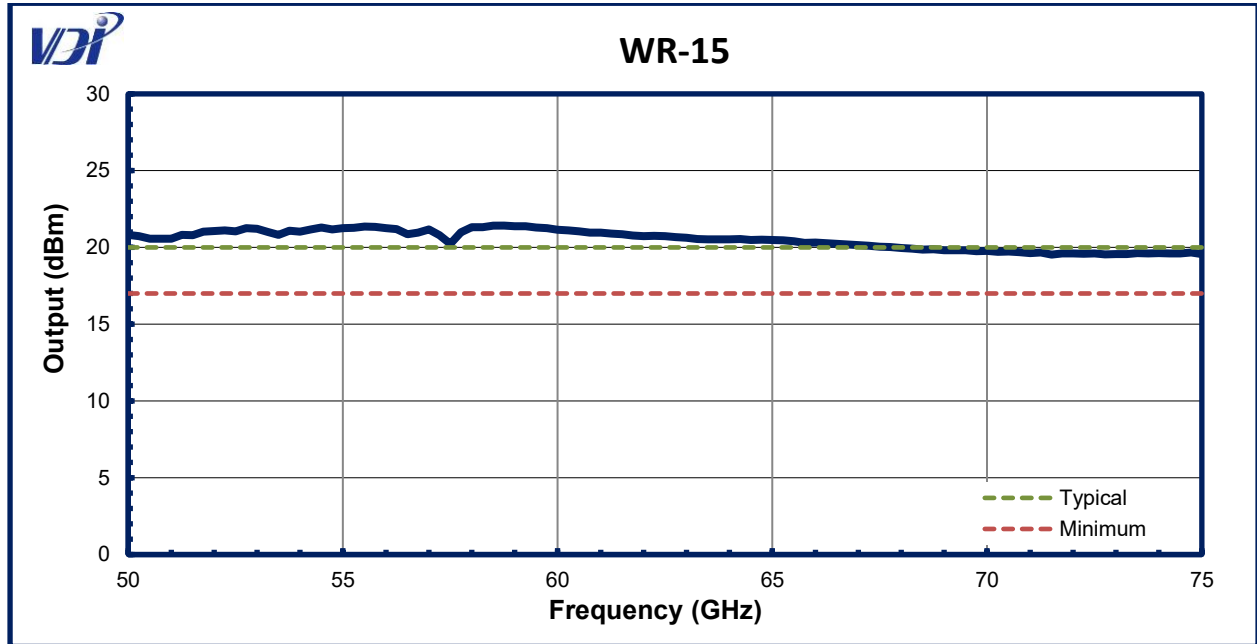

Test Port Power for WR-12 and WR-12 (SE)

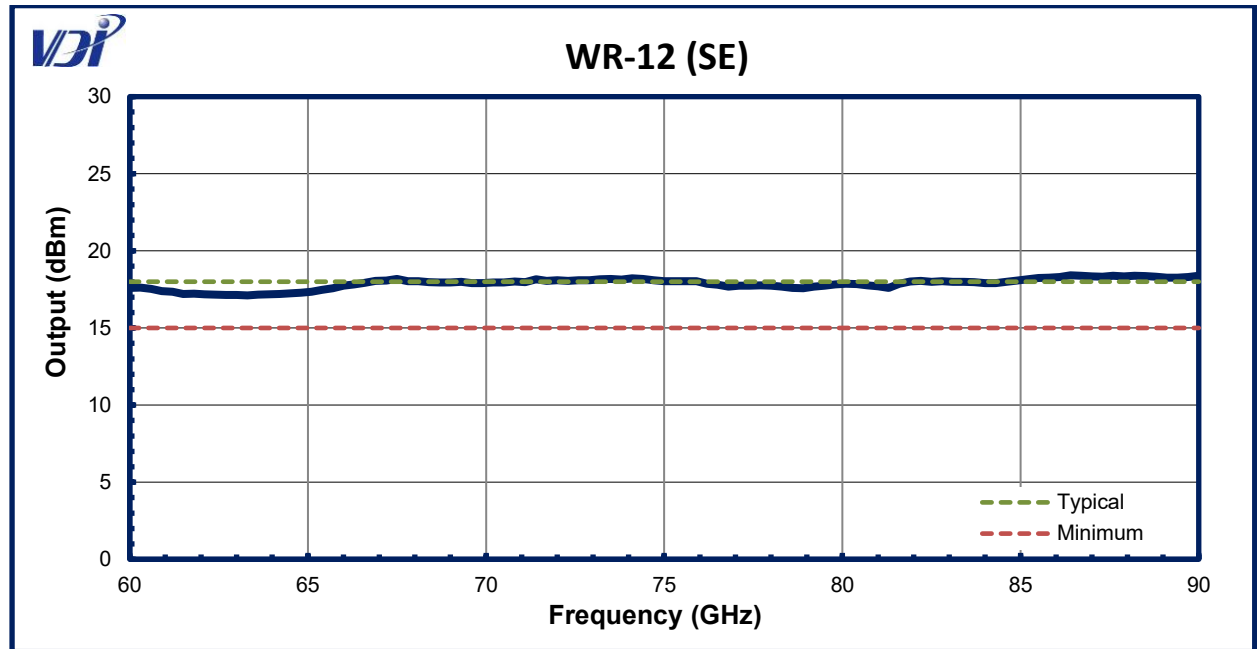
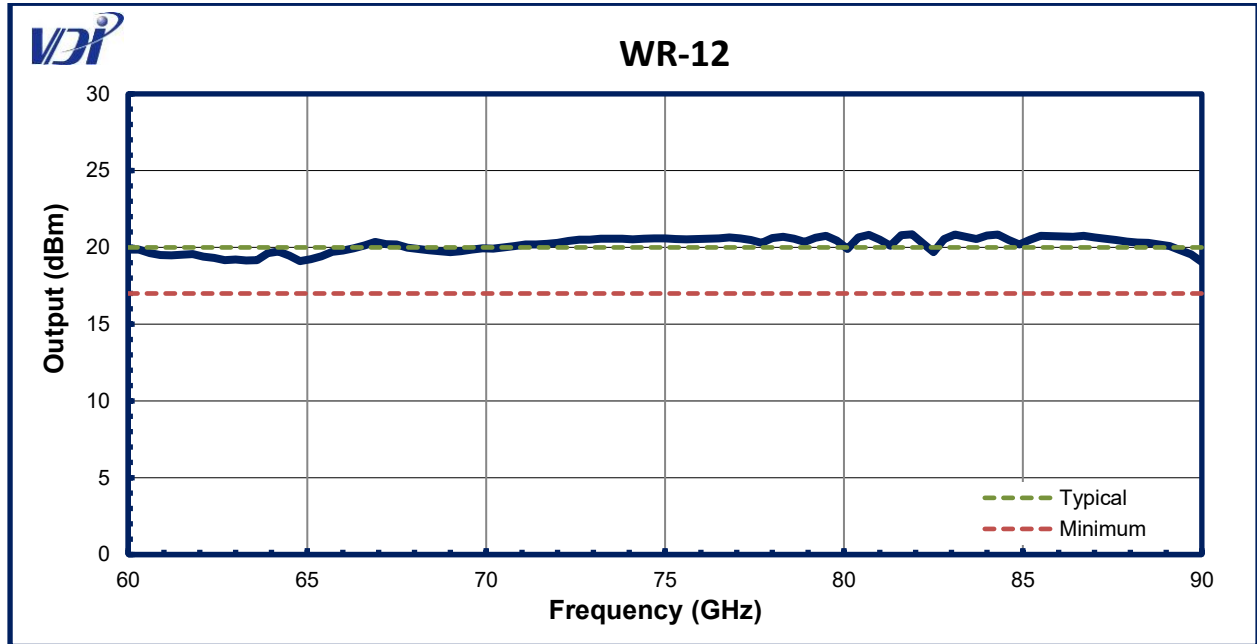

Test Port Power for WR-10 and WR-9

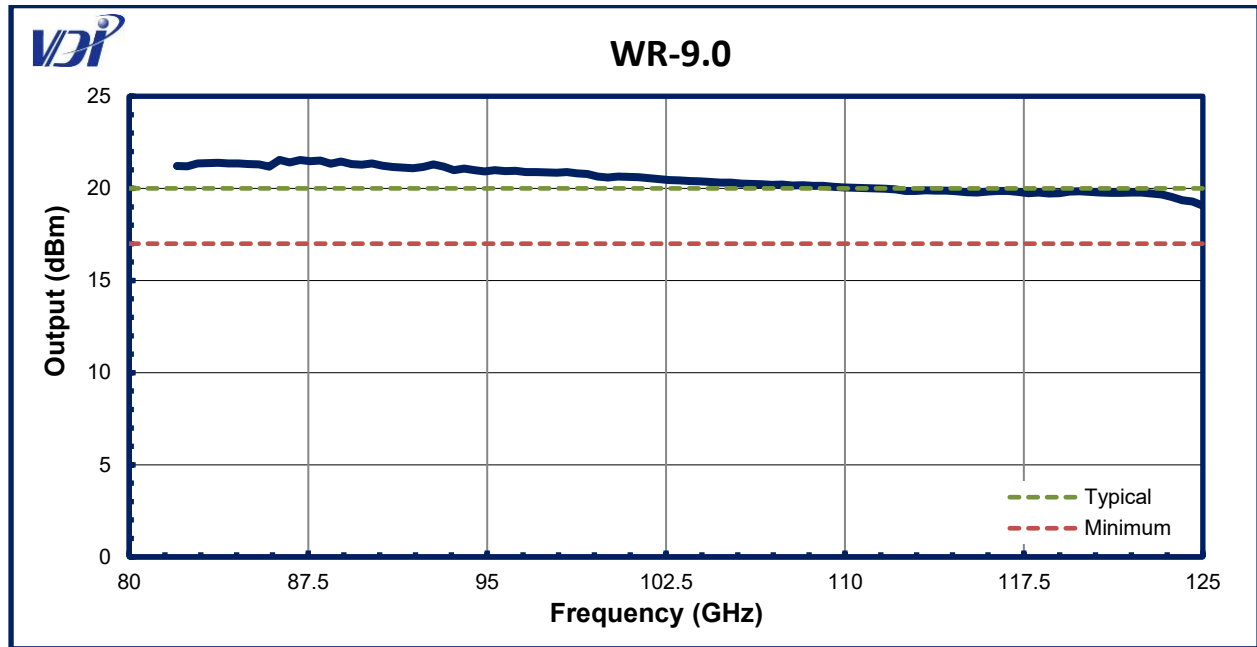
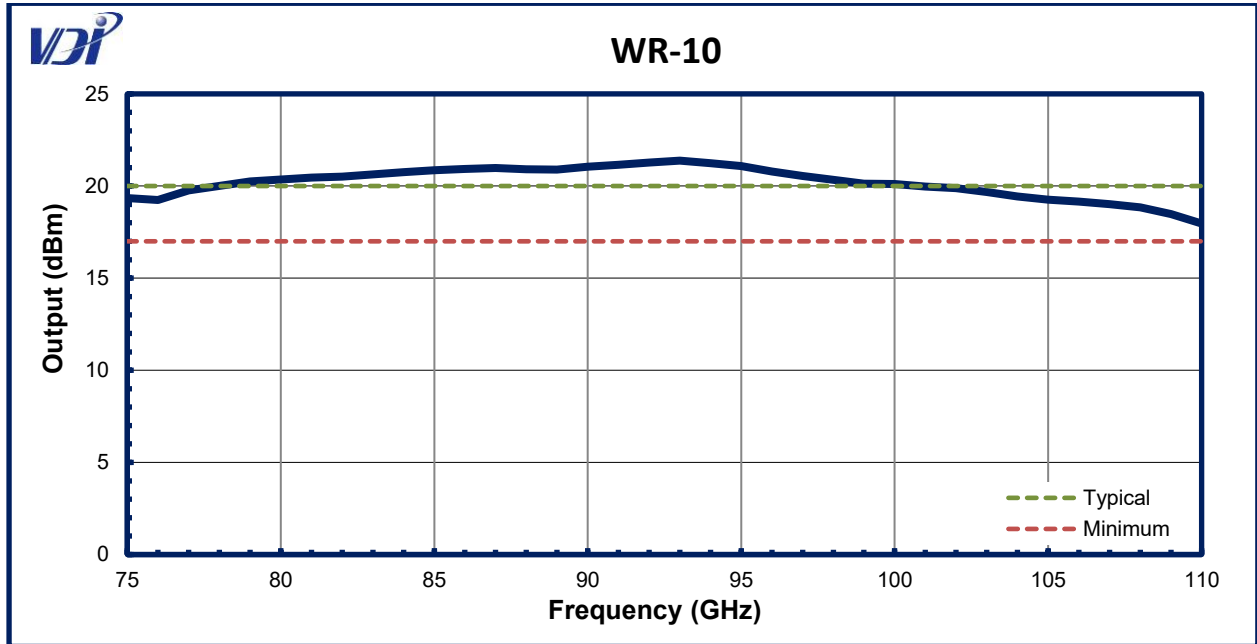

Test Port Power for WR-8 and WR-6.5

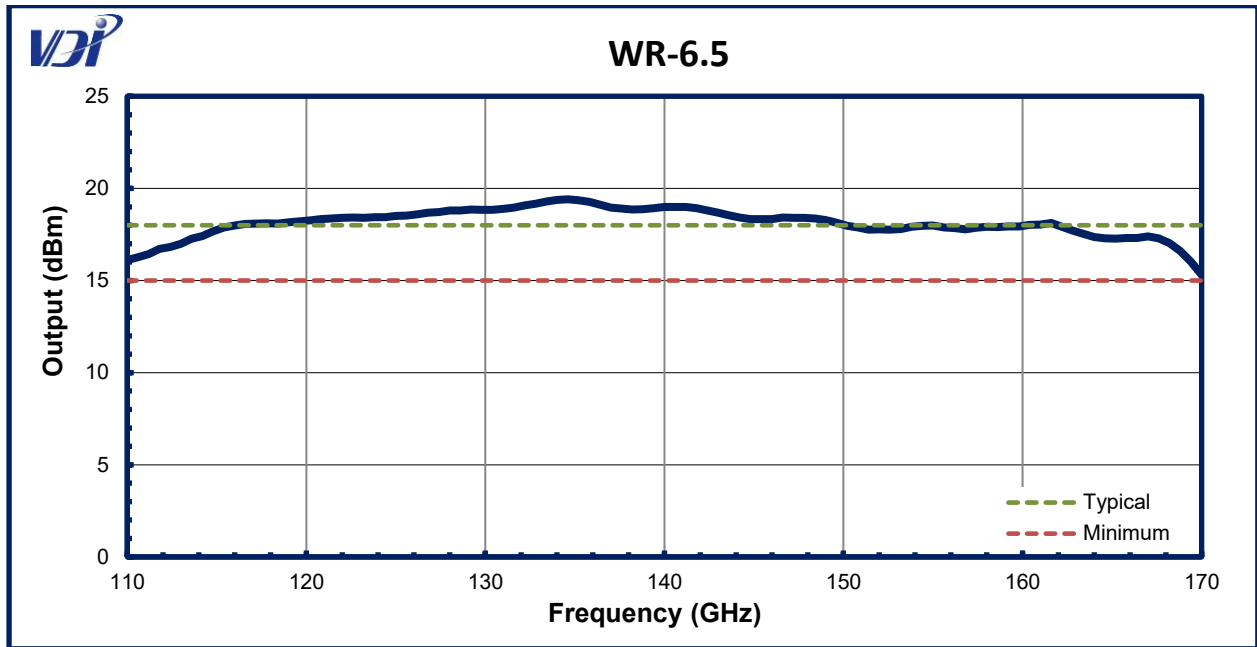
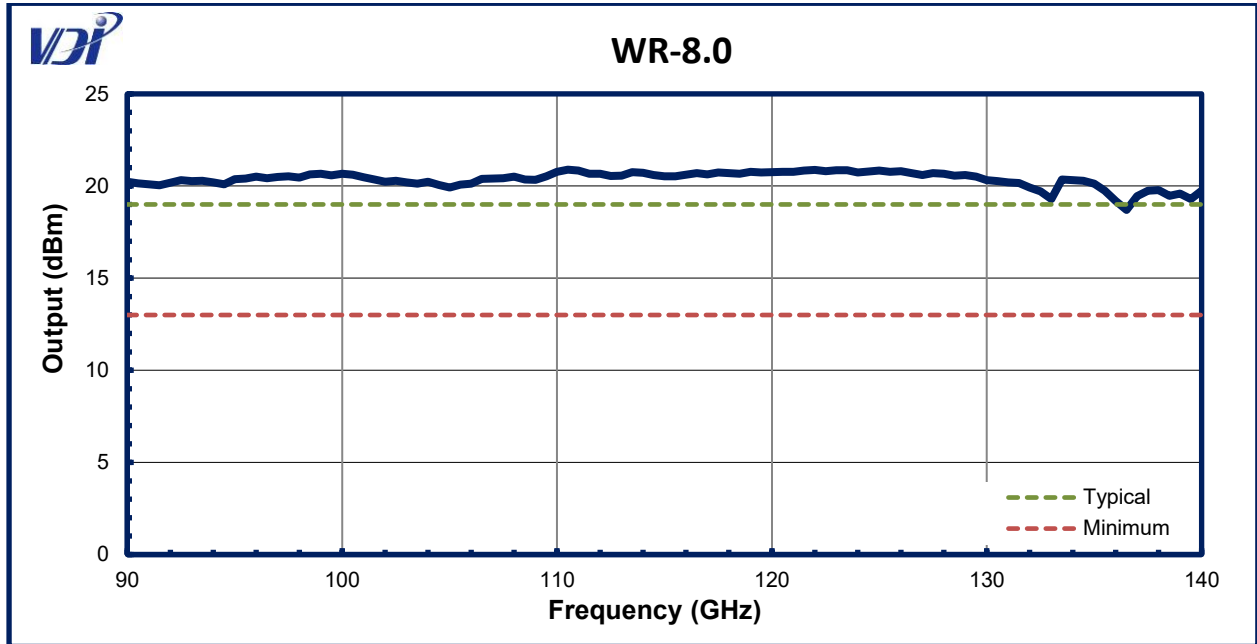

Test Port Power for WR-5.1 and WR-4.3

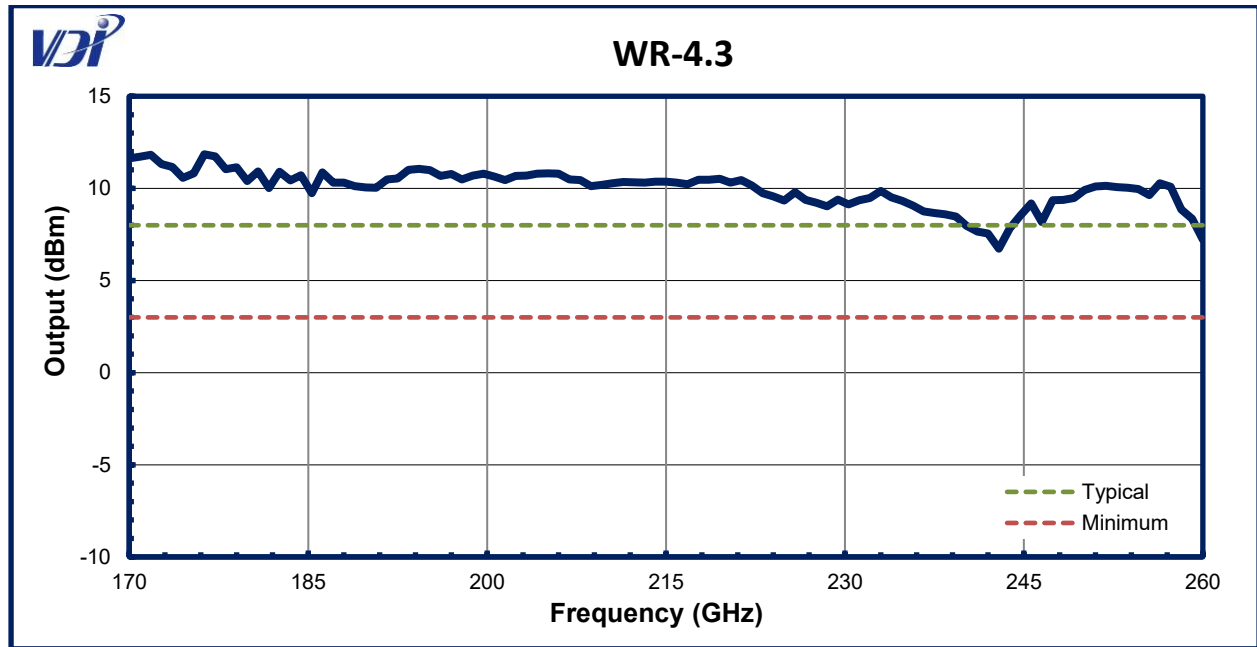
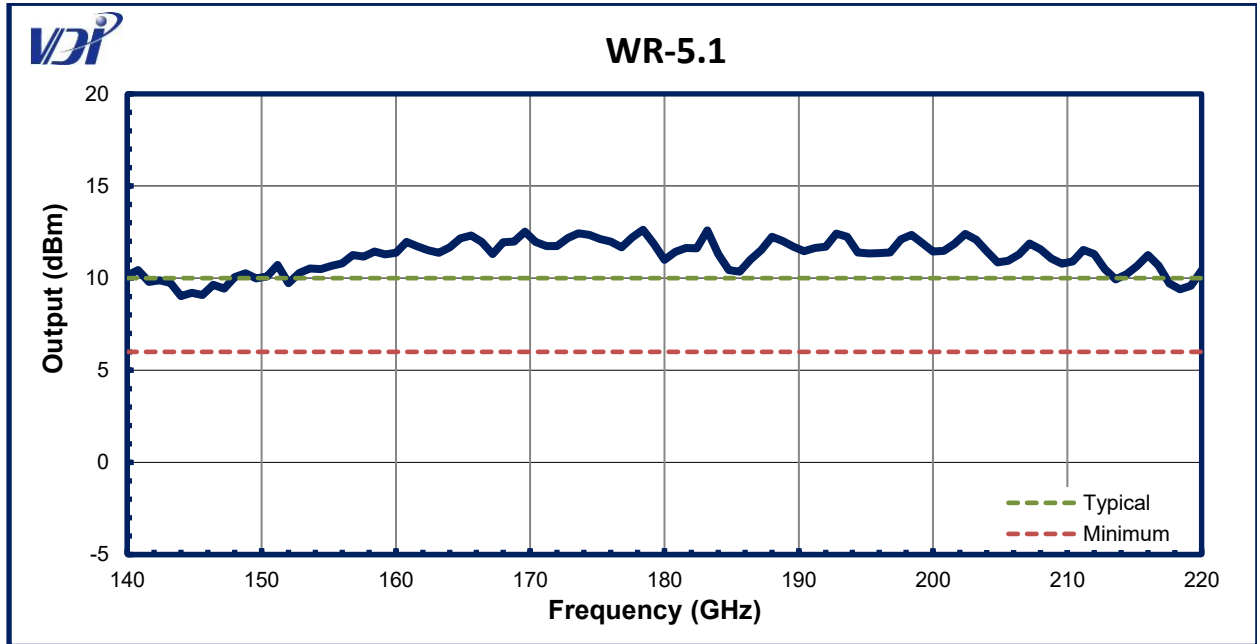

Test Port Power for WR-3.4 and WM-710 (WR-2.8)

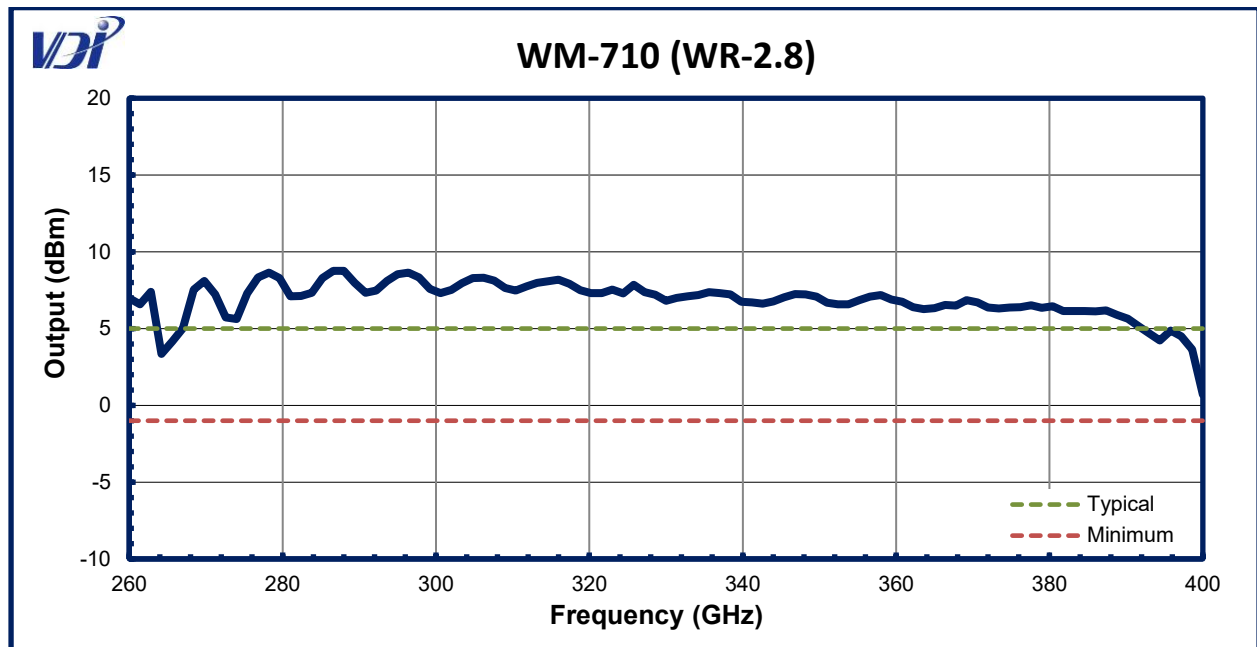
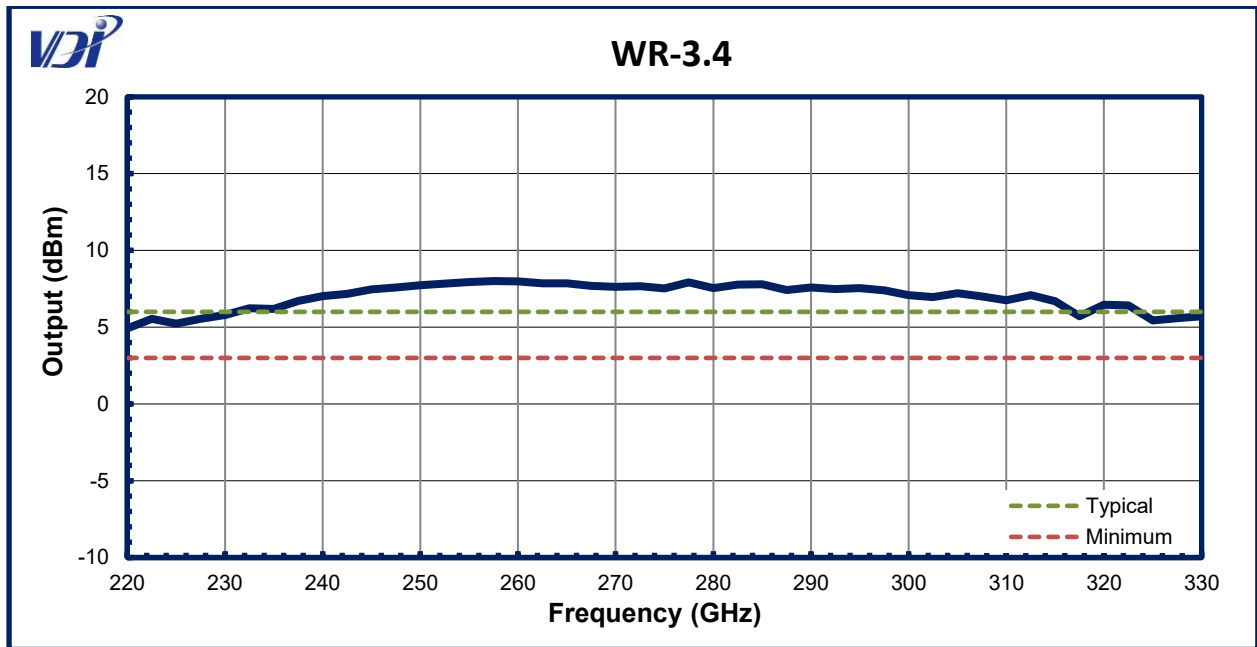

Test Port Power for WM-570 (WR-2.2) and WM-380 (WR-1.5)

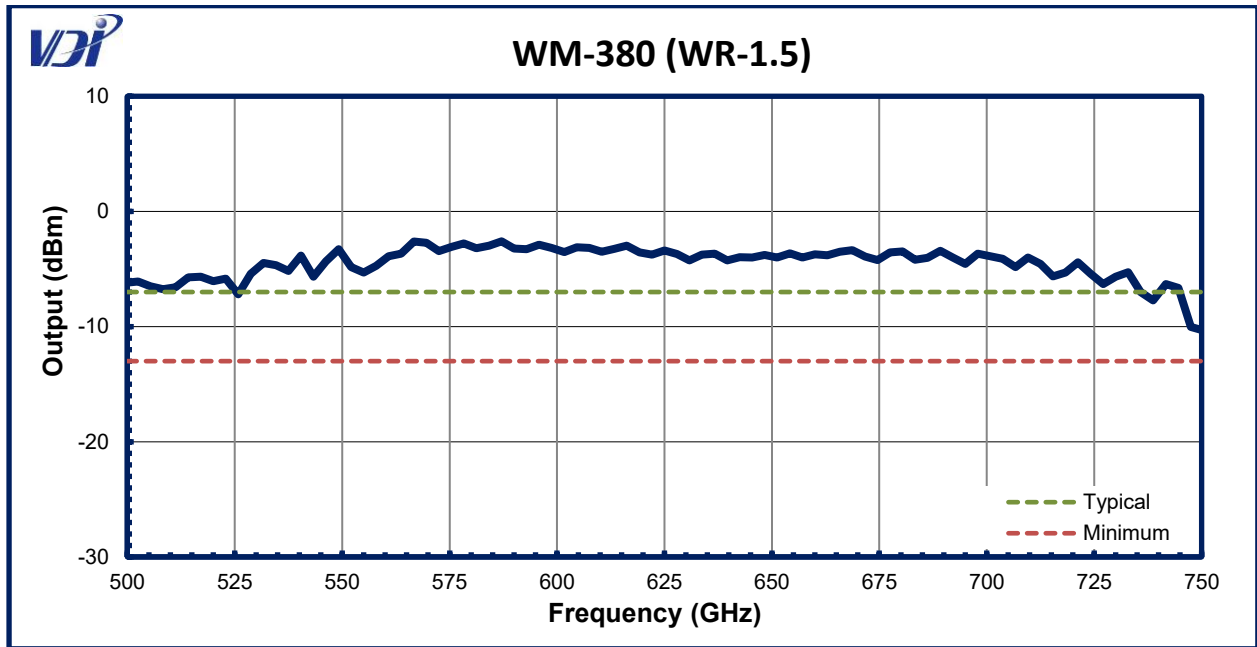
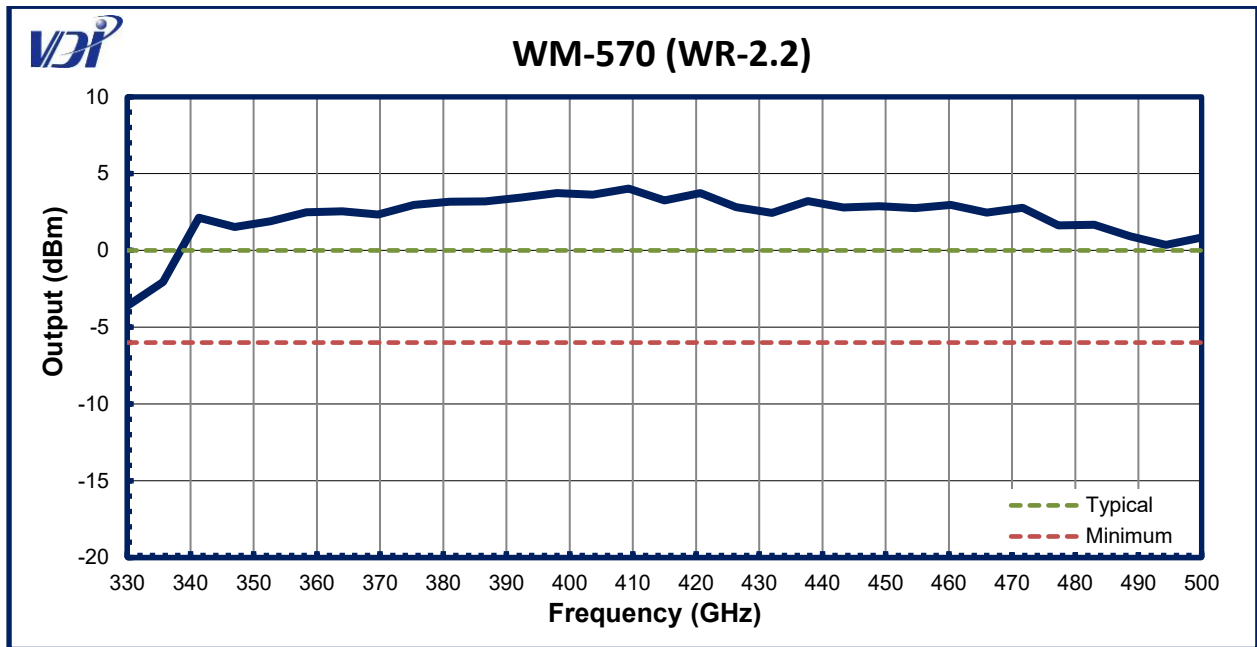

Test Port Power for WM-250 (WR-1.0)

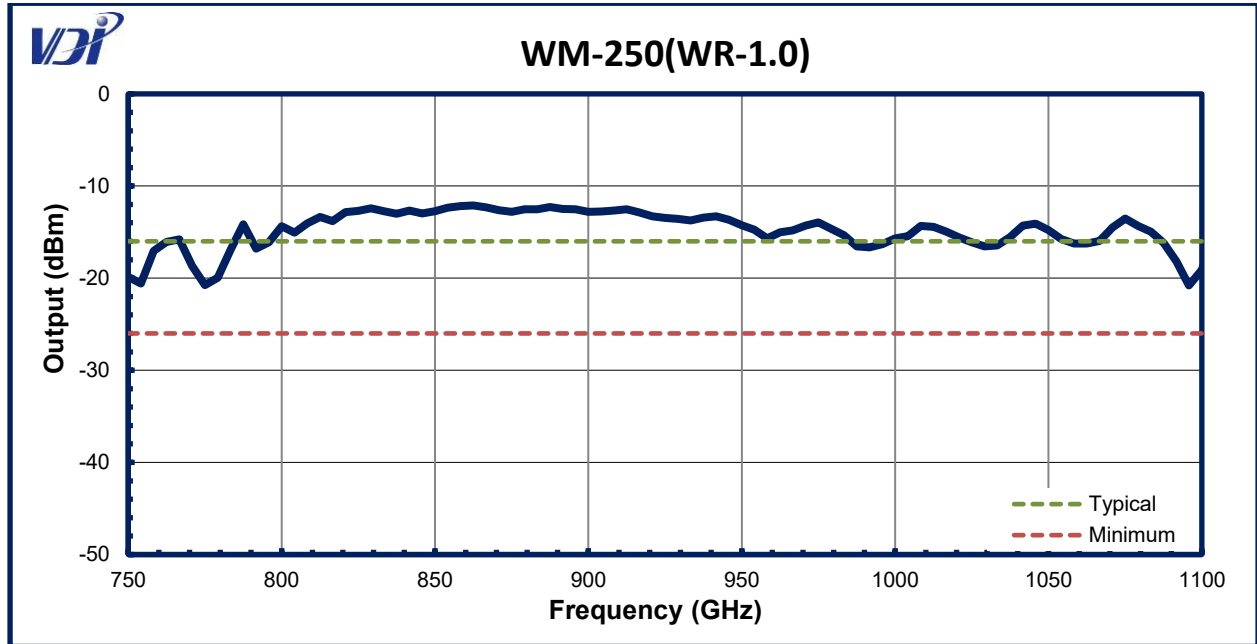

SGX-M – User Controlled Attenuation (UCA) Performance

Note: The UCA voltage reduces the module's output power. The UCA is only recommended by about 10dB and for higher values an external waveguide attenuator is recommended (see the Options List). The data presented in these graphs was measured by VDI under specific test conditions. These graphs are intended to be used as examples to show a module's nonlinearity and frequency dependence. The exact shape of the curves will vary significantly depending on the measurement conditions, including operating temperature, modulation rate, duty cycle, and load impedance.

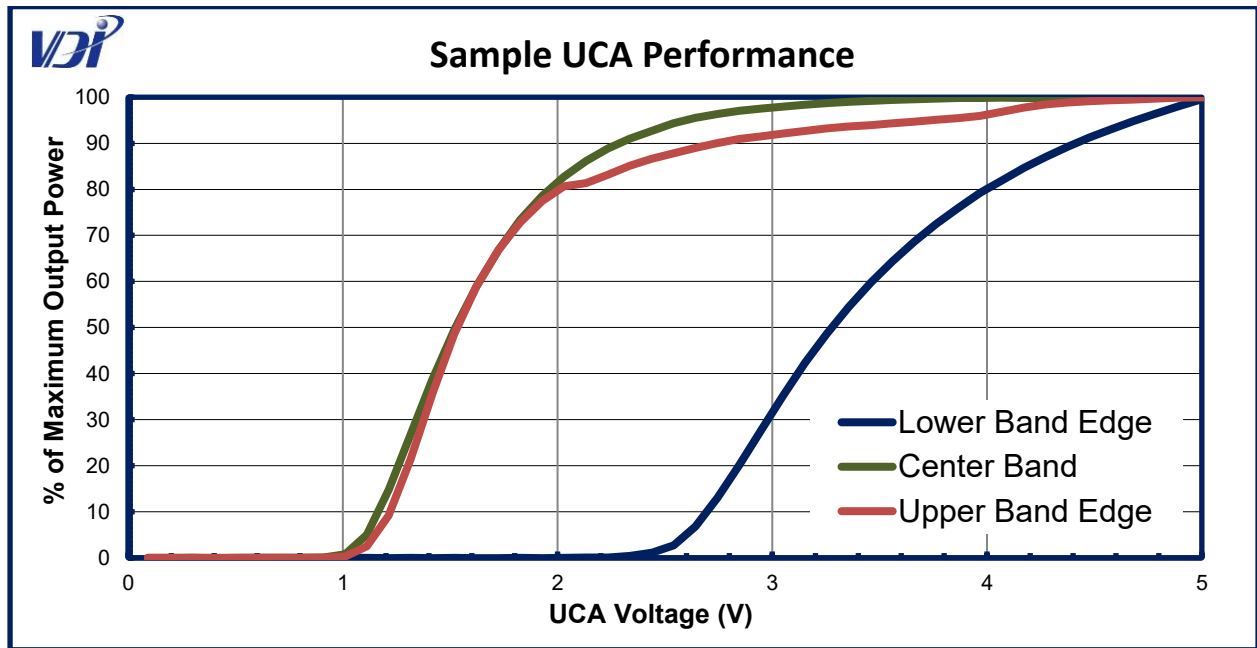
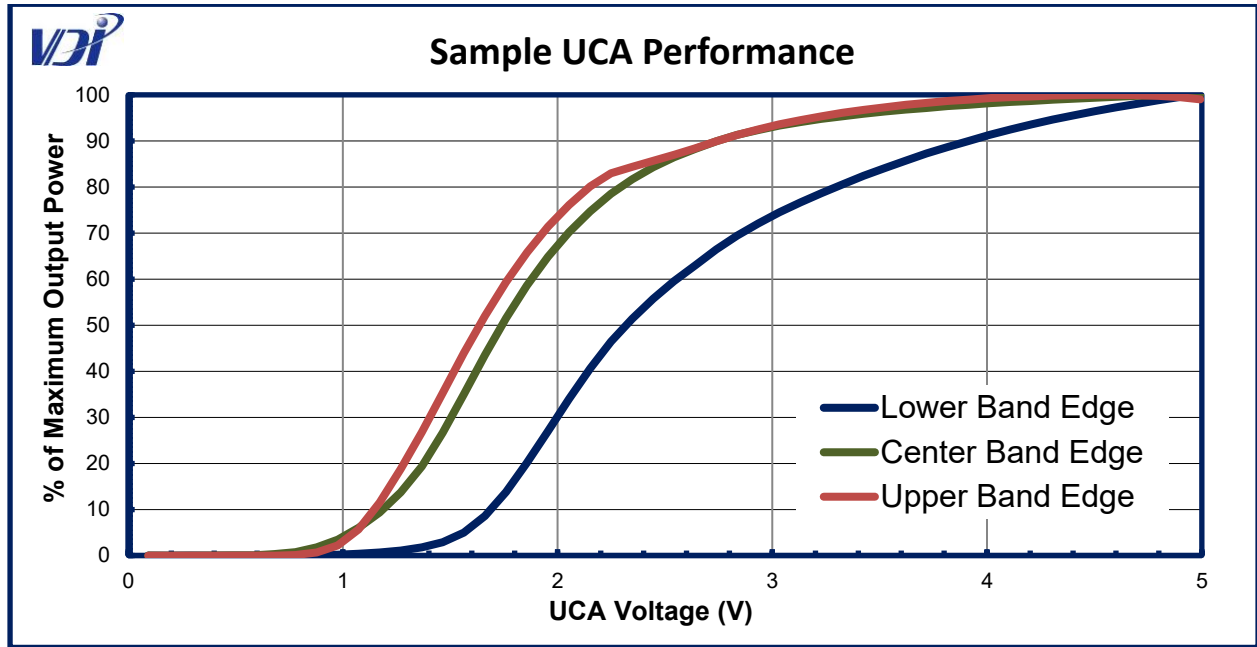

Cable Loss Characterization

Cable Loss Characterization Data

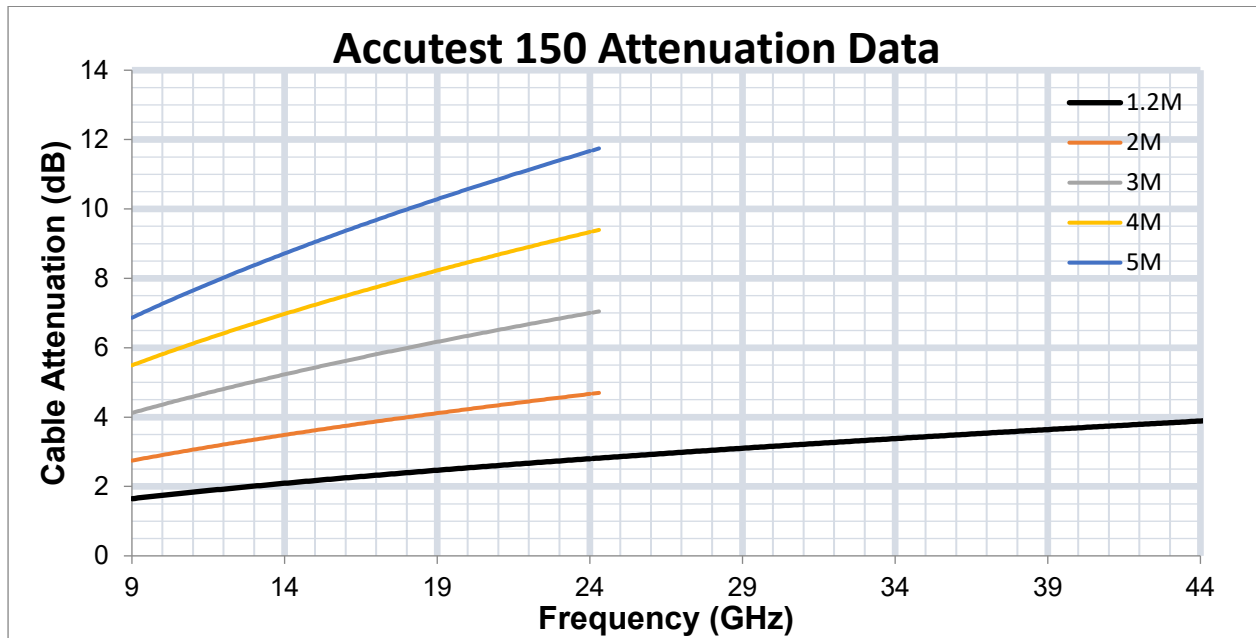

FIGURE 7 - ACCUTEST RF CABLE INSERTION LOSS

Typical insertion loss of Accutest 150 (RF Cable) with respect to frequency. This chart can be used to estimate cable losses in your system.



SGX-M Module Drawings

Mechanical Drawing – All SGX-M Modules

THE INFORMATION CONTAINED IN THIS DOCUMENT IS THE PROPRIETARY PROPERTY OF VIRGINIA DIODES, INC.

PART NUMBER:
VDIWR4.3SGX-M

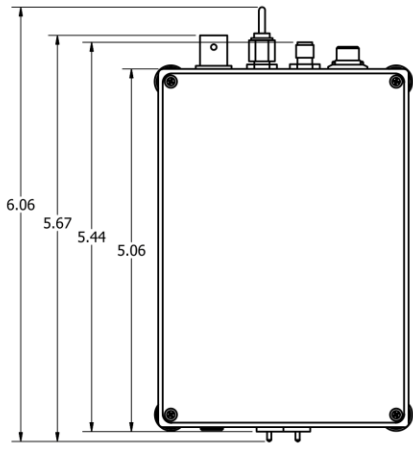

TOP VIEW

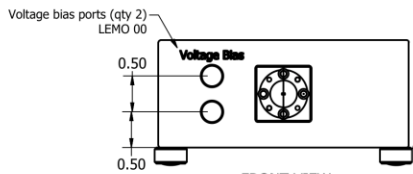
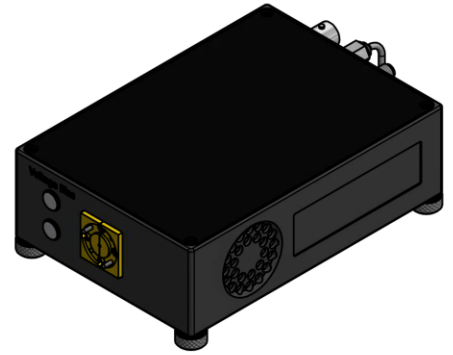
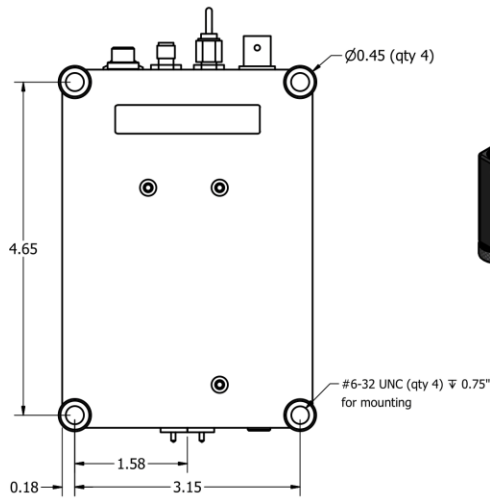

FRONT VIEW

Adjustable leveling mounts can be removed if desired

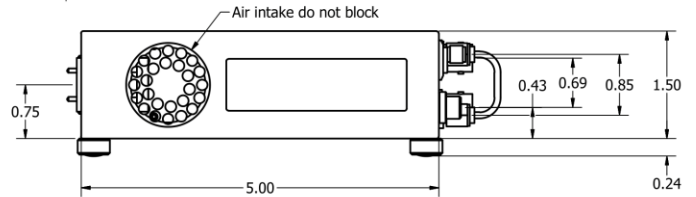

SIDE VIEW

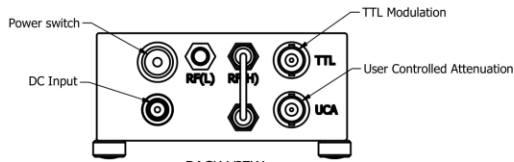

BACK VIEW

TITLE: VDIWR4.3SGX-M	MATERIAL: AS NOTED	SHEET: 1 OF 2		VIRGINIA DIODES, INC. 979 2nd ST. SE, SUITE 309 CHARLOTTEVILLE, VA 22902 PHONE: 434-297-3257 FAX: 434-297-3258 www.virginiadiodes.com
MODEL #: VDIWR4.3SGX-M	LAST REV. DATE: 10/25/2015	UNITS: INCHES		
	LAST REV.: 1			



Addendum – Product Updates and Company Contacts

Virginia Diodes' Mini Signal Generator Extension (SGX-M) modules provide high performance frequency extension of microwave signal generators into the THz range. VDI SGX-M modules offer full waveguide band coverage and are available from WR-28 (26.5-40 GHz) to WM-250 (750-1,100 GHz). Additional bands are under development. VDI modules combine high test port power with low phase noise to offer exceptional performance.

The Virginia Diodes staff of engineering and physical science professionals works to continually improve our products. We also depend upon feedback from colleagues and customers. Ideas to simplify extension module operations, improve performance or add capabilities are always welcome. Be certain that Virginia Diodes has your latest contact details including a phone number and an email address to receive update advisories.



Contact VDI:

Virginia Diodes, Inc.

Web: <http://www.vadiodes.com>

Email: Technical@vadiodes.com

Telephone: 434.297.3257

