



PM5 Operational Manual



979 Second Street SE, Suite 309
Charlottesville, VA 22902-6172 (USA)
Tel: 434.297.3257; Fax: 434.297.3258
www.vadiodes.com

Section 1 – Contents, New Benefits and Safety	Pages 2-3
Contents	Page 2
New Benefits / Safety: Read Prior to Activating Your PM5	Page 3
Section 2 – Control Descriptions, Specifications and Service	Pages 4-6
Front Panel / Rear Panel / Sensor Head Overview	Page 4
Front Panel / Rear Panel Operational Details	Page 5
PM5 Specifications and Service	Page 6
Section 3 – Starting and Operating the PM5	Page 7
Section 4 – Settlement Times and Drift	Page 8
Section 5 – Tapers / Horn Antennas / Flange	Page 9
Section 6 – Power Meter Response Times	Page 10
Section 7 – PM5 Software Guide, USB and GUI	Pages 11-13
Introduction and Software Startup	Page 11
GUI Control Buttons and Overview	Page 12
GUI Control Buttons' Detailed Functions	Page 13
Appendix 1 – Programming / Commands / Communications	Pages 14-18
Programming Communications and Commands to the PM5	Page 14
Communications and Protocols from the PM5	Page 15
Status Byte 1 / Status Byte 2 / Status Byte 3 Tables	Page 16
Response Return Format and Command Descriptions	Page 17
Set, Query and High Resolution Get Power Commands	Page 18
Appendix 2 – VDI's Power Correction Factors	Page 19
Appendix 3 – Key Component Mechanical Drawings	Pages 20-21
Sensor Head	Page 20
Waveguide Taper	Page 21
Addendum – Product Updates and Company Contacts	Page 22

New Benefits and Safety

Welcome to the PM5

Congratulations. You have chosen Virginia Diodes' PM5, an industry-leading solution for high frequency power measurement requirements. The PM5 is VDI's latest version of the Erickson calorimetric power meter and thanks to widespread industry acceptance, it has become the *defacto* standard for power measurement above 100 GHz. This highly accurate millimeter wave measurement tool is ideal for applications from 75 GHz to more than 3 THz. The PM5 supports power measurement ranges from 1 μ W up to 200 mW; it includes a WR10 sensor head and data collection software. A wide range of input waveguide tapers are available from VDI, making the PM5 a very flexible tool for high frequency applications. The PM5 delivers extremely wide bandwidth, excellent input match, low noise, high sensitivity and a USB interface powered by VDI's open source software for convenient operation and data collection.



New Benefits and Features

The new PM5 delivers lower noise, allowing for faster and more sensitive measurements. The PM5 also has a new auto scaling feature that allows for faster range changes and offers the flexibility of remote control through its new USB connection and software. Customer-designed software can also interface with the PM5 thanks to open source coding.

Safety



Read all instructions and information in this PM5 product manual before turning on or using your power meter. Start-Up & Operation procedures must be followed for proper function of the PM5. If you have questions contact VDI at 434.297.3257 before using your power meter.

- 1) Use of any attachments not authorized by VDI may void the PM5's limited warranty and could pose a hazard to the operator. Check with VDI before any measurement connection is attempted beyond the descriptions in this manual or if it may exceed commonly accepted standards of practice. (Tel) 434.297.3257 (Email) Technical@vadiodes.com.
- 2) The PM5 is intended for use with a grounded power supply; check with VDI if operational situations would utilize a different power source including free-standing generators.
- 3) Do not connect or disconnect either the AC power cable or the sensor cable while the meter is switched on.
- 4) Avoid strong vibration or shock to the sensor head; do not drop the sensor head on the floor or any other hard surface.

Virginia Diodes, Inc. (VDI) accepts no liability for damage or injury resulting from or caused by:

- Improper use or use for other purposes than those for which the PM5 was designed;
- Repairs carried out by persons other than VDI or its assigned agents;
- Tampering with or altering the power cord or sensor cable;
- Adjustment of machine components outside the parameters described in this manual.

Front Panel / Rear Panel / Sensor Head Overview

Front Panel



Rear Panel

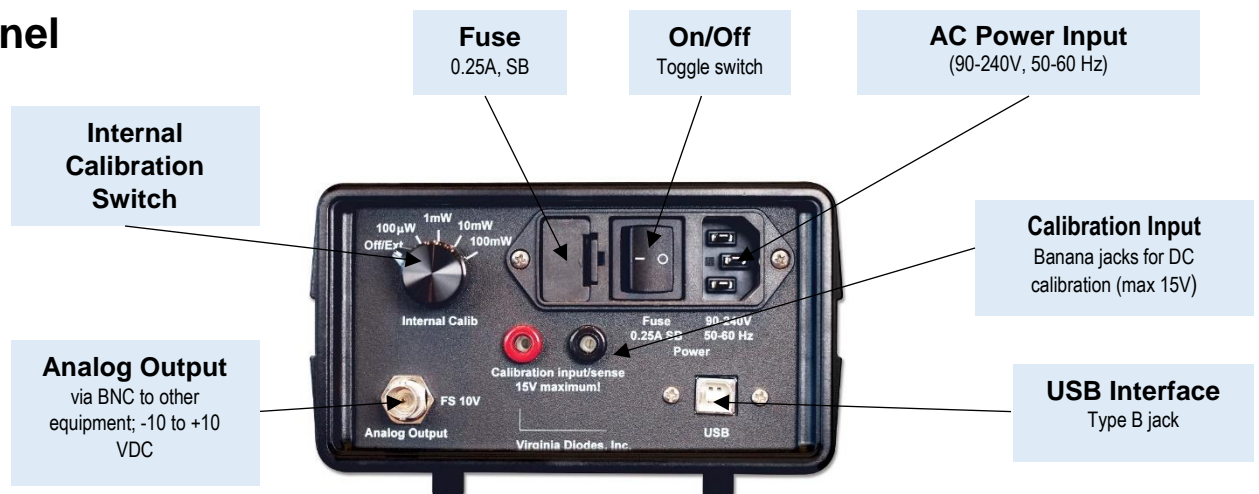

Sensor Head, Waveguide and Taper

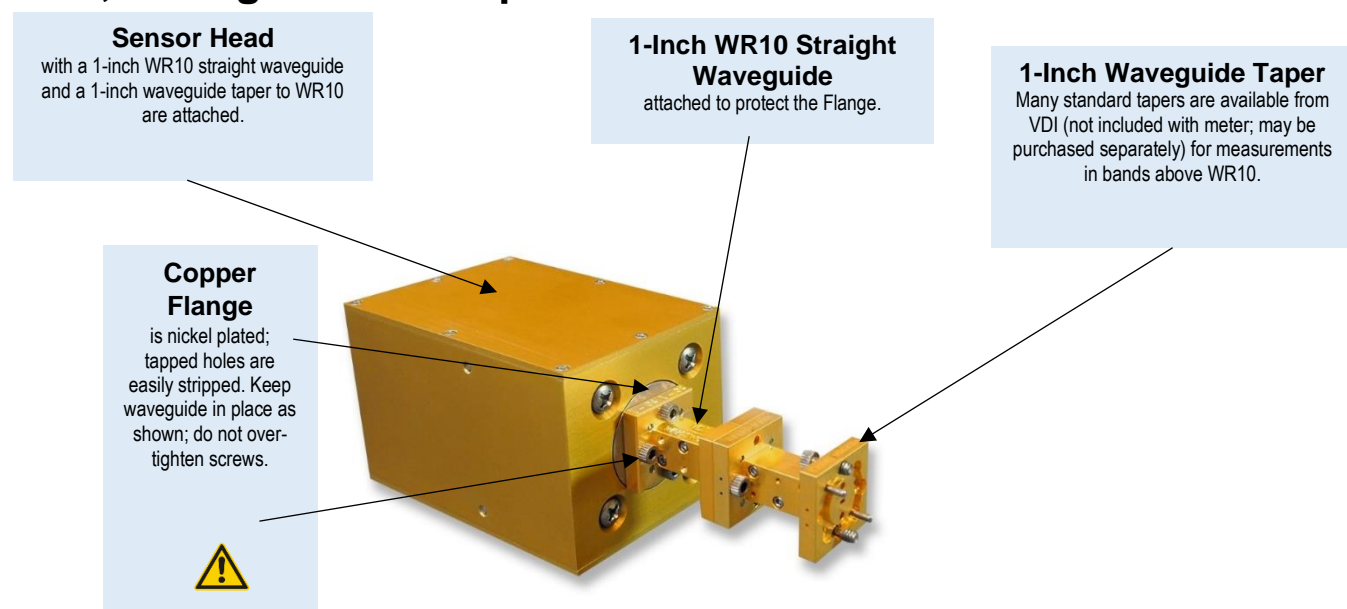

Front and Rear Panel Operational Details

Front Panel



Range Switch: Used to select fixed ranges of 200 μW , 2 mW, 20 mW and 200 mW. Also enables Auto Scale Mode and USB control when “Remote” is selected. The meter requires a relatively long wait for the thermal transients to settle; it settles more quickly when shifting ranges upward than it does when shifting ranges downward. Avoid going higher in ranges if you plan to immediately return to a lower range setting. See Section 4. Higher ranges have faster responses; using the highest range with sufficient resolution is recommended. The maximum measurable power for all ranges is limited to the full scale power (with 0 dB cal factor). Exceeding full scale power leads to a large imbalance in the normally closed loop and lengthy sensor recovery time.

Zero Button: Is used to zero the display with no effect on calibration. The meter will drift rapidly after turn-on and range switching; under some conditions it will drift slowly but steadily for several minutes. See Section 4. When in Auto Scale Mode the Zero Button has additional functionality: A) Press Zero Button once in any scale $>200 \mu\text{W}$ to turn on Range Hold; B) Press Zero Button twice (within 0.75 seconds) to turn off Range Hold; C) Press Zero Button three times quickly while in Auto Scale Mode in the 200 μW scale and the PM5 will simultaneously zero all four ranges. If the meter is over-ranged, pressing the Zero Button three times quickly will readjust internal settings for the active range to achieve full scale readings above the zero point, if possible. It is strongly recommended that the meter be allowed to settle before pressing the Zero Button three times quickly. **Note:** If possible, zero the power meter when the sensor head is connected to the device under test and the device under test is turned off.

Sensor Head Connector Port: This is a standard Amphenol connector, Series C091A, Part T3504001. Do not connect or disconnect the sensor cable if power is turned “On.” Contact VDI if you have questions about using longer cables.

Cal Factor Switch: Used for scaling the meter display to correct for input loss or gain; scaling applies only to the Front Panel Display and the GUI when measurement software is in operation via the USB. Scaling the meter does not affect the raw USB output or analog output. The switch reads in log (dB) units with 0 corresponding to no correction. Positive values correspond to correcting for input loss and negative values correspond to correcting for input gain. The maximum correction is ± 29.9 dB. The correction for the internal waveguide loss is only about 0.2 dB at 100 GHz. See Section 5 for details about using tapers and horn antennas. See Appendix 2 for a detailed description of WR10 SWG and taper frequency dependent insertion loss.

Rear Panel



Power Switch and Fuse: The power control is on the back panel since it is not expected that this instrument will be turned “ON” or “OFF” frequently. Do not turn the power switch from “ON” to “OFF” in quick succession because improper start-up may occur in some of the logic, which can lead to operational problems.

Best Practice: Wait at least 5 sec with the switch “OFF” before turning it “ON” again. The power entry module includes the fuse holder. The fuse may be removed by leveraging the tab on the plastic holder next to the Power Switch. The fuse rating is 0.25A “slow blow,” and measures $1\frac{1}{4} \times \frac{1}{4}$ inches.

Internal Calibration Switch: The sensor element may be heated with known amounts of DC power for examination of the thermal response. The Internal Calibration Switch may be used to apply powers of 0.100, 1.00, 10.0 and 100 mW to the sensor. Under remote control via the USB, calibration voltages may be turned “ON” and “OFF,” but only if the switch is set to any position except “OFF.”

Calibration Input via Banana Jacks: The rear panel banana jacks are buffered and therefore not connected directly to the sensor calibration heater resistor, which has a value of 1000 Ω . If you wish to check the calibration at other heat values you may apply any voltage up to 12.7 V to the banana jacks with the Internal Calibration Switch set to the “Off” position.

Analog Output: A BNC connector is provided to interface the meter to other equipment. It provides a linear output of -10 to +10 VDC, with +10 VDC corresponding to full scale power on each range and 0 VDC corresponding to 0 mW. The analog output data rate is 1 Hz on the 200 μW scale, 5 Hz on the 2 mW scale, 20 Hz on the 20 mW scale and 35 Hz on the 200 mW scales. Output impedance is ~ 0 ohms.

USB Port: This meter utilizes a USB (Type B port) interface to enable full control of the PM5 via the VDI software or customer-designed programs. The supplied flash memory stick contains an MS Windows graphical interface with the original Labview 7 code to set the scale, zero the meter, read the data, and write data to a log file at chosen intervals. See Section 7 for a Graphical User Interface (GUI) overview. A detailed programming guide is located in Appendix One.

PM5 Specifications and Service

Typical Specifications

- Input is WR10 waveguide (1.25 x 2.5 mm) with UG387 Flange. Useful frequency response is 75 GHz through the submillimeter range, extending even to the visible.
- Rear banana jack plugs provide a buffered connection to a 1 k Ω heater resistor (on the RF load), which is used for DC calibration. This connection enables internal calibration checks on all of the meter's ranges. Maximum response is up to 12.7 V. Absolute maximum is 25 V.
- RF accuracy is typically $\pm 5\%$.
- Maximum VSWR <1.15:1 in 80-110 GHz band. VSWR is expected to be similar or better at frequencies up to 2000 GHz.
- Input loss is <0.15 dB at 90 GHz.
- Analog output BNC connector on back panel: -10 to +10 VDC, with +10 VDC corresponding to full scale power on each range and 0 VDC corresponding to 0 mW.
- A USB (Type B) port is provided for full instrument control.
- Temperature drift is compensated to <2 $\mu\text{W}/^\circ\text{C}$.
- Auto Scale Mode allows for relatively rapid range changes (~30 seconds) compared to the normal ranges. The range will change automatically based on input power.
- Operational temperature range: 10-30 $^\circ\text{C}$.
- Required power: 90-240 V / 50-60 Hz.

Typical Performance

Scale (FS)	Time for 90% Response*	Analog/Digital Update Rate	RMS Noise (USB out)	Display Update Rate	RMS Noise Display
200 mW	0.15 s	35 Hz	0.5 μW	4 Hz	~0.2 μW
20 mW	0.2 s	20 Hz	0.2 μW	2.5 Hz	~0.08 μW
2 mW	0.6 s	5 Hz	0.04 μW	2.5 Hz	0.03 μW
200 μW	12.0 s	1 Hz	0.003 μW	1 Hz	0.003 μW

***Figure 1:** Response time is given as the time from application of an input to a response at the analog output of 90% of the final reading. Specifications are typical for changes in power greater than 0.075% of full range.

Servicing the PM5

Call 434.297.3257 for service details or email VDI at: Technical@vadiodes.com.



Careful review of the instructions in the “ReadMe” file on the flash memory drive included with your new PM5 is recommended. It is critical that all instructions are followed for downloading files onto your computer before connecting the computer and meter via a USB cable. Call VDI at 434.297.3257 with any questions prior to: connecting the power supply or a computer to the PM5, or starting the meter.



1. Follow installation instructions on the “ReadMe” file that was provided on the USB memory drive you received with your new PM5 meter.
2. If remote operation is desired, be sure to install the VDI-provided software BEFORE proceeding.
3. With the PM5 Power Switch (rear panel) in the “OFF” position, connect one end of the sensor cable to the front panel port of the PM5 readout; connect the other end to the PM5 sensor head.
4. Connect the AC power cable to the rear panel of the PM5 in its three-prong AC input socket.
5. Connect the USB cable to the USB port (Type B) on the back panel of the PM5; connect the opposite end of cable to a compatible USB port on the computer to be used in conjunction with the PM5. (Optional)
6. Turn on the PM5 by flipping the power switch to the “ON” position: ‘—’ = “ON”; “O” = “OFF.”
7. Do not rapidly toggle between “ON” and “OFF” settings as this will temporarily cause inaccurate meter readings. Maintain an “ON” or “OFF” setting at least 5 seconds before switching to the opposite setting.
8. Turn the Range Switch knob on the front panel of the PM5 to a selection appropriate for the power measurement. If you plan to make a number of measurements across increasingly higher power levels, begin with the lowest level, then proceed to higher settings.
9. Allow enough time for PM5 to settle; see PM5 Product Manual for **Settlement Times and Drift**, located in **Section 4**.
10. See PM5 Product Manual concerning **Use of Tapers in High Frequency Measurements**, located in **Section 5**.
11. Review conditions affecting **Power Meter Response Times**, located in **Section 6**.
12. See additional information detailing **PM5 software**, the **USB** and **GUI**, located in **Section 7**.

Modes of Operation: Range Switch Selections

Fixed Range Mode: Fixed Range Mode can be entered by setting the Range Switch to 200 μ W, 2 mW, 20 mW, or 200 mW; the setting selected reflects maximum measurable power for a given range. Drift (see Section 4) and Response Time (see Section 6) should be considered when choosing a range. Fixed Range Mode can also be controlled via the USB when the Range Switch is set to “Remote.” When in “Remote” the virtual Range Switch displayed in the GUI operates as described above. Custom program ranges can also be set by sending the appropriate command via the USB (see Section 7).

Auto Scaling Mode: Auto Scaling Mode is entered automatically when the Range Switch is set to “Remote” and can be fully controlled via the USB (see Section 7). It is generally used to rapidly switch between fixed ranges with much shorter settling times. This mode of operation has four ranges like Fixed Range Mode; however, in Auto Scaling Mode they become 200 μ W auto, 2 mW auto, 20 mW auto, or 200 mW auto. When Range Hold is “OFF” the instrument automatically adjusts range based upon input power.

Range Hold: This feature fixes the range of the instrument and can be turned “ON” or “OFF” when in Auto Scaling Mode in any of the three upper ranges (2 mW auto, 20 mW auto or 200 mW auto). Turn “ON” by pressing the Zero Button while in an upper range (2 mW auto, 20 mW auto or 200 mW auto); turn “OFF” by pressing the Zero Button twice within 0.75 seconds. The Range Hold feature can also be cycled “ON” or “OFF” via the USB by using VDI software (see Section 7), or by sending the appropriate command via the USB in a custom program.



Range Switch

Select full-scale ranges from 200 μ W to 200 mW. ‘Remote’ enables USB control and auto range-scaling; virtual controls are viewable on the GUI.

The sensor is sensitive to small internal temperature gradients; measurements as indicated in the Display will drift slowly in response to many influences, but this drift is small. Typical drift level does not usually exceed $\sim 50 \mu\text{W}$ under normal conditions and is frequently much less.

Each power range selectable on the Front Panel of the PM5 is tuned to operate as fast as possible with acceptable noise and drift. Higher scales have faster responses, so it is recommended to use the highest scale with sufficient resolution. Switching ranges upward is practical with short settling times. Switching from higher to lower power ranges requires a longer wait for the thermal transient to settle. Switching more than one position downward requires a longer time to settle; it is recommended to avoid going up in scale if you plan to immediately return to a lower scale. After switching ranges from high to low (particularly from 200 mW to 200 μW), the sensor will drift for one to two hours. This drift will be slow enough to permit use within 10-15 minutes. A complete settling to the original zero may take a few hours.



The sensor also drifts in response to ambient temperature. This drift is partially compensated during manufacture, but the residual drift is $\sim 2 \mu\text{W}/^\circ\text{C}$. Higher drift may be seen due to ambient temperature variation if the temperature changes too fast for the sensor to stay in full equilibrium; full equilibrium takes over one hour to achieve under such conditions. Significant drift and zero offset can be induced by physically rotating the sensor head.

A noticeable source of apparent drift is due to the wideband response of the sensor. The sensor response band extends from 60 GHz to at least the visible spectrum, and so it responds to thermal emission from any object. Viewing an object only a few degrees warmer than the surroundings produces a response.

When measuring very low power levels (below 10 μW), it is essential that the sensor be connected to the source for at least a few minutes with the source "OFF" to establish the zero level. With the meter stabilized and zeroed, turn on the source without disturbing the connection to the sensor. If the source produces significant heating when "ON," this can still produce a response that mimics output power in two different ways: first, through simple thermal conduction down the connecting waveguide; second, through wideband thermal emission. It is critical when measuring low power levels to be sure you are not measuring a simple heating effect.

When measuring power levels $< 10 \mu\text{W}$, the following procedure is recommended:

1. Allow the meter to stabilize;
2. Make a base measurement with no RF power applied to the sensor;
3. Apply RF power to the sensor;
4. Wait an appropriate amount of time determined by the range of the meter and accuracy required (see Section 6);
5. Take the power measurement;
6. Calculate the difference between this power measurement and the baseline measurement, this is the detected power;
7. Repeat this procedure and average the detected power as necessary.

Tapers and their Role in High Frequency Measurements

When measuring signals of frequencies higher than the WR10 waveguide band, but within standard higher bands, best accuracy is obtained by inserting a linear waveguide taper between the source and the meter input. Such tapers between WR10 and all higher bands are available as standard microwave components from VDI, and typically have a length of about 1 inch. These tapers need not be very long or optimally shaped for low mode conversion, since the sensor load responds well to higher waveguide modes.



Using Horn Antennas

For free space beams at any frequency, a gradually flared horn (beginning with WR10) should couple radiation into the sensor waveguide with good efficiency. Within the WR10 band the horn must precisely match the beam properties since the waveguide carries only one mode in band. At much higher frequencies, the horn should be sized so that the aperture is somewhat larger than the expected beam size, and a precise beam match is not needed, since the waveguide can carry several modes. DO NOT use a horn tapering down to single mode size, and then a taper up to WR10, since this adds greatly to the waveguide loss, and makes mode matching much more critical.

Flange Details



The UG387 waveguide Flange is nickel plated copper and its tapped holes can be stripped very easily compared to waveguide parts constructed of different metals. Repair of the waveguide Flange is difficult once threads are damaged. Do not over-tighten these screws since this leads to progressive thread damage. There is no advantage to tightening these screws beyond initial snug contact between flanges. VDI has supplied a 1" section of WR10 waveguide to help prevent damage to the sensor Flange. VDI recommends the use of this section for all measurements. Please see information about tapers at the top of this page and Appendix Two: "VDI's Power Correction Factors."

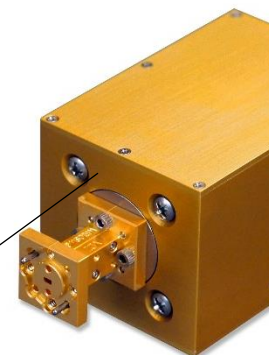

Caution

Tapped holes in the nickel plated copper waveguide Flange can be easily stripped.

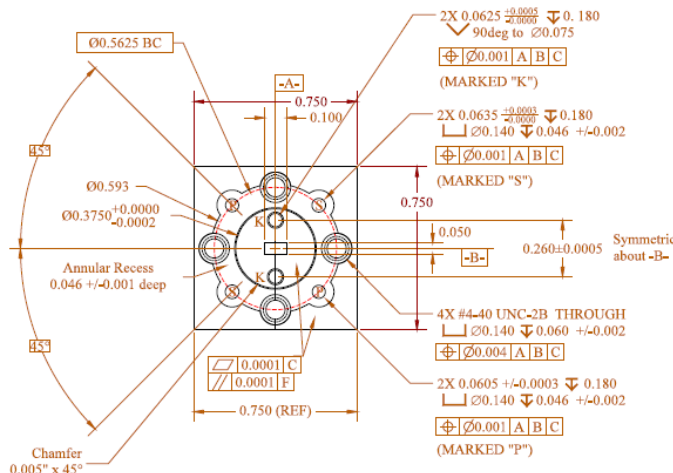

Figure 2:

Interface Flange for 1-inch and 2-inch waveguides. WR10 waveguide is shown above. All dimensions are in inches.

The following plots show the actual response of a sensor measured at 90 GHz. The response is not a simple exponential. It instead shows evidence of multiple time constants. It takes more than twice as long to reach 99% of the final measured response than it does to reach 90%. For the most consistent and accurate measurements, wait the 99% response time given in the figures below.

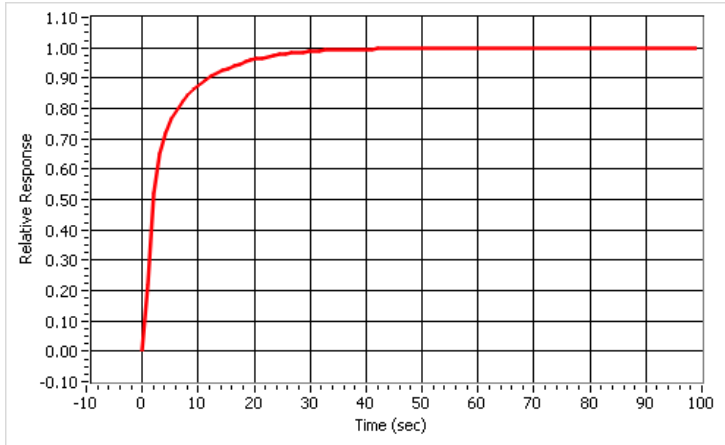

Figure 3:

Response on the 200 μ W scale. 90% response is at 12 sec. while 99% is at 31 sec. After 60 sec. the reading changes insignificantly.

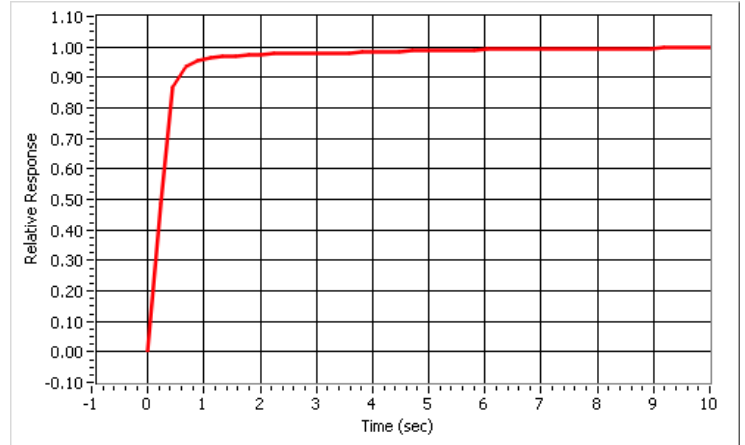

Figure 4:

Response on the 2 mW scale. 90% response is at 0.6 sec. while 99% is at 5 sec. After 8 sec. the reading changes insignificantly.

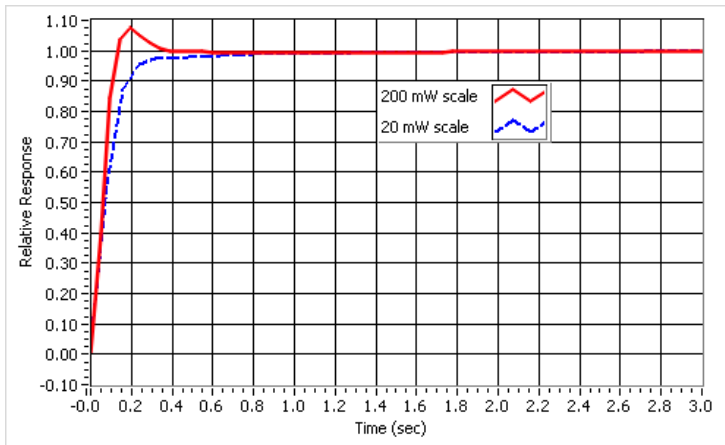

Figure 5:

Response on the 20 mW and 200 mW scales. After 3 sec. the reading changes insignificantly. Response settled to 99% is at 1.0 sec. for 20 mW and 0.4 sec. for 200 mW. The overshoot amount varies with sensor, and is not observable on the front panel Display because it averages 8 individual readings of the USB port.



The PM5 has a USB interface that can be used to control all meter functions. Be sure to review the “ReadMe” file contained on the flash memory drive provided by VDI with your PM5. PM5 program files can be downloaded from the [VDI website](#). The Graphical User Interface (GUI) is Windows based.

- 1) The flash drive should autorun program installation;
- 2) If the program does not auto-load, run “setup.exe”;
- 3) Connect the power meter to the computer to be used for all measurements and data collection using a USB (Type B) cable at the meter and requisite connection jack for your computer;
- 4) Next, turn on the power meter, so that the drivers may be automatically loaded;
- 5) Run “PM5.exe” installed during setup in the installation directory. Doing so will open the window shown in Figure 6;
- 6) Enter the serial number found on the sensor head in the “SN#” field. Default is 235V;
- 7) Run the program by clicking on the arrow in the top left corner;
- 8) Clicking the Run Continuously button from “ON” to “OFF” will stop the program.

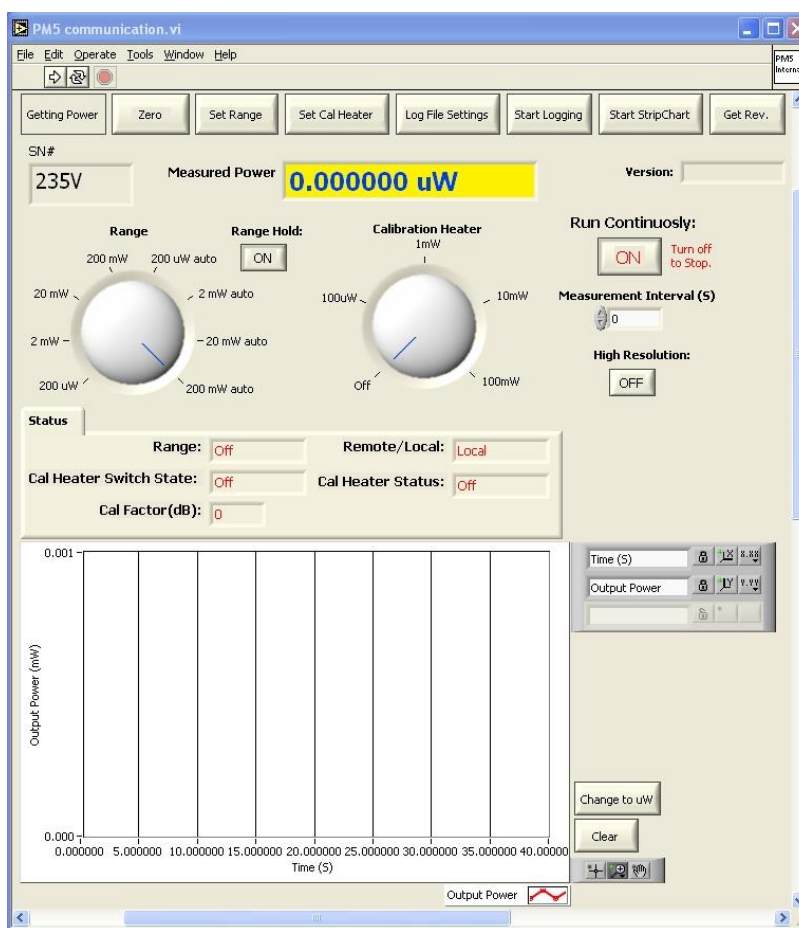

Additional GUI Control Button Information: Pages 12-13

Figure 6:

Screen shot of PM5.exe user interface start-up screen. The graph is a generic Labview 7 graph control with the exception of the “Clear” button, which erases previous data points and the “Change to μ W” button which switches the Y-axis units between milliwatts and microwatts. The full Labview 7.0 version of this program can be found on the flash memory drive.

GUI Control Button Overview

Each button in the top row of the Graphical User Interface (GUI) implements a function when clicked

The screenshot shows the 'PM5 communication.vi' GUI. The top row contains buttons: 'Getting Power', 'Zero', 'Set Range', 'Set Cal Heater', 'Log File Settings', 'Start Logging', 'Start StripChart', and 'Get Rev.'. The main area displays 'Measured Power' as 0.000000 uW, 'SN#' as 235V, and 'Version' as an empty field. There are two rotary knobs for 'Range' and 'Calibration Heater'. A 'Status' section shows 'Range: Off', 'Remote/Local: Local', 'Cal Heater Switch State: Off', and 'Cal Heater Status: Off'. A 'Strip Chart' plot shows 'Output Power (mW)' vs 'Time (S)'. A 'Run Continuously' section has an 'ON' button and 'Turn off to Stop.' text. A 'Measurement Interval (S)' field is set to 0, and 'High Resolution' is 'OFF'. A 'Time (S)' field is set to 0.000000. A 'Change to uW' button and a 'Clear' button are also present.

Get Power
returns the measured power from PM5

Zero
is equivalent to the front panel 'Zero Button'

Set Range
changes range to value selected by 'Range' knob below 'SN#'

Set Cal Heater
sets value selected by 'Calibration Heater' knob

Log File Settings
opens window to name a file for logging power measurements

Start Logging
starts or stops logging data to a selected file

Start Strip Chart
starts or stops plotting to the graph below

Get Rev.
populates the 'Version' field with the PM5 firmware revision number

Run Continuously
starts / stops continuous data collection

Measurement Interval
sets time (Sec) between points in strip chart plot

High Resolution
switches command set; returns more measured data bits

Range Hold
applies / holds setting selected by 'Range' knob

Range
selects power range to be measured

Calibration Heater
reflects values chosen

Status
shows settings of all major meter functions

Strip Chart
displays measured data while it is being collected and logged

GUI Control Button Details

Each button in the top row of the Graphical User Interface (GUI) implements a function when clicked

- “Get Power” returns the measured power from the PM5.
- “Zero” is equivalent to the front panel “Zero Button” on the instrument.
- “Set Range” changes the range to the value selected by the “Range” knob below the serial number field.
- “Range Hold” applies and also holds the range setting selected by the “Range” knob.
- “Set Cal Heater” sets the calibration heater according to the value selected by the “Calibration Heater” knob to the right of the “Range” knob.
- “Log File Settings” opens a window that allows browsing file names/locations in which to place logged readings. It also allows creating an original filename and location for logging power measurements to a text file.
- “Start Logging” starts and stops logging data to a selected file.
- “Start Strip Chart” starts and stops plotting to the graph at the bottom of the program’s window.
- “Get Rev.” returns the revision number of the PM5 firmware and places this number in the “Version” field.

Other GUI Controls and Indicators

- “Measurement Interval” sets the time in seconds between points for plotting to the Strip Chart and logging to a file. The program will attempt to achieve this time, but will not be able to go faster than the sampling rate of the PM5 as described in the specifications.
- “High Resolution” switches the program to a different command set that returns more bits when measuring power. The default command set returns 16 bits for the power measurement over the USB (same rate as PM4). However, the PM5 has up to 10 times less noise. Sixteen bits does not provide enough resolution to realize the full benefits of the noise improvements of the PM5; therefore, the PM5 also responds to a new command for measuring power that returns more bits. The PM5 does not return the status byte while returning a power measurement with higher resolution. When “High Resolution” is “ON” the calibration factor used for the GUI outputs will not be updated until “High Resolution” is turned “OFF.”
- “Status” shows the settings of all meter functions. The settings of the switches determine which functions are enabled.
- “Remote/Local” shows the front panel range switch setting. “Local” refers to any range other than “Remote.” In “Local” the GUI cannot set the range, but will perform the other functions.

Any selection of the back panel calibration heater switch other than “OFF” allows full control of the calibration heater. For example: Even on the 200 μ W setting, the meter can be calibrated on any range.

- “Cal Heater Switch State” shows the position of the rear panel switch.
- “Cal Heater Status” shows the actual calibration setting.

The last row of the GUI shows the setting of the “Cal Factor” front panel switch.

The PM5 power meter has a USB Type B connector jack at the rear that can be used to interface with the instrument. The USB interface uses an FTDI chip (Future Technology Devices International). Commands can be sent and received by a computer as a series of bytes by using FTDI device drivers. The bytes can be sent using the function “FT_Write” in the device driver FTD2XX.dll, and the return bytes can be read with “FT_Read”. The Labview library “PM5.lib” includes the programming diagrams that calls functions in FTD2XX.dll to send and receive data via the USB. Alternately, the USB interface will also be installed as a Virtual COM port to allow communications with software designed to communicate using COM ports. Also included on the memory stick provided by VDI are other Labview VIs that use other functions in FTD2XX.dll not used by the “PM5 Communication.vi” program. See the “FTD2XX programming guide” on the memory stick for more information about controlling communication via the USB.

Communications to the PM5 that are similar to the PM4 must contain eight byte characters. All messages are prefaced with the synchronizing character “!” (0x21) or “?” (0x3f) and terminated with a carriage return (x0d). There is no checksum or other method of validation within the protocol.

The first, second, third and last bytes are ASCII characters. The first, second and third bytes are the command characters as shown in Table 1 below. “Set” commands start with the character “!”. In this instance values are written to the PM5. “Query” commands start with the character “?”. In this instance the PM5 writes values to the computer. Bytes 4 through 7 are binary. Of the binary bytes, Byte 4 is the LSB and Byte 7 is the MSB. Bytes 4 through 7 are ignored by most of the commands, except Byte 4 represents rangehold (1-hold, 0-autorange) for the auto scales.

For Communication to the PM5

Table 1: Command Set for PM5 USB Communications

Byte 1	Byte 2	Byte 3	Command
			Set Commands
!	'null'	'null'	No action
!	S	Z	Set Zero (same as pushing zero button)
!	S	C	Calibrate
!	R	1	Set FP Range 200 μ W
!	R	2	Set FP Range 2 mW
!	R	3	Set FP Range 20 mW
!	R	4	Set FP Range 200 mW
!	R	5	Set FP Range 200 μ W auto
!	R	6	Set FP Range 2 mW auto
!	R	7	Set FP Range 20 mW auto
!	R	8	Set FP Range 200 mW auto
!	C	0	Calibration Heater OFF
!	C	1	Calibration Heater 100 μ W
!	C	2	Calibration Heater 1 mW
!	C	3	Calibration Heater 10 mW
!	C	4	Calibration Heater 100 mW
			Query Commands
?	'null'	'null'	No action
?	V	C	Query firmware code
?	D	1	Transmit Request one sample
?	D	S	Transmit Stream samples

Communication Protocol / Communication from the PM5

PM5 Communication Protocol

On receipt of a message, the PM5 will acknowledge with an ACK (0x06) if the message was received and parsed correctly or a NAK (0x15) if it was not. "Parsed correctly" is defined as receiving eight bytes, starting with the synchronizing character "!" (0x21) or "?" (0x3f) and terminating with a carriage return (x0d). The action requested by the command is begun upon the correct parsing of the command.

Because this action may take many milliseconds to complete, the ACK only indicates the correct parsing, not the completion of the action. It is assumed that the action will complete successfully. The protocol does not provide detailed fault information.

The PM5 assumes the host is always capable of receiving messages and will only transmit a single message in response to a command. The host must be capable of accepting unsolicited messages back-to-back in rapid succession; this situation will occur if streaming power output data is requested. The host must not respond with an ACK nor a NAK upon receipt of power output data.

For Communication from the PM5

The response from the PM5 has a six byte message format. Byte 1 is an ASCII character. Byte 2 can be an ASCII character or straight binary depending on Byte 1. Bytes 4 through 6 are straight binary. The response returned from the query 'D1' or 'DS' has the following format:

Byte 1 is 'D'.
Byte 2 is the LSB of the data.
Byte 3 is the MSB of the data.
Byte 4 is Status Byte 1.
Byte 5 is Status Byte 2.
Byte 6 is Status Byte 3.

No response from the host is expected after receipt of this message. In the returned response, Bytes 2 and 3 together constitute the data in 16 bit integer format (short integer). These two bytes should be unpacked as a 16-bit integer. In addition, these are 16-bit 2's complement numbers, which will need to be converted from 16 bit 2's complement to decimal.

At this point, after converting to decimal, we have a number that is the raw count value (let us call this number countvalue). The actual reading is then computed from the countvalue, and based on what the range value is, and if there is a cal factor set in the front panel. The formula to get the reading from the countvalue and range value (defined here as variable rangeval):

$$\text{reading} = \text{countvalue} * 2.^{\text{rangemax}(\text{rangeval})} / 59576.$$

where rangemax = 200.E-6 for rangeval=1, or 2.E-3 for rangeval=2, or 20.E-3 for rangeval=3, or 200.E-3 for rangeval=4. The range value setting is also available in the status bytes (see below). If there is a cal factor on the front panel, the reading from the formula above should be further modified as:

$$\text{reading} = \text{reading} * 10^{(\text{calfactor}/10.)}$$

where calfactor is the decimal calfactor that you can read from the front of the panel.

This cal factor is also present in Status Byte 3 – See all three Status Byte definition tables on the next page.

Status Bytes 1, 2 and 3 Definition Tables

Status Byte 1 Definition:

bit 7	Auto Range	
	1	In auto range
	0	Not in auto range
bit 6:4	Cal Heater	
	000	OFF
	001	100 μ W
	010	1 mW
	011	10 mW
	100	100 mW
bit 3:1	Rear Cal Switch	
	000	OFF
	001	100 μ W
	010	1 mW
	011	10 mW
	100	100 mW
bit 0	Local/Remote	
	1	Remote
	0	Local

Status Byte 2 Definition:

bit 7:4	Cal Factor	ones digit, binary encoded
bit 3:0	Cal Factor	decimal point digit, binary encoded

Status Byte 3 Definition:

bit 7:5 Range Status Bits	Range Selected	Auto determined by Byte1 bit7
	000	OFF, no range selected
	001	200 μ W
	010	2 mW
	011	20 mW
	100	200 mW
	111	Error, multiple ranges selected
bit 4	Cal Factor	Sign digit, 1 is "-", 0 is "+"
bit 3:0	Cal Factor	tens digit, binary encoded

Response Return Format and Command Descriptions

The response returned from the query “VC” has the following format:

Byte 1 is “V”
Byte 2 is “C”
Byte 3 is the decimal portion of the firmware code revision
Byte 4 is the integer portion of the firmware code revision
Byte 5 is the decimal portion of the secondary firmware code revision
Byte 6 is the integer portion of the secondary firmware code revision

Example: In firmware code Rev. 1.2 and secondary firmware code Rev. 3.5, the following string would be received: VC2153. No response from the host is expected after receipt of this message.

Detailed Command Description

Set Commands

SZ – will set the zero for the current range. This is the same as pressing the front panel Zero Button. Bytes 4-7 must be sent but the receiver ignores. The value will be stored in the serial EEPROM.

SC – will set the calibration for the current range. It is presumed that when this command is sent the calibration heater is set at exactly half scale for the range, and has had enough time to settle. Bytes 4-7 must be sent but the receiver ignores. The value will be stored in the serial EEPROM.

R1 – if the front panel rotary switch is set to “Remote,” this will change the range to 200 μ W. Bytes 4-7 must be sent but the receiver ignores.

R2 – if the front panel rotary switch is set to “Remote,” this will change the range to 2 mW. Bytes 4-7 must be sent but the receiver ignores.

R3 – if the front panel rotary switch is set to “Remote,” this will change the range to 20 mW. Bytes 4-7 must be sent but the receiver ignores.

R4 – if the front panel rotary switch is set to “Remote,” this will change the range to 200mW. Bytes 4-7 must be sent but the receiver ignores.

R5 – if the front panel rotary switch is set to “Remote,” this will change the range to 200 μ W auto. Byte 4 turns on Range Hold with a value of 1 and turns off range hold with a value of 0. Bytes 5-7 must be sent but the receiver ignores.

R6 – if the front panel rotary switch is set to “Remote,” this will change the range to 2 mW auto. Byte 4 turns on Range Hold with a value of 1 and turns off range hold with a value of 0. Bytes 5-7 must be sent but the receiver ignores.

R7 – if the front panel rotary switch is set to “Remote,” this will change the range to ‘20mW auto.’ Byte 4 turns on Range Hold with a value of 1 and turns off range hold with a value of 0. Bytes 5-7 must be sent but the receiver ignores.

R8 – if the front panel rotary switch is set to “Remote,” this will change the range to ‘200mW auto.’ Byte 4 turns on Range Hold with a value of 1 and turns off range hold with a value of 0. Bytes 5-7 must be sent but the receiver ignores.

C0 – will set the calibration heater to “OFF” if the back panel Internal Calibration Switch is not set to “OFF.” Bytes 4-7 must be sent but the receiver ignores.

Set, Query and Get Power Commands

Set Commands: Continued

C1 – will set the calibration heater to the preset value of 100 μ W if the back panel Internal Calibration Switch is not set to “OFF.” Bytes 4-7 must be sent but the receiver ignores.

C2 – will set the calibration heater to the preset value of 1 mW if the back panel Internal Calibration Switch is not set to “OFF.” Bytes 4-7 must be sent but the receiver ignores.

C3 – will set the calibration heater to the preset value of 10 mW if the back panel Internal Calibration Switch is not set to “OFF.” Bytes 4-7 must be sent but the receiver ignores.

C4 – will set the calibration heater to the preset value of 100 mW if the back panel Internal Calibration Switch is not set to “OFF.” Bytes 4-7 must be sent but the receiver ignores.

Query commands

D1 – will request one power output sample. Bytes 4-7 must be sent but the receiver ignores. No response will be sent until new data is available, up to 1 sec on the 200 μ W range.

DS – will request streaming of power output samples, (data sent at the internal sample rate). Bytes 4 through 7 must be sent but the receiver ignores. Streaming will continue until the PM5 gets a ‘D1’ command or until the power is turned off. The internal sample rate is 1 Hz on 200 μ W range, 5 Hz on 2 mW range, 20 Hz on 20 mW range and 35 Hz on 200 mW range.

VC – will request the firmware code and secondary firmware code revision data. Bytes 4 through 7 must be sent but the receiver ignores.

High Resolution Get Power Command

The PM4 command structure returns 16 bits representing measured power, which sometimes is not enough for the PM5. An alternate command is available for the PM5 that has greater resolution.

Sending the following series of bytes will prompt the PM5 to return the measurement result over the USB with higher resolution:

[38, 1, 2, 37](#)

After receiving these bytes the PM5 will measure and return 14 bytes. The first returned byte is an error byte. If there was a communication error this byte will be 0xAB, otherwise it will be 0x55. The remaining 13 bytes will be an ASCII text string in exponential notation representing power in milliwatts.

The PM5 determines if there was a communication error by calculating the “Exclusive OR” result of the first three bytes in the command string and compares to the last byte sent. The last byte (37) in the command string is the “Exclusive OR” combination of the previous three bytes and must match the “Exclusive OR” result calculated by the PM5.

To correct for the loss of the WR10 1-inch section and a waveguide taper, the WR10 1-inch section and various tapers were measured using calibrated VNA frequency extension modules for multiple frequency bands, from 90 GHz to 1.1 THz. Contact VDI for information on power measurements above 1.1 THz.

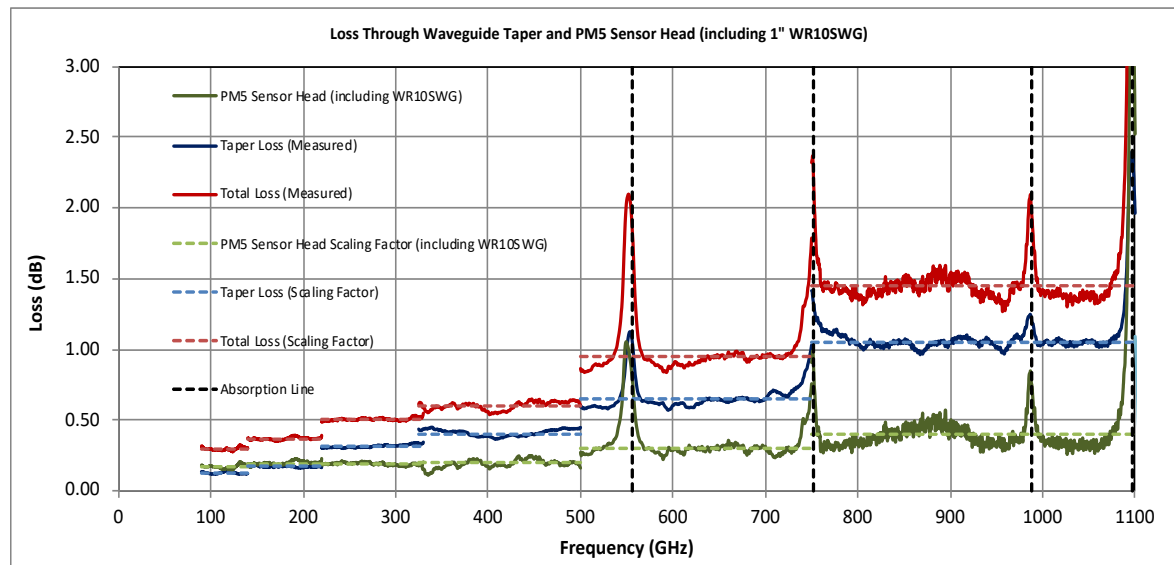

Figure 7:

Data for taper and PM5 sensor head loss for various frequency bands are shown. The loss through the PM5 Sensor Head includes loss through the 1" WR10SWG and internal waveguide losses. Internal waveguide loss is approximated to be the same as the loss through the 1" WR10SWG.

Based on the measurements, the scaling factor for a given waveguide taper can be approximated to a constant value. The dotted black lines indicate significant absorption regions through air (assuming 50% humidity).

Waveguide Band	Loss of PM5 Sensor Head including 1" WR10SWG (dB)	Loss of Waveguide Taper (dB)
WR10	0.17	N/A
WR8.0	0.17	0.13
WR6.5	0.18	0.16
WR5.1	0.19	0.18
WR4.3	0.19	0.28
WR3.4	0.19	0.32
WR2.8	0.20	0.35
WR2.2	0.20	0.40
WR1.9	0.25	0.50
WR1.5	0.30	0.65
WR1.2	0.35	0.85
WR1.0	0.40	1.05
WR0.65	0.60	1.50
WR0.51	0.70	N/A

Figure 8:

This table lists VDI correction factors for various waveguide bands.

Current and Future Measurement Standards

There are no generally accepted standards for power measurements around 100 GHz and above. The purpose of "Appendix Two" is to describe the methods that VDI uses to measure power levels from VDI sources. In this way VDI hopes to keep its customers fully informed of its measurement techniques and foster a greater discussion of the best methods to perform such measurements. Possible methods to compare power measurements made by different research laboratories are also important topics, but they have not been considered here. VDI will update this document from time to time to reflect improved measurement techniques and equipment upgrades.

Sensor Head



The PM5's Sensor Head weighs approximately 8 ounces (about .22 kg). Despite its robust construction it should not be dropped or roughly handled since its internal components, connection points, and the Flange can be misaligned or damaged.

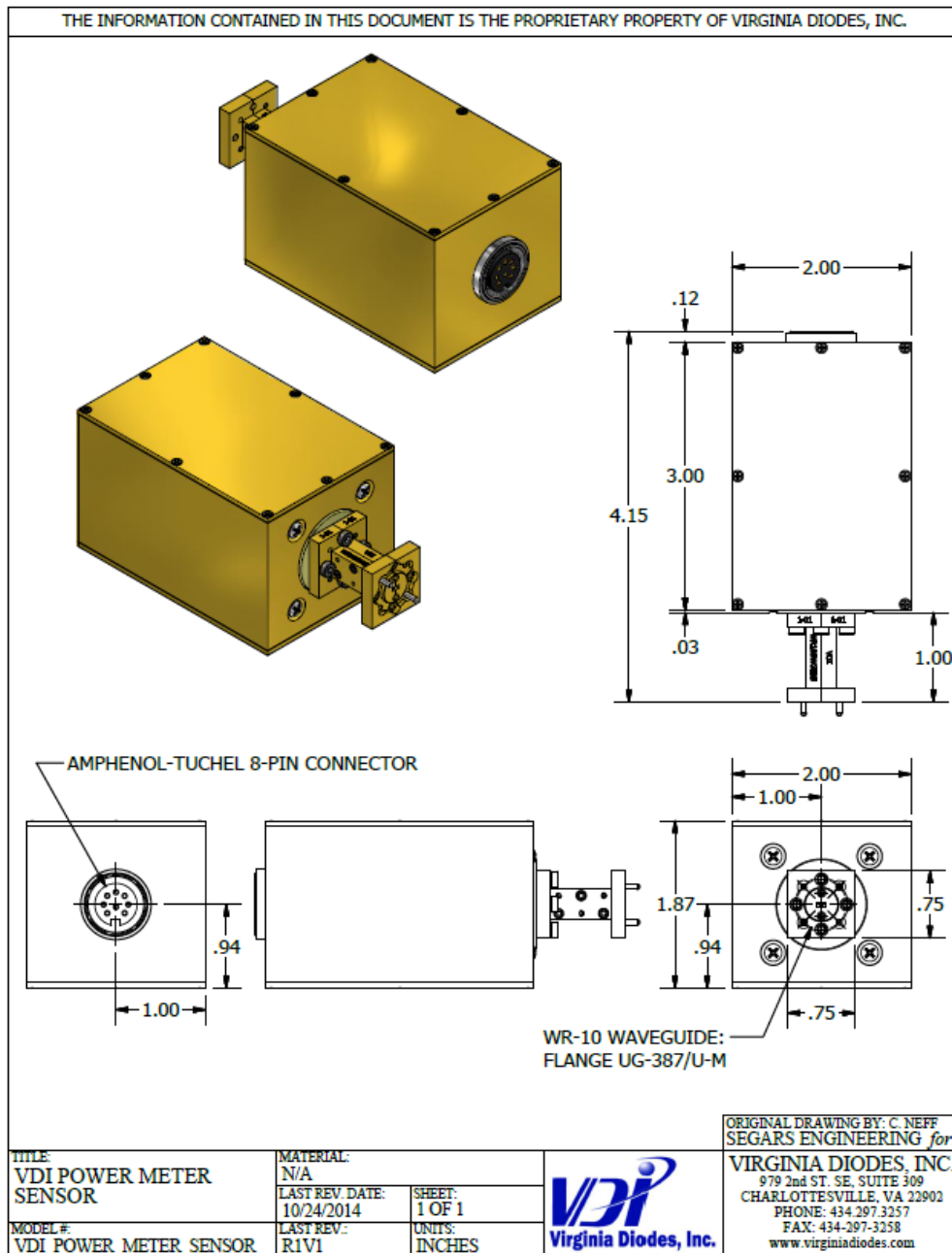

PM5 Mechanical Drawing: WR10 1-Inch Taper

WR10 1-Inch, Self-Symmetric Taper

THE INFORMATION CONTAINED IN THIS DOCUMENT IS THE PROPRIETARY PROPERTY OF VIRGINIA DIODES, INC.

WAVEGUIDE FLANGES:
(2) WR-x.x/WM-xxx, UG-387/U-M

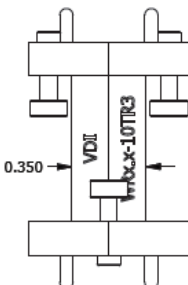
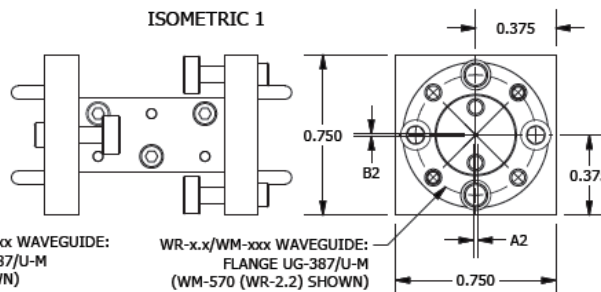
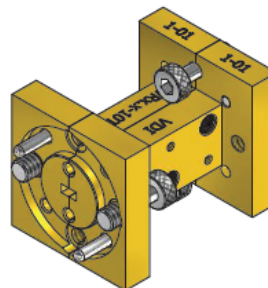
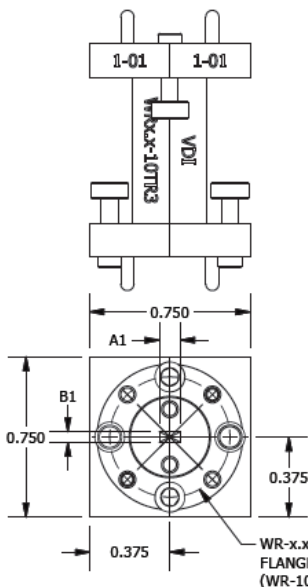
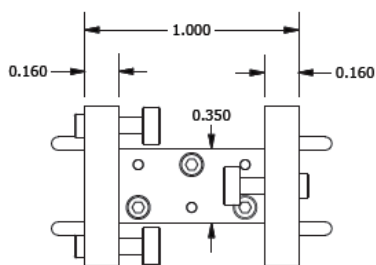

BASIC DIMENSIONS		
WAVEGUIDE	A1, A2	B1, B2
WR-15	3759 micron	1880 micron
WR-12	3099 micron	1549 micron
WR-10	2540 micron	1270 micron
WR-8.0	2032 micron	1016 micron
WR-6.5	1651 micron	825.5 micron
WR-5.1	1295 micron	647.5 micron
WR-4.3	1092 micron	546 micron
WR-3.4	864 micron	432 micron
WM-710 (WR-2.8)	710 micron	355 micron
WM-570 (WR-2.2)	570 micron	285 micron
WM-470 (WR1.9)	470 micron	235 micron
WM-380 (WR1.5)	380 micron	190 micron
WM-310 (WR-1.2)	310 micron	155 micron
WM-250 (WR-1.0)	250 micron	125 micron
WM-200 (WR-0.8)	200 micron	100 micron
WM-164 (WR-0.65)	164 micron	82 micron

NOTE: SPECIFICATIONS AND CHARACTERISTICS ARE TYPICAL AND SUBJECT TO CHANGE AT ANY TIME.

TITLE:
1" SELF-SYMMETRIC TAPER

MODEL #:
WRx.x-10TR3

MATERIAL:
ALUMINUM ALLOY 6061-T6

REV. DATE:
04/22/2014

REV.:
R3V1

SHEET:
1 OF 1

UNITS:
INCH



ORIGINAL DRAWING BY: R. WENGER
SEGARS ENGINEERING for:

VIRGINIA DIODES, INC.
979 2nd ST. SE, SUITE 309
CHARLOTTEVILLE, VA 22902
PHONE: 434.297.3257
FAX: 434.297.3258
www.virginiadiodes.com

Addendum — Product Updates and Company Contacts

Virginia Diodes' PM5 is an industry-leading solution for high frequency power measurement. Each generation of our Erickson calorimetric power meter incorporates advances in accuracy, speed, convenience and other benefits. Thanks to widespread industry acceptance, the PM5 has become a *defacto* standard for power measurement above 100 GHz.

The Virginia Diodes' staff of engineering and physical science professionals works to continually improve our products. We also depend upon feedback from colleagues and customers. Ideas to simplify the meter's operations, improve performance or add capabilities are always welcome. Be certain that Virginia Diodes has your latest contact details including a phone number and an email address to receive update advisories.



Contact VDI:

Virginia Diodes, Inc.

Web: <http://www.vadiodes.com>

Email: Technical@vadiodes.com

Telephone: 434.297.3257