



Waveguide Quick Connect, 0.75" Circular Flange

Description:

Model SWH-QC-0750C-R2 is a waveguide quick connect apparatus, which is designed and manufactured primarily for quick connect and disconnect operations, for 0.75" circular flanges. The quick connect allows for the fast mating and clamping of two flanges with an easy turning of the hand screws. It is designed to be used for UG-385/U, UG-387/U, and UG-387/U-M flanges and is intended for lab or sub-assembly use where frequent connects and disconnects are encountered. In addition, it is also designed for sub-assemblies and lab setup where the waveguide flange connections are in a tight space and not enough room is presented for standard waveguide screw connections. Furthermore, the quick connect provides even pressure on the flanges in order to create a perfect connection that reduces signal leakage due to waveguide misalignment.



The model for 1.125" circular flanges, such as UG381/U and UG383/U and UG383/U-M is offered under model number SWH-QC-1125C-R2.

In addition, a matched post stand is also offered under model number of SWH-QC-0750C-RS-B for bench top and/or tripod mount applications.

Features:

- Hand Screw Clamping
- Fast Connection and Disconnection
- Tight Space Waveguide Flange Connection and Disconnection
- Waveguide Support when used with Stand
- Leaking Prevention

Applications:

- Test Instrumentation
- Sub-assemblies
- Lab Use

Mechanical Specifications:

Item	Specification
Compatible Flange Type I	UG-385/U
Compatible Flange Type II	UG-387/U
Compatible Flange Type III	UG-387/U-M
Dimensions	1.50" x 1.25" x 0.44"
Material	Brass and Stainless Steel
Weight	1.3 Oz
Outline	WH-0750C-R-BX1





Waveguide Quick Connect, 0.75" Circular Flange

Mechanical Outline: (Unless otherwise specified, all dimensions are in inches [millimeters])

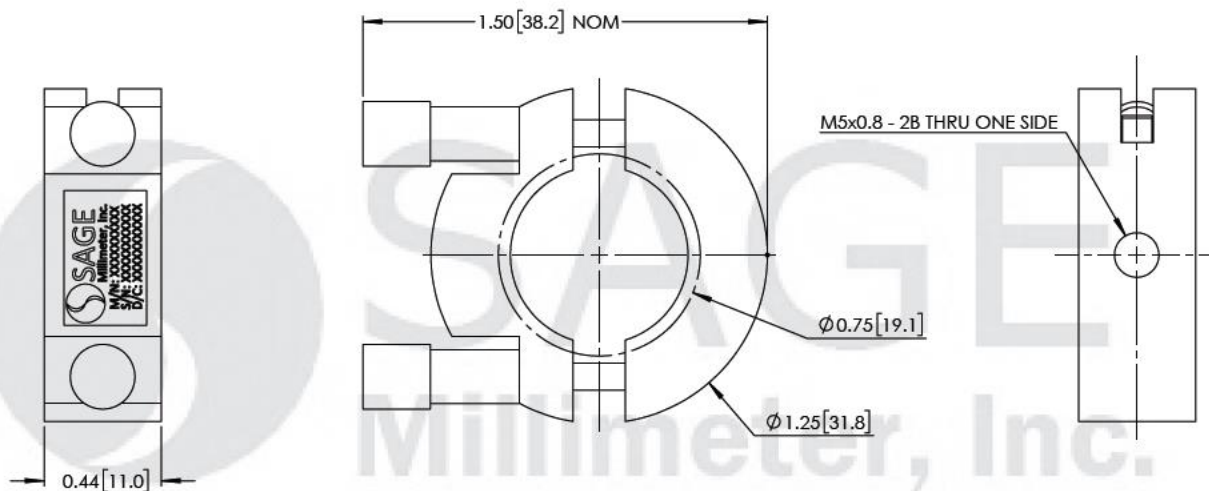

Closed and Open View:

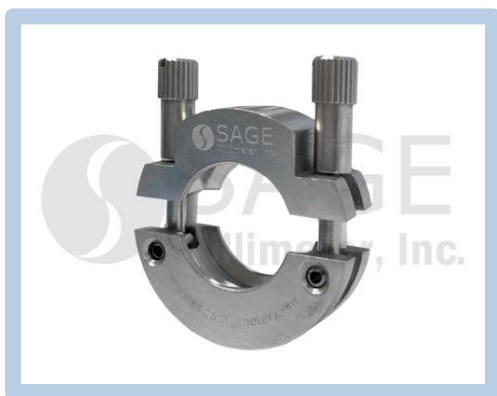

Note:

- SAGE Millimeter, Inc. reserves the right to change the information presented without notice.

