

SCA-15-KMKF-SD

2.92 mm Coaxial Fixed Attenuator, 15 dB Attenuation

SCA-15-KMKF-SD is a 15 dB coaxial attenuator that is used in millimeterwave systems and operates from DC to 40 GHz. The attenuator has a typical attenuation value of 15 dB across the frequency range. While the attenuator is designed and fabricated for full 2.92 mm coaxial band applications, the attenuation value of this model will have a wide range due to its broadband coverage. Various attenuation values are available under different model numbers.



Electrical Specifications:

Parameter	Minimum	Typical	Maximum
Frequency Range	DC		40 GHz
Attenuation		15 dB	
Attenuation Accuracy		±0.6 dB	
Return Loss		19 dB	
Power Handling			2 W (CW)
Impedance		50 Ω	
Specification Temperature		+25 °C	
Operating Temperature	-40 °C		+85 °C

Mechanical Specifications:

Item	Specification
Connector 1 Type	2.92 mm (K) Male
Connector 2 Type	2.92 mm (K) Female
Body Material	Stainless Steel
Body Finish	Passivated
Connector Pin Material	Beryllium Copper
Connector Pin Finish	Gold Plated
Insulator Material	PEI
Weight	0.3 Oz
Length	0.68"
Outline	CA-K-9

ECCN

EAR99

FEATURES

- Broadband Coverage
- Low Cost

APPLICATIONS

- Test Lab
- Instrumentations
- System Integration

SUPPLEMENTAL DETAILS



SCA-15-KMKF-SD

Typical Performance vs. Frequency

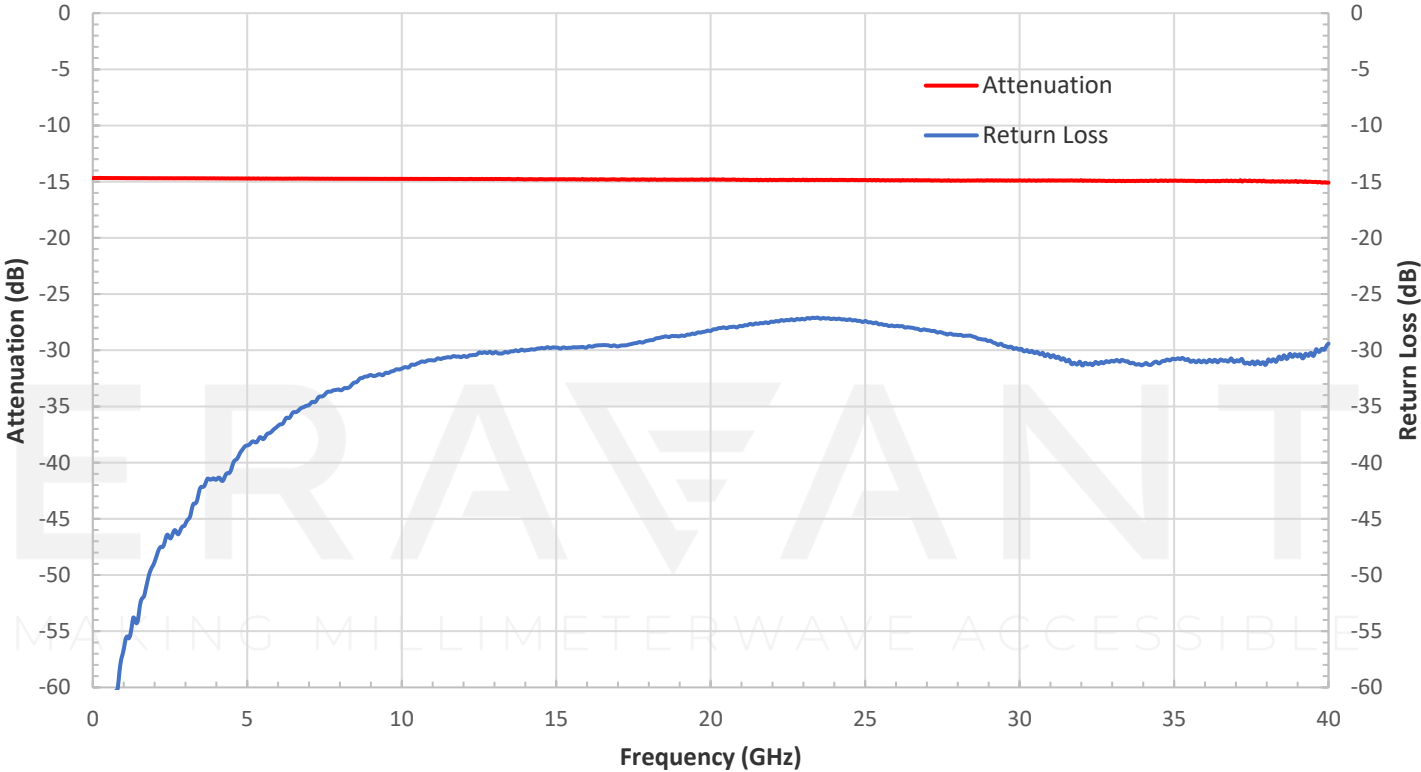

Mechanical Outline: (Unless otherwise specified, all dimensions are in inches [millimeters])

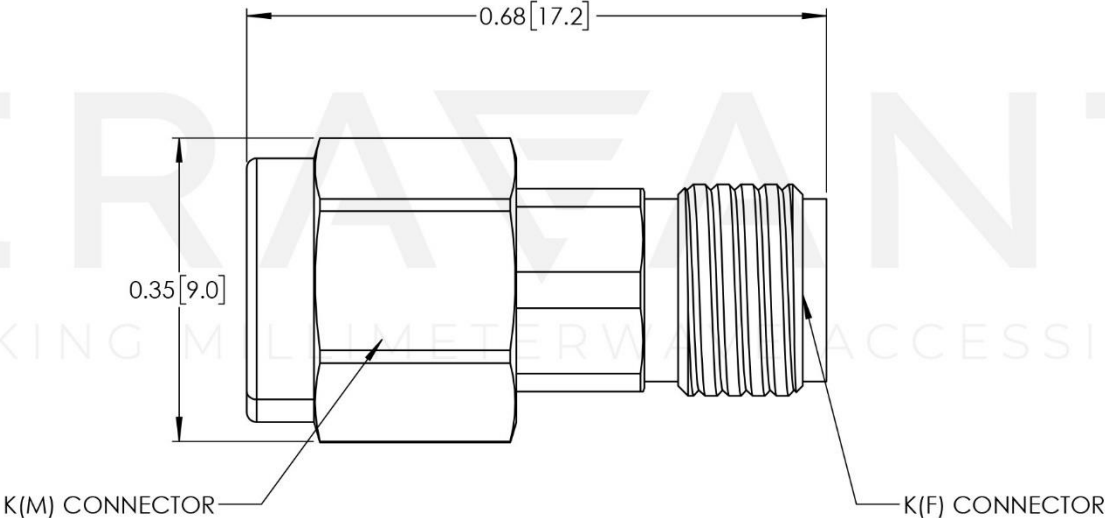

SCA-15-KMKF-SD

NOTE:

- All data presented is collected from a sample lot. Actual data may vary slightly from unit to unit.
- All testing is performed under +25 °C case temperature.
- Eravant reserves the right to change the information presented without notice.

CAUTION:

- Exceeding absolute maximum ratings shown will damage the device.
- Proper torque should be applied: 8.0 ± 0.15 inch-pounds (0.90 ± 0.02 Nm). Torque wrench model SCH-08008-S1 is highly recommended.

ERAVANT

MAKING MILLIMETERWAVE ACCESSIBLE

ERAVANT

MAKING MILLIMETERWAVE ACCESSIBLE