

## SAT-943-09410-C1

### W-Band Orthomode Transducer, Narrow Band

**SAT-943-09410-C1** is a WR-10 orthomode transducer (OMT) that operates between 92 and 96 GHz. It separates a circular or elliptical polarized waveform into two linear, orthogonal waveforms or combines two linear polarized waveforms into one circular or elliptical polarized waveform or vice versa. The OMT also supports either vertical or horizontal polarized waveguide forms. The OMT shows high port isolation while providing a low insertion loss. The OMT is configured with a 0.094" diameter circular waveguide for the antenna port and two WR-10 waveguides for the horizontal and vertical ports. All ports have standard UG-387/U-M anti-cocking flanges and 4-40 threaded holes.



#### Electrical Specifications:

Parameter	Minimum	Typical	Maximum
Frequency Range	91.5 GHz	94 GHz	96.5 GHz
Insertion Loss (H to A Port)		1.2 dB	
Insertion Loss (V to A Port)		1.0 dB	
Isolation (H to V Port)		35 dB	
Return Loss (H Port)		17 dB	
Return Loss (V Port)		17 dB	
Return Loss (A Port, Vertical)		17 dB	
Return Loss (V Port, Horizontal)		17 dB	
Specification Temperature		+25°C	
Operating Temperature	-40°C		+85°C

#### Mechanical Specifications:

Item	Specification
Antenna Port	Ø 0.094" Circular Waveguide
Horizontal and Vertical Ports	WR-10 Waveguide
Flange Type	UG-387/U-M Anti-Cocking Flange with 4-40 Threaded Holes
Material	Aluminum
Finish	Gold Plated
Weight	1.5 Oz
Outline	AT-WC-094-N-A

#### ECCN

EAR99

#### FEATURES

- Compact Size
- High Port Isolation
- Low Insertion Loss

#### APPLICATIONS

- Radar Systems
- Communication Systems
- Antenna Ranges
- Circular and Linear Waveform Separation and Combination

#### SUPPLEMENTAL DETAILS



## SAT-943-09410-C1

### Typical Performance vs. Frequency

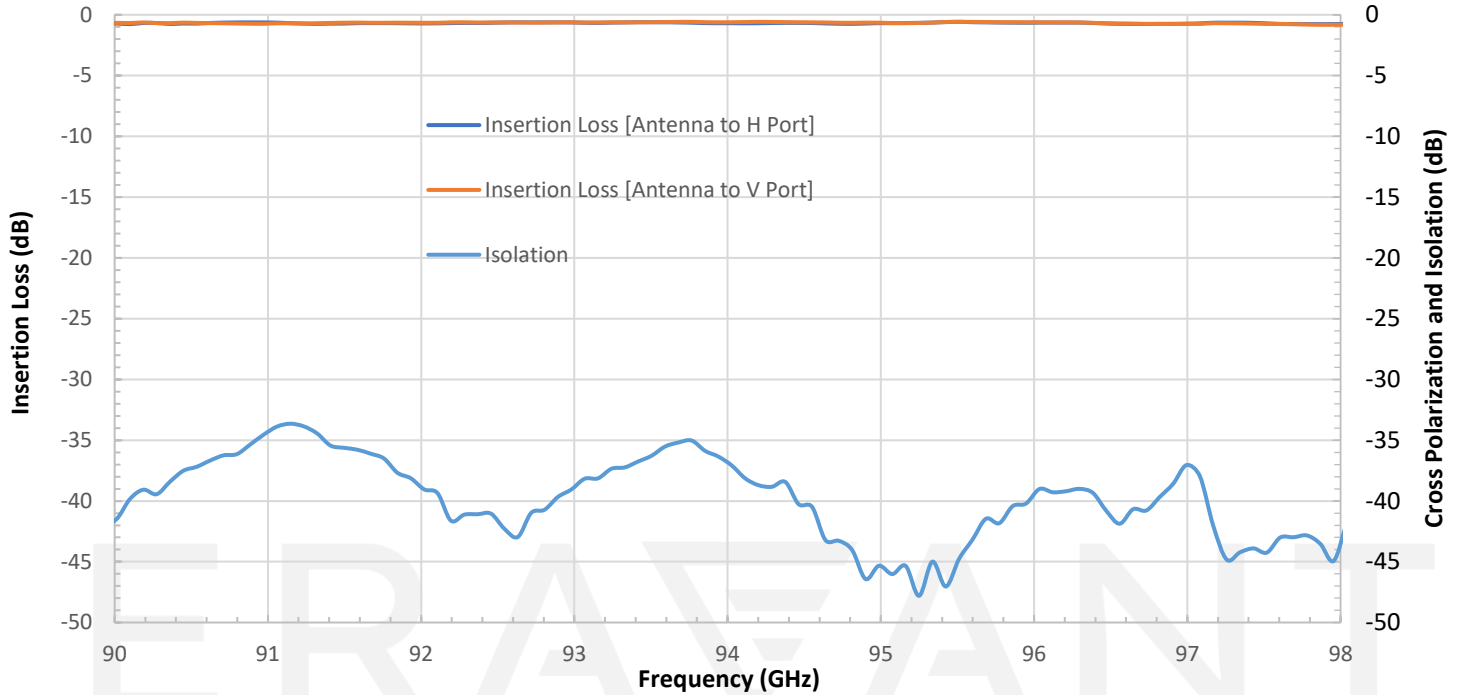

**Mechanical Outline:** (Unless otherwise specified, all dimensions are in inches [millimeters])

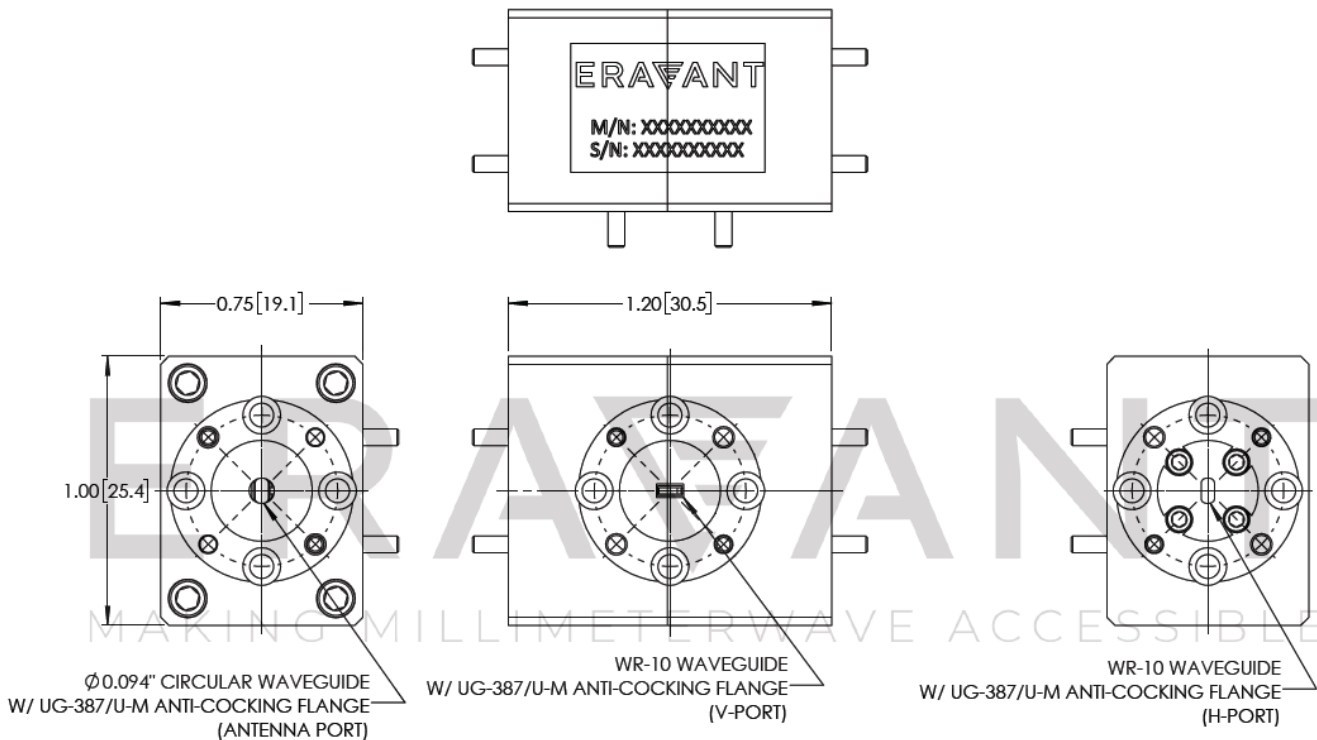

**NOTE:**

- All data provided is collected from a sample lot. Actual data may vary slightly from unit to unit. All testing is performed under +25 °C room temperature.
- Eravant reserves the right to change the information presented without notice.

**CAUTION:**

- Any foreign objects in the waveguide will cause performance degradation and may damage or destroy the unit.
- For 1 mm connectors proper torque should be applied:  $4.0 \pm 0.15$  inch-pounds ( $0.45 \pm 0.02$  Nm). Torque wrench model SCH-06004-S1 is highly recommended.
- For 1.35 mm, 1.85 mm, 2.4 mm, 2.92 mm, and SMA connectors proper torque should be applied:  $8.0 \pm 0.15$  inch-pounds ( $0.90 \pm 0.02$  Nm). Torque wrench model SCH-08008-S1 is highly recommended.

ERAVANT  
MAKING MILLIMETERWAVE ACCESSIBLE

ERAVANT  
MAKING MILLIMETERWAVE ACCESSIBLE