

SAS-453-21922-F1

Q/V Band Linear to Circular Polarizer, 37.5-52.4 GHz

SAS-453-21922-F1 is a Q/V band, linear to circular polarizer that operates from 37.5 GHz to 52.4 GHz. The polarizer offers a typical insertion loss of 0.1 dB, typical axial ratio of 0.5 dB, and a typical return loss of 25 dB. The polarizer is fixed and can be used for either right-handed or left-handed polarization based on the direction of the input signal.



Electrical Specifications:

Parameter	Minimum	Typical	Maximum
Frequency Range	37.5 GHz		52.4 GHz
Insertion Loss		0.1 dB	
Axial Ratio		0.5 dB	
Return Loss		25 dB	
Specification Temperature		+25°C	
Operating Temperature	-40°C		-85°C

Mechanical Specifications:

Item	Specification
RF Ports	Ø0.219" Circular Waveguide with UG-383/U-M Anti-Cocking Flange
Material	Aluminum
Finish	Chem Film
Weight	0.6 Oz
Outline	AS-FQN-219-A

ECCN

EAR99

FEATURES

- Compact Size
- Low Insertion Loss
- Low Axial Ratio
- Full Q/V-Band Coverage

APPLICATIONS

- Q/V-Band SATCOM Systems

Measured Insertion Loss and Return Loss vs Frequency

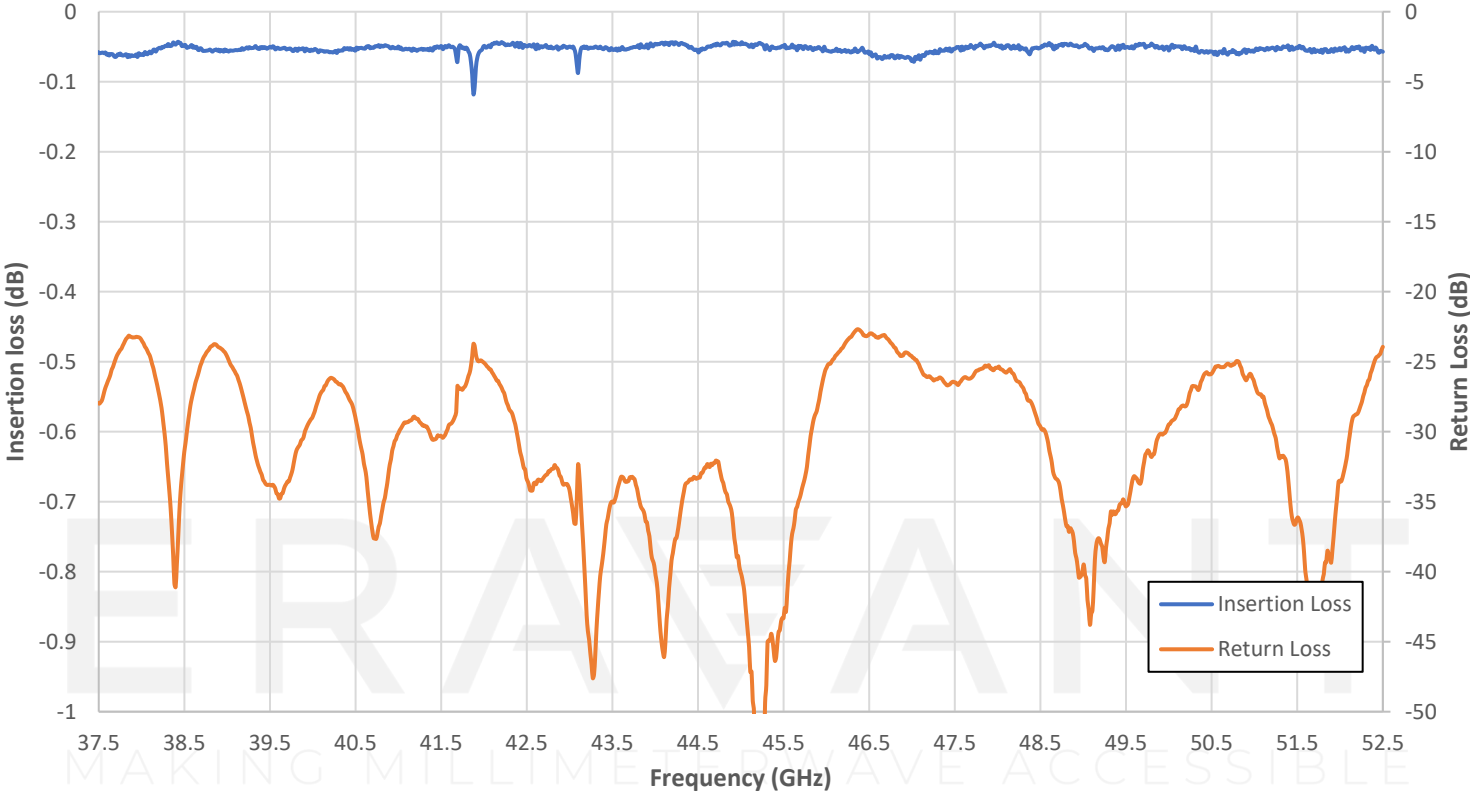

Measured Axial ratio vs frequency

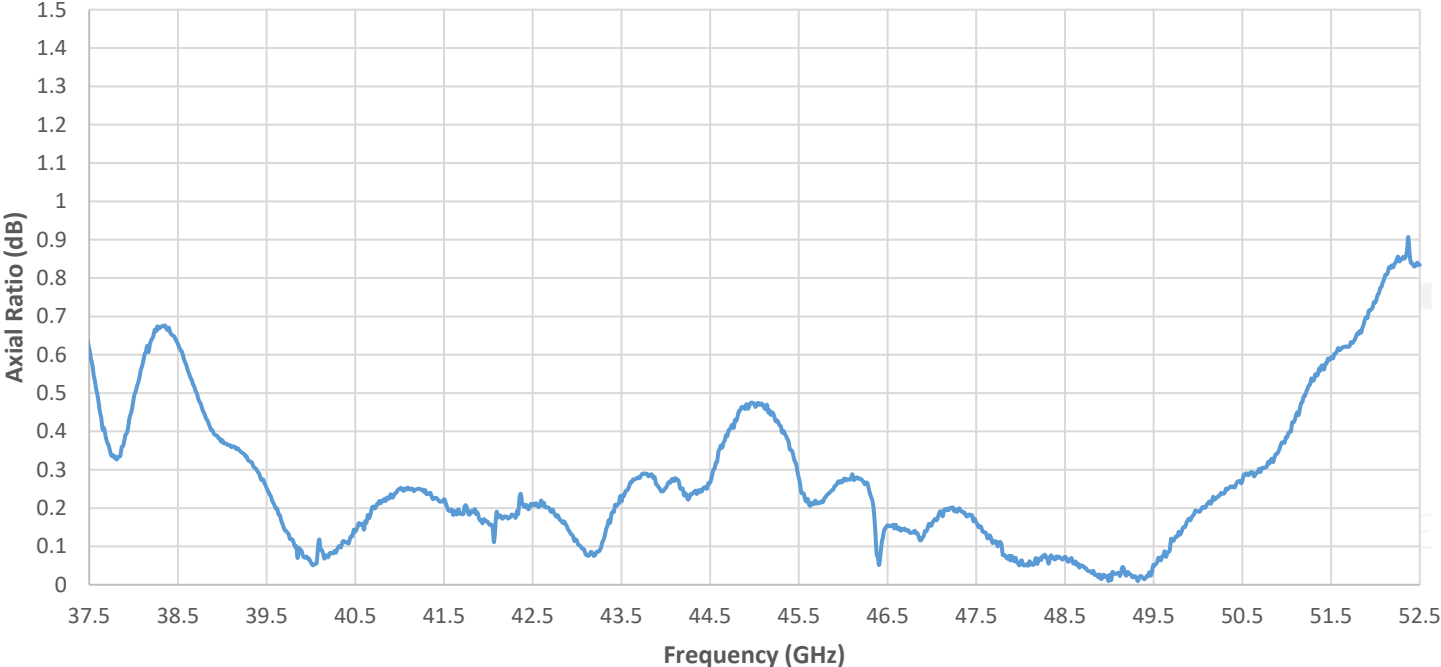

SAS-453-21922-F1

Mechanical Outline:

Unless otherwise specified, all dimensions are in inches [millimeters]

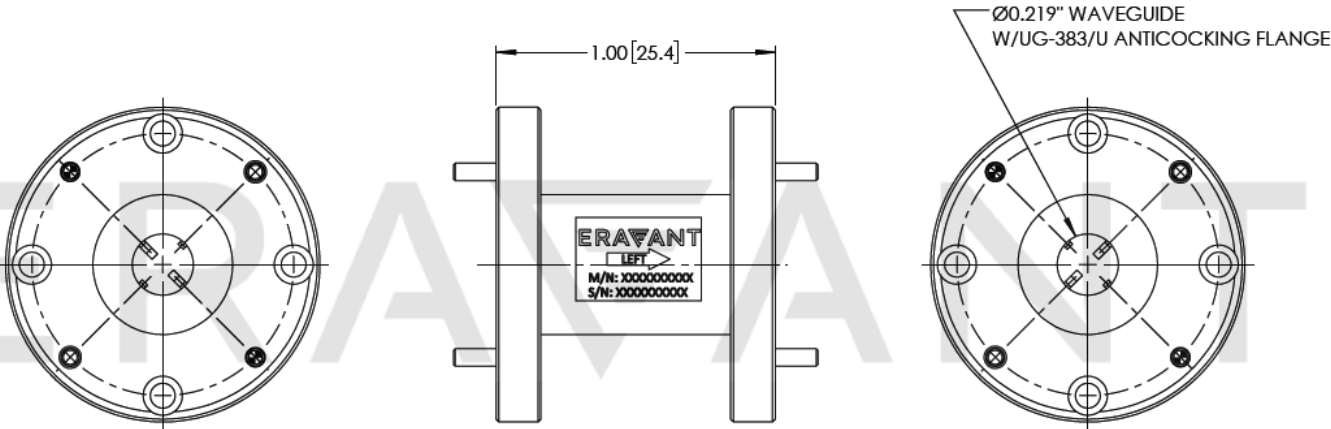

NOTE:

- Test data is collected from a sample lot. Actual data may vary slightly from unit to unit. All testing is performed under +25 °C room temperature.
- Eravant reserves the right to change the information presented without notice.

CAUTION:

- Any foreign objects in the antenna will cause performance degradation and possible device damage.

LHCP and RHCP Polarization Configuration Notes and Diagram:

- The polarizer's product label indicates the direction of **Left-Handed Circular Polarization (LHCP)**.
- An example configuration diagram is provided below. The diagram indicates the input and output ports and the orientation in which the polarizer is to be attached to the rest of the components to obtain an LHCP signal at the output port.
- The polarizer can be configured to obtain a **Right-Handed Circular Polarized (RHCP)** signal at the output port by reversing the input and output ports as shown in the second diagram.

