

## SAO-2734030810-28-S1

### Full Ka-Band Omnidirectional Antenna, 10°, 7.5 dBi Gain

**SAO-2734030810-28-S1** is a full band, WR-28 omnidirectional antenna that operates between 26.5 and 40 GHz. This vertically polarized antenna offers 360 degrees azimuth coverage with a 7.5 dBi typical gain and  $\pm 1$  dB nominal gain flatness. The antenna features a half power beamwidth of 10 degrees in the vertical direction. The RF port of the antenna is equipped with WR-28 waveguide with UG-599/U flange. The version with 2.92 mm (F) interface is offered under model number, SAO-2734030345-KF-S1.



#### Electrical Specifications:

Parameter	Minimum	Typical	Maximum
Frequency Range	26.5 GHz		40 GHz
Gain		7.5 dBi	
Azimuth Gain Variation		$\pm 1$ dB	
Azimuth Beamwidth		360°	
3 dB Vertical Beamwidth		10°	
Return Loss		9 dB	
Power Handling		150 W	200 W
Specification Temperature		+25°C	
Operating Temperature	-40°C		+85°C

#### Mechanical Specifications:

Item	Specification
Input	WR-28 Waveguide with UG-599/U Flange
Body Material	Aluminum
Radome Material	HDPE
Finish	Clear Chem Film
Weight	2.2 lbs
Size	3.39" (H) x 5.70" (Ø)
Outline	AO-A08-010

#### ECCN

EAR99

#### FEATURES

- 360° Azimuth Coverage
- 10° Vertical 3 dB Beamwidth
- Vertically Polarized
- Full Band Operation

#### APPLICATIONS

- 5G System
- Communication Links
- EW Systems
- Indoor Local Area Network

#### SUPPLEMENTAL DETAILS

## SAO-2734030810-28-S1

### Typical E-Plane Antenna Pattern @ 26.5 GHz

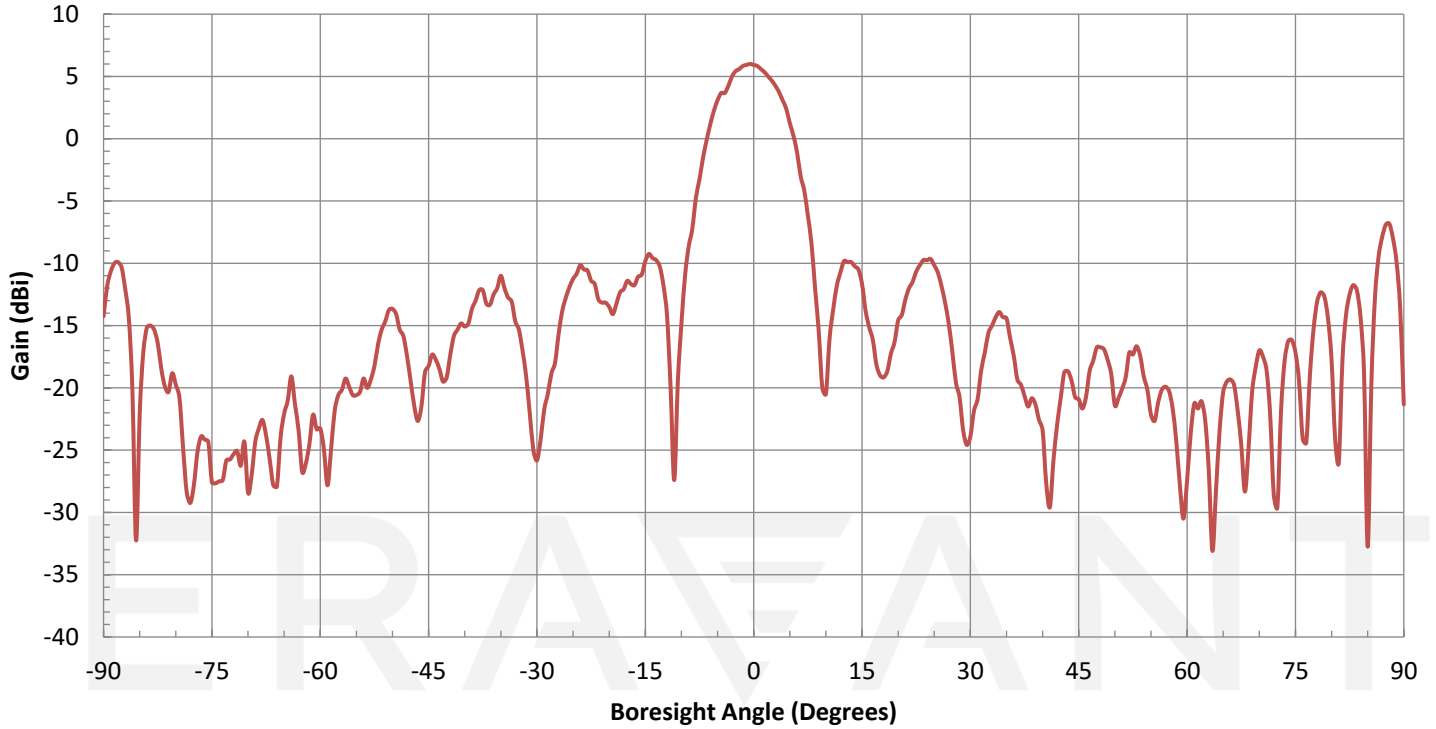

### Typical E-Plane Antenna Pattern @ 33 GHz

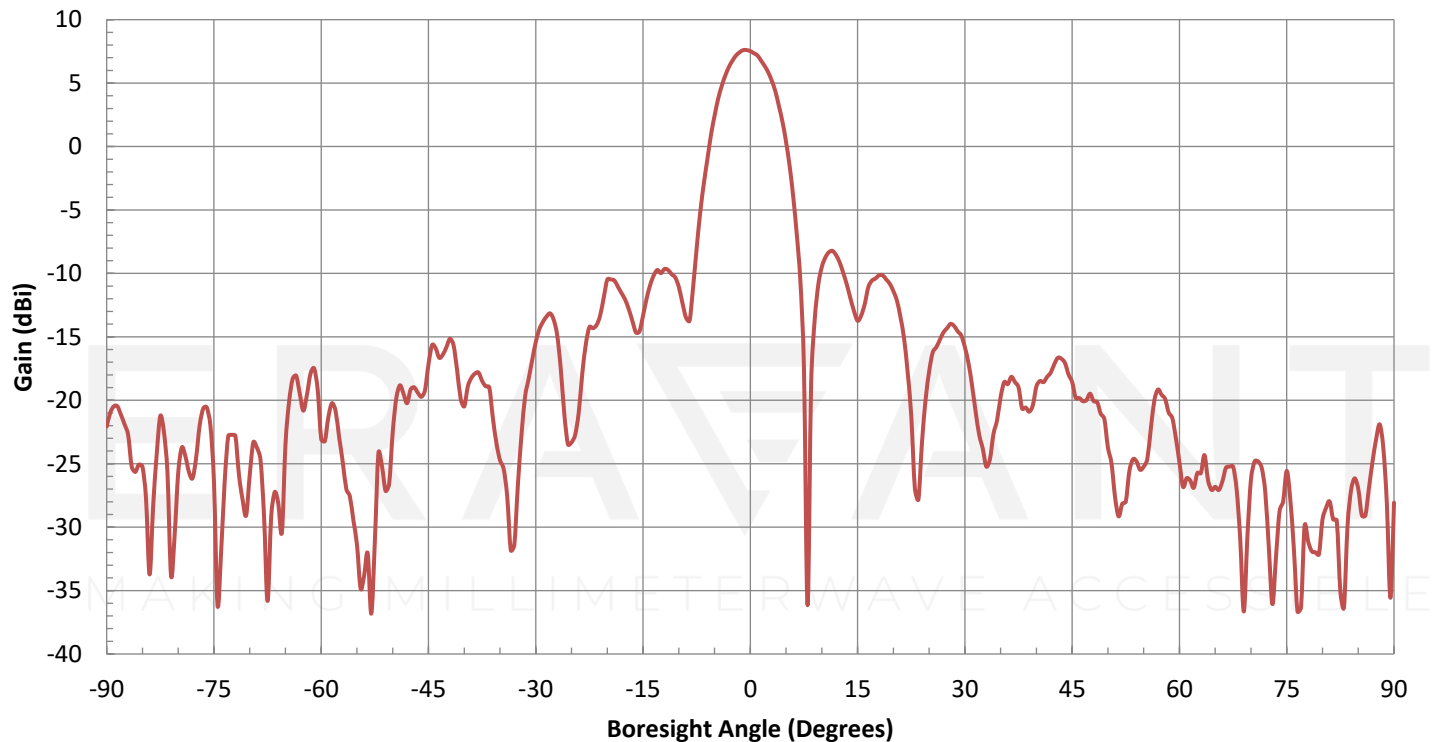

SAO-2734030810-28-S1

## Typical E-Plane Antenna Pattern @ 40 GHz

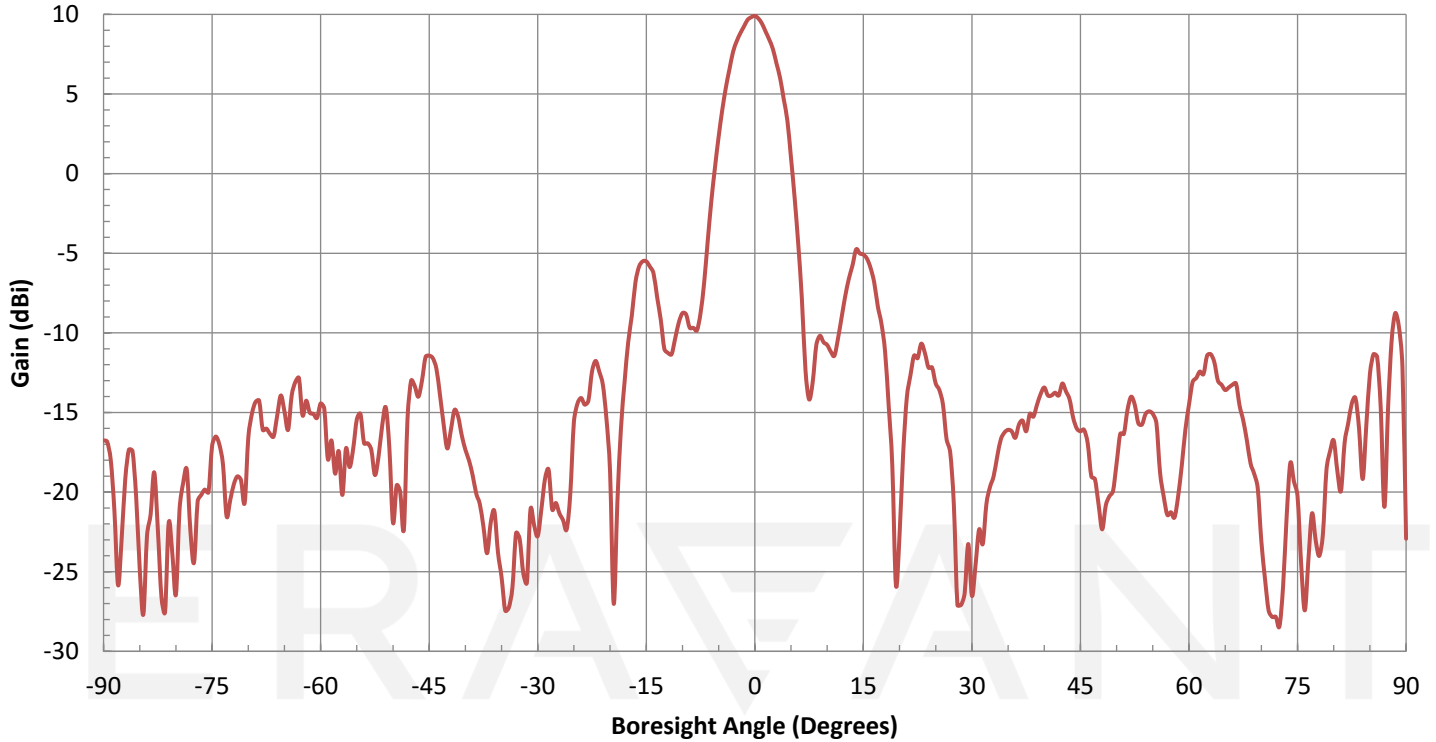

## Typical Gain and Return Loss vs. Frequency

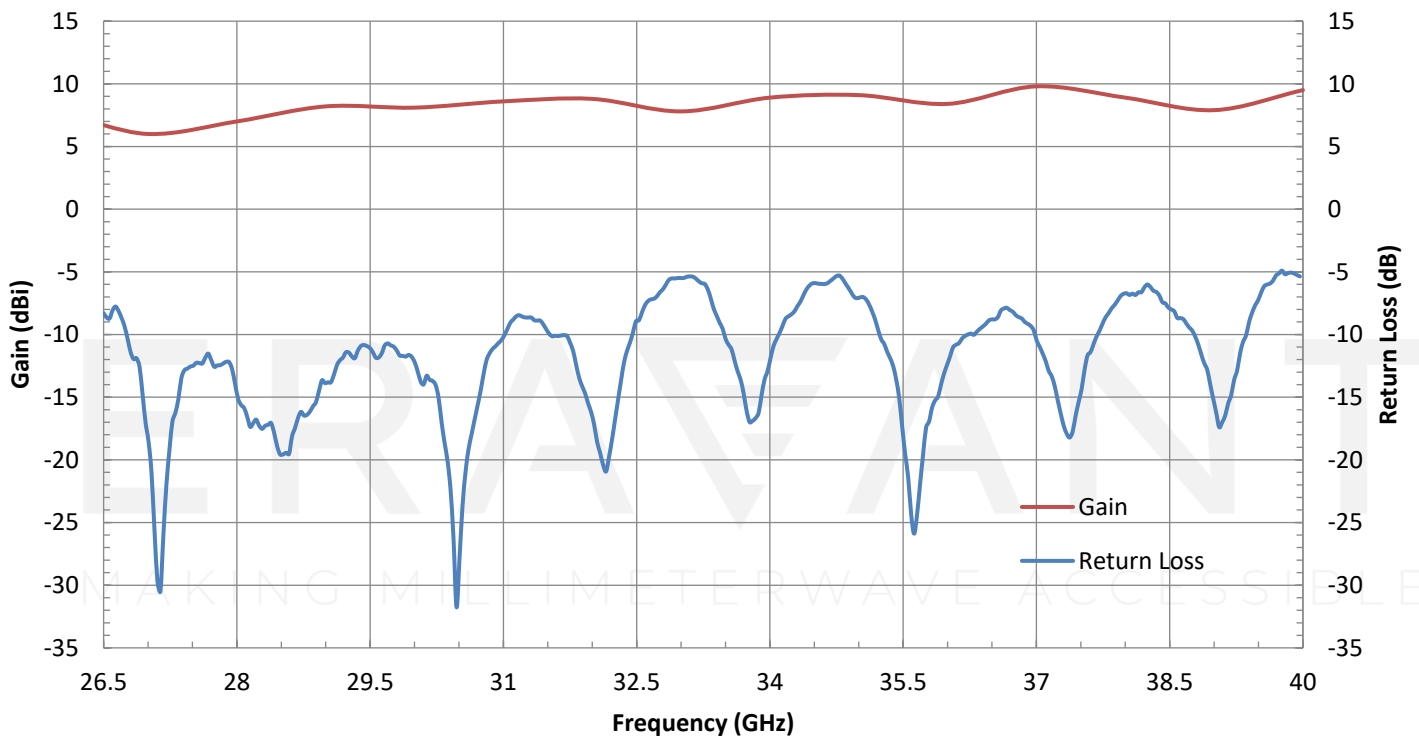

## SAO-2734030810-28-S1

**Mechanical Outline:** (Unless otherwise specified, all dimensions are in inches [millimeters])

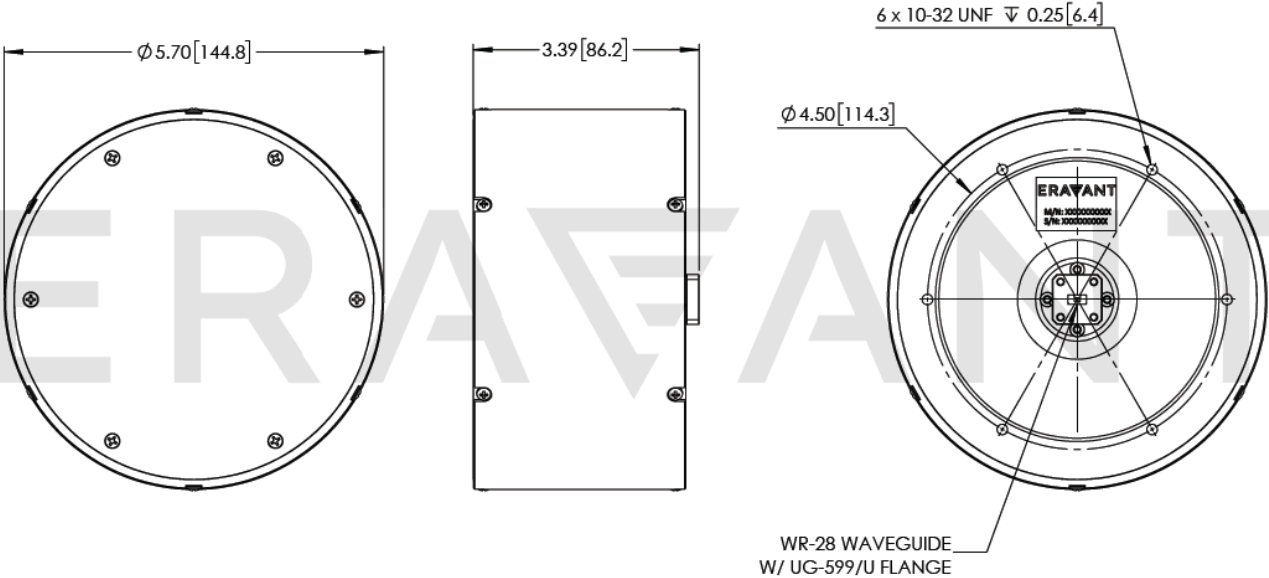

**NOTE:**

- On condition that simulated test data is provided, actual measured data may slightly vary.
- Eravant reserves the right to change the information presented without notice.

**CAUTION:**

- If a waveguide is present, any foreign objects in the waveguide will cause performance degradation and may damage or destroy the unit.