

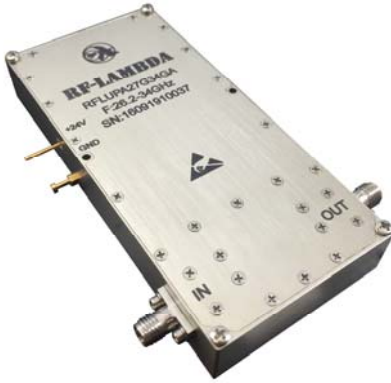

3W Wideband Power Amplifier 32GHz~38GHz



Features

- Wideband Solid State Power Amplifier
- Psat: + 35dBm
- Gain: 32 dB
- Supply Voltage: +24V
- 50 Ohm Matched.

Typical Applications

- Wireless Infrastructure
- Short Haul / High Capacity Links
- RF Microwave and Vsat
- Military & Aerospace Applications
- Test Instrumentation

Electrical Specifications, $T_A = +25^{\circ}\text{C}$, $V_{CC} = +24\text{V}$

Parameter	Min.	Typ.	Max.	Min.	Typ.	Max.	Units
Frequency Range	32 – 34		35 – 38				GHz
Gain		30			32		dB
Gain Flatness		±10			±10		dB
Gain Variation Over Temperature (-45°C ~ +85°C)		±3			±3		dB
Input Return Loss		5			10		dB
Output Return Loss		12			15		dB
Saturated Output Power (Psat)		35			35		dBm
Supply Current (+24 VDC)		1000	2000		1000	2000	mA
Isolation S12		70			70		dB
Input Max Power(no damage)	Psat – Gain		Psat – Gain				dBm
Weight	≈ 650						g
Impedance	50						Ohms
Input / Output Connectors	2.92-Female						
Finishing	Nickel Plated						
Material	Aluminum / Copper						
Package Sealing	Epoxy and Screw Tight Sealing (Standard)						
	Hermetically Sealed (Optional with extra charge)						

* P1dB, P3dB and Psat power test signal: 200µs pulse width with 10% duty cycle.

* For average CW power testing or increased duty cycle, a 5dB back off from Psat is required unless water/oil cooling system is applied.

3W Wideband Power Amplifier 32GHz~38GHz



RF-LAMBDA

The power beyond expectations

RFLUPA32G38GA

Absolute Maximum Ratings	
Supply Voltage	+28Vdc
RF Input Power (RFIN) Pin_max = Psat - Gainsat	Psat – Gain
Storage Temperature (°C)	-50 to +125

Note: Maximum RF input power is set to assure safety of amplifier. Input power may be increased at own risk to achieve full power of amplifier. Please reference gain and power curves.

Biasing Up Procedure	
Step 1	Connect ground
Step 2	Connect input and output with 50 Ohm source/load. (in band VSWR<1.9:1 or >10dB return loss)
Step 3	Connect +24V
Power OFF Procedure	
Step 1	Turn off +24V
Step 2	Remove RF connection
Step 3	Remove ground

Environmental Specifications	
Operational Temperature (°C)	-45 ~ +85 (Case Temperature must be less than 85°C at all times)
Altitude	30,000 ft. (Epoxy Sealed Controlled environment)
	60,000 ft. 1.0psi min (Hermetically Sealed Uncontrolled environment) (Optional)
Vibration	25g RMS (15 degrees 2KHz) endurance, 1 hour per axis
Humidity	100% RH at 35c, 95%RH at 40°C
Shock	20G for 11msec half sine wave, 3 axis both directions

Note: The operating temperature for the unit is specified at the package base. It is the user's responsibility to ensure the part is in an environment capable of maintaining the temperature within the specified limits

Ordering Information		
Part No.	ECCN	Description
RFLUPA32G38GA	EAR99	32GHz~38GHz Power Amplifier

Amplifier Use

Ensure that the amplifier input and output ports are safely terminated into a proper 50 ohm load before turning on the power. Never operate the amplifier without a load. A proper 50 ohm load is defined as a load with impedance less than 1.9:1 or return loss larger than 10dB relative to 50 Ohm within the specified operating band width.

Power Supply Requirements

Power supply must be able to provide adequate current for the amplifier. Power supply should be able to provide 1.5 times the typical current or 1.2 times the maximum current (whichever is greater).

In most cases, RF-Lambda amplifiers will withstand severe mismatches without damage. However, operation with poor loads is discouraged. If prolonged operation with poor or unknown loads is expected, an external device such as an isolator or circulator should be used to protect the amplifier.

Ensure that the power is off when connecting or disconnecting the input or output of the amp.

Prevent overdriving the amplifier. Do not exceed the recommended input power level.

Adequate heat-sinking required for RF amplifier modules. Please inquire.

Amplifiers do not contain Thermal protection, Reverse DC polarity or Over voltage protection with the exception of a few models. Please inquire.

Proper electrostatic discharge (ESD) precautions are recommended to avoid performance degradation or loss of functionality.

What is not covered with warranty?

Each of RF-Lambda amplifiers will go through power and temperature stress testing.

Due to fragility of the die, IC or MMIC, those are not covered by warranty. Any damage to those will NOT be free to repair.

3W Wideband Power Amplifier 32GHz~38GHz



Gain vs. Frequency

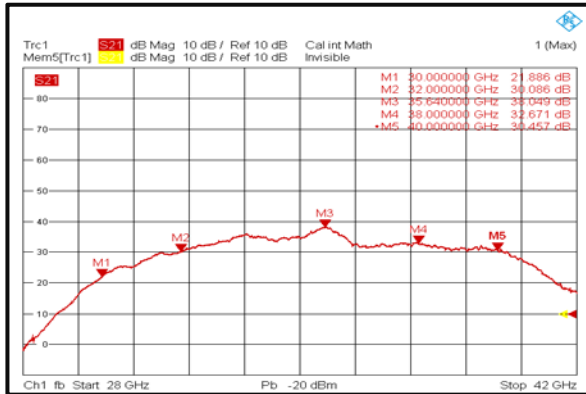

Isolation

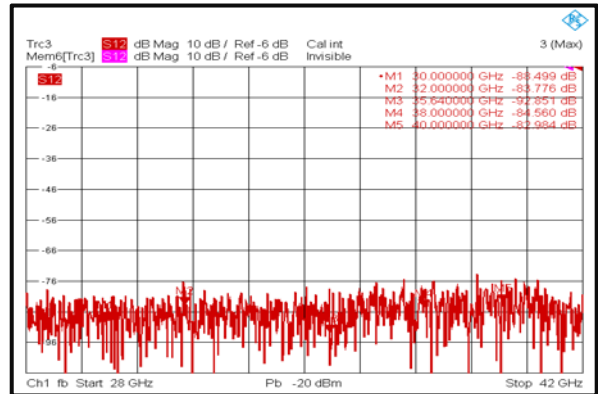

Input Return Loss

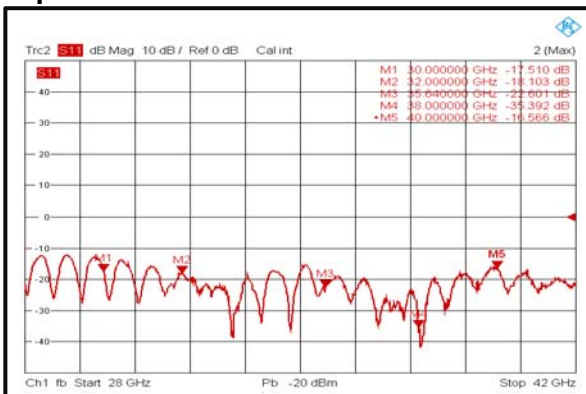

Output Return Loss

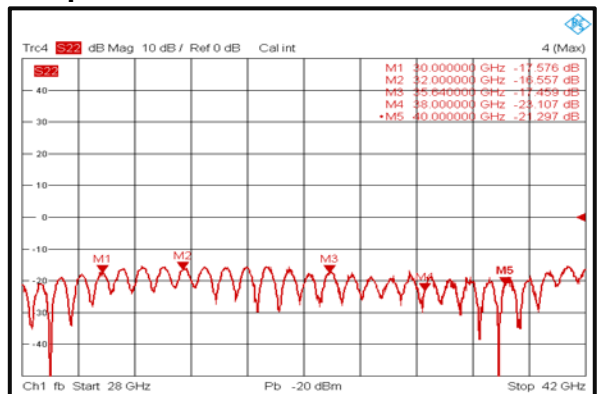

Note: Input / Output return loss measurements include attenuators to protect equipment

3W Wideband Power Amplifier 32GHz~38GHz



RF-LAMBDA

The power beyond expectations

RFLUPA32G38GA

Gain vs. Output Power

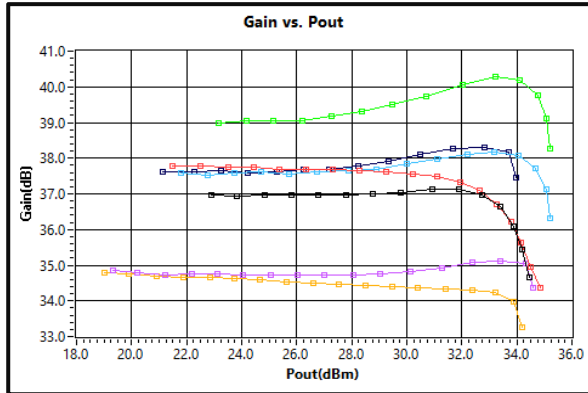

P1dB vs. Frequency

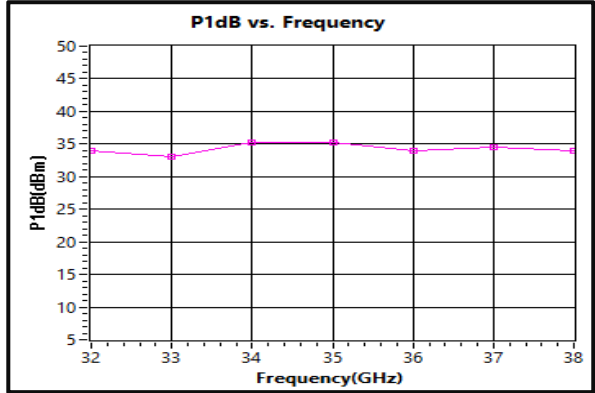

Output Third Order Intercept (IP3)

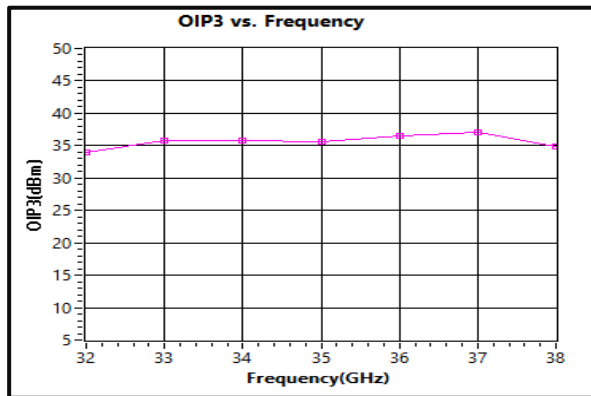

P3dB vs. Frequency

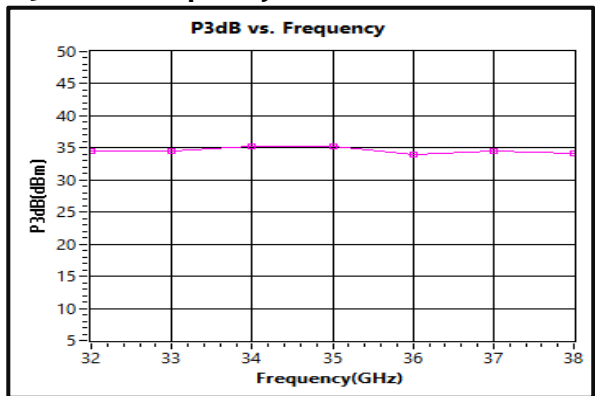

32.0(GHz)	
33.0(GHz)	
34.0(GHz)	
35.0(GHz)	
36.0(GHz)	
37.0(GHz)	
38.0(GHz)	

3W Wideband Power Amplifier 32GHz~38GHz



Outline Drawing:

All Dimensions in mm

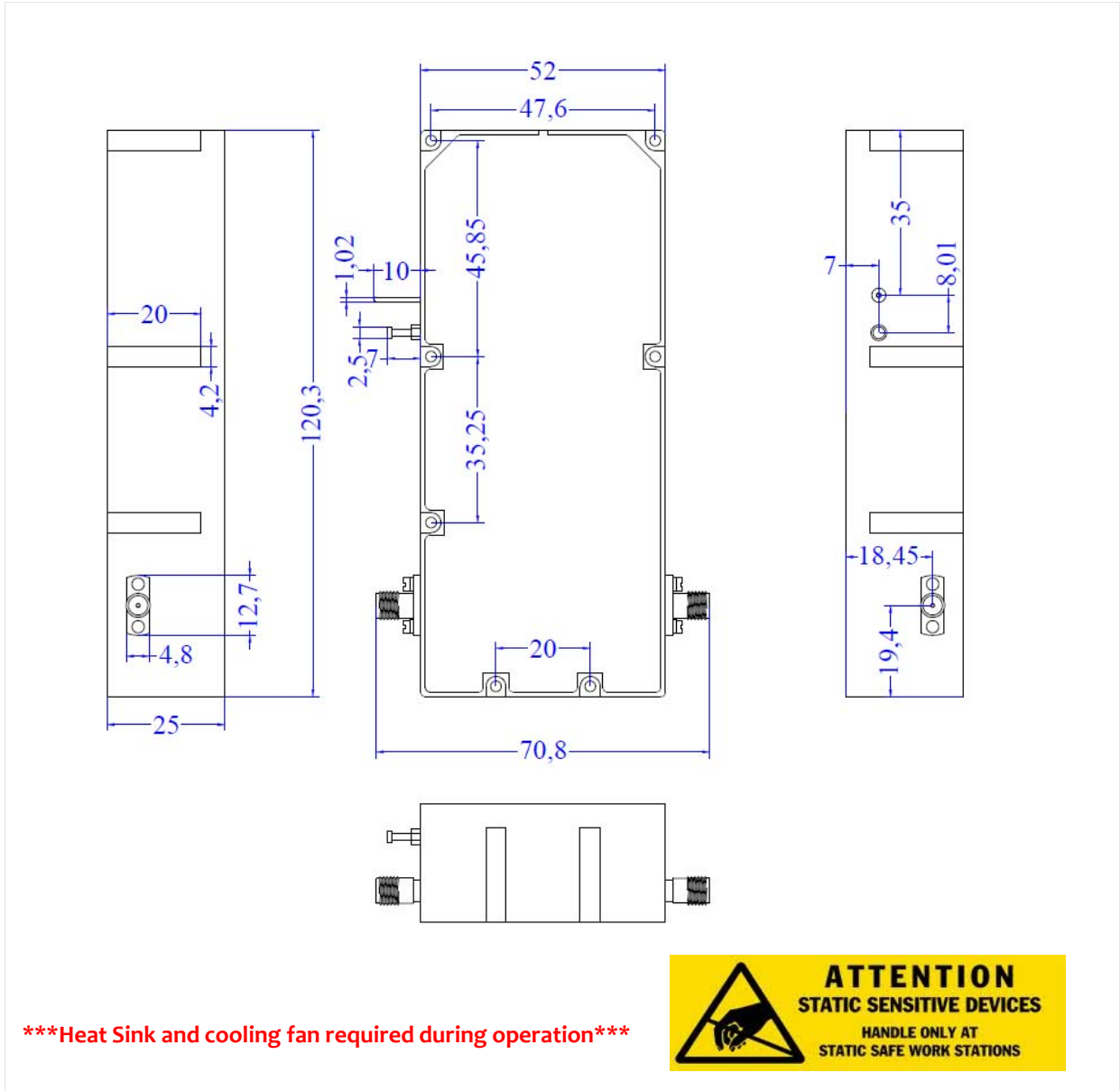



Outline Drawing Heatsink:

All Dimensions in mm

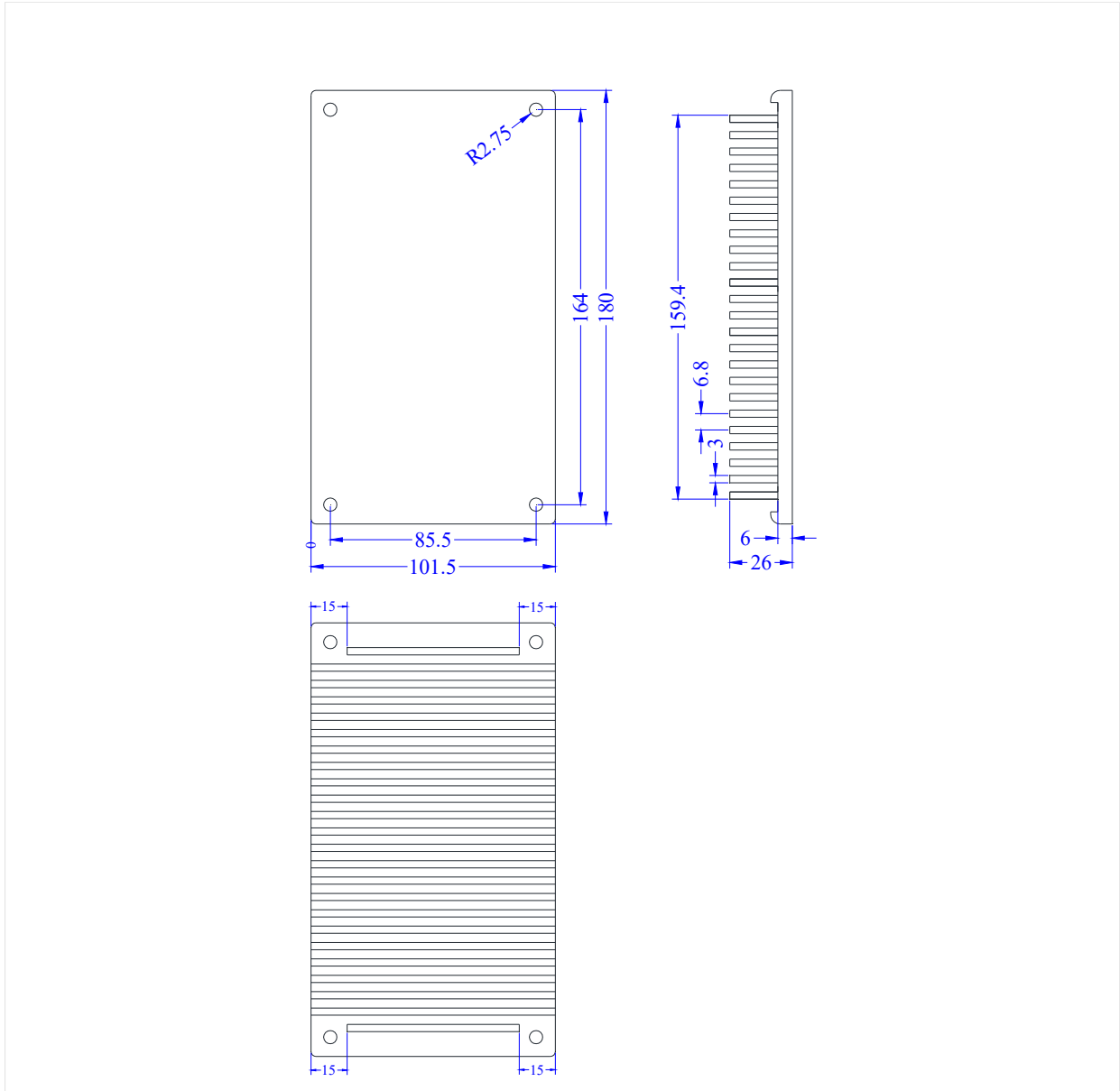



Outline Drawing Heatsink Including Air Cooling:

All Dimensions in mm

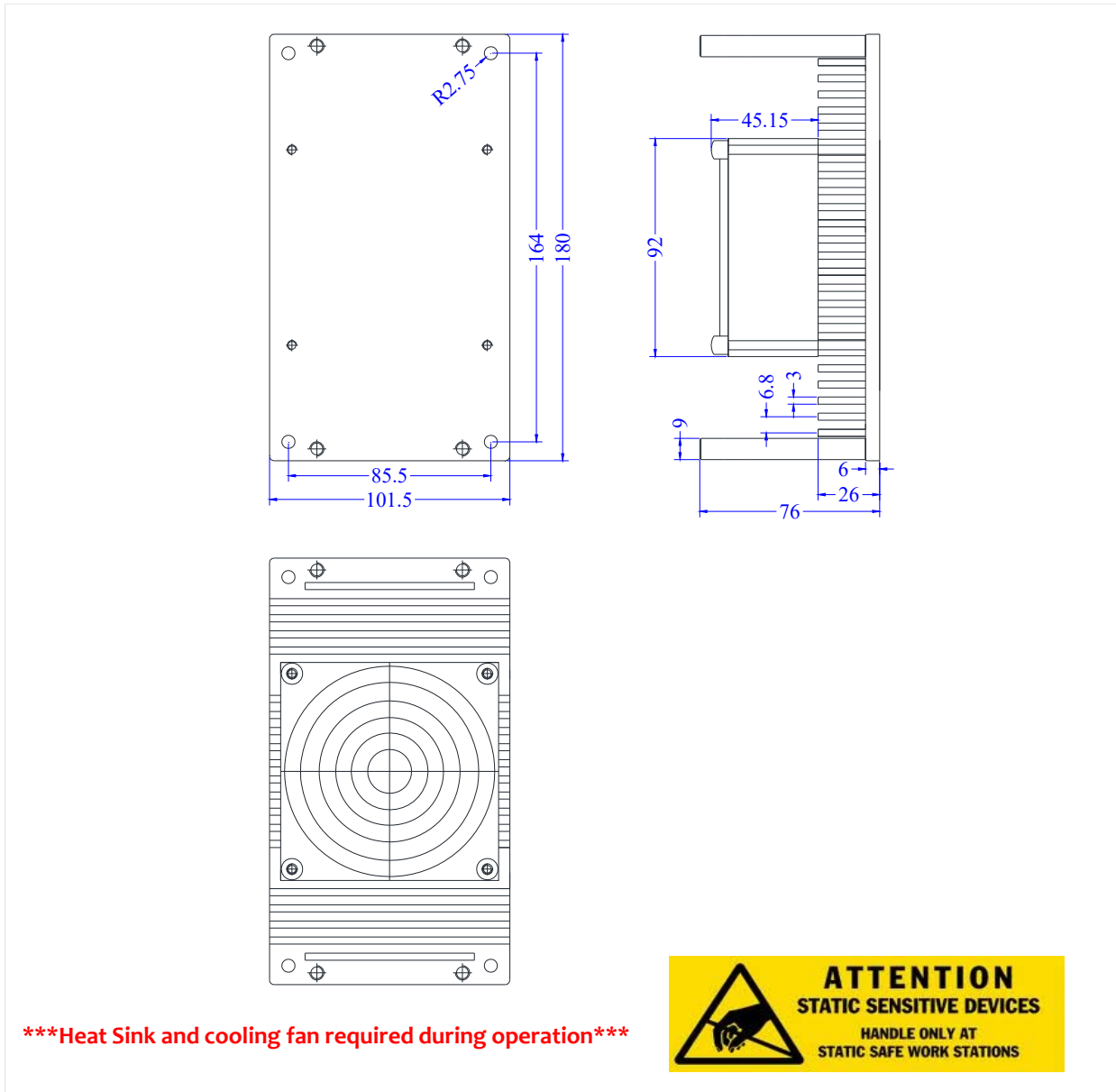

Heat Sink and cooling fan required during operation



Important Notice

The information contained herein is believed to be reliable. RF-Lambda makes no warranties regarding the information contained herein. RF-Lambda assumes no responsibility or liability whatsoever for any of the information contained herein. RF-Lambda assumes no responsibility or liability whatsoever for the use of the information contained herein. The information contained herein is provided "AS IS, WHERE IS" and with all faults, and the entire risk associated with such information is entirely with the user. All information contained herein is subject to change without notice. Customers should obtain and verify the latest relevant information before placing orders for RF-Lambda products. The information contained herein or any use of such information does not grant, explicitly or implicitly, to any party any patent rights, licenses, or any other intellectual property rights, whether with regard to such information itself or anything described by such information.

RF-Lambda products are not warranted or authorized for use as critical components in medical, life-saving, or life sustaining applications, or other applications where a failure would reasonably be expected to cause severe personal injury or death.