

G-Band High Gain Lens Horn Antenna

140 to 220 GHz, WR05, 40 dBi Gain

DESCRIPTION

Anteral's High Gain Lens Horn Antennas are composed by a rectangular waveguide feeder with high quality standard flange that illuminates a **plano-convex** Teflon (PTFE) lens in order to apply phase correction and achieve superior performance with minimum size. The lenses are designed with optimized hyperbolic profile to reduce the aberration to the minimum. The whole system is encapsulated inside an aluminum cylinder that gives high robustness and it counts with a flat side to be the antenna able to stand in a flat surface.

The HGLHA-40-WR05 model operates at the G-band between 140 and 220 GHz with 41.5 dBi nominal mid-band gain and a typical VSWR of 1.5.

APPLICATIONS

High Gain Lens Horn Antennas are especially useful when high gain is required with the minimum size. Therefore, these antennas are widely used in radar applications, communication and meteorological systems among others.

Anteral also offers their **Lens Horn Antennas** that exhibit also high gain (>30 dB) with minimum size at frequencies from 8 to 170 GHz.

ELECTRICAL SPECIFICATIONS

Parameter	Minimum	Typical	Maximum
Frequency	140 GHz	180 GHz	220 GHz
Gain	40.6 dBi	41.5 dBi	42.1 dBi
3 dB Beamwaist, E-plane		1.5 deg	
3 dB Beamwaist, H-plane		1.5 deg	
Sidelobe, E-plane		-33 deg	-25 dB
Sidelobe, H-plane		-34 dB	-31 dB
S11		-14 dB	-11 dB

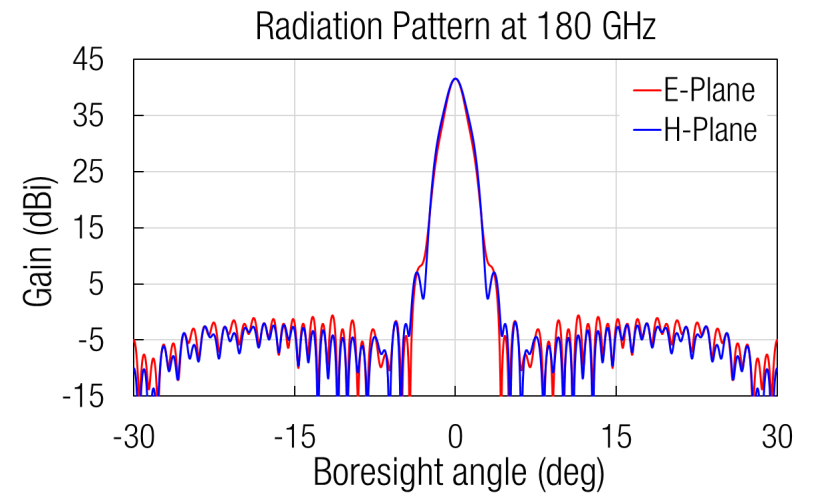
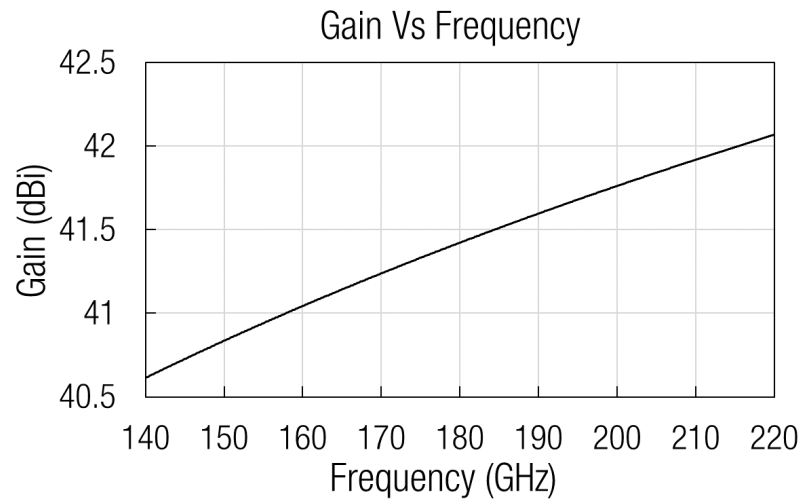

MECHANICAL SPECIFICATIONS

Parameter	Description
Antenna Port*	WR-05 (1.2954 mm x 0.6477 mm)
Flange	UG-387/U
Total length	104.2 mm
Total diameter	118 mm
Total weight	850 g
Horn Material	Aluminum
External Color	Ruby Red

MECHANICAL OUTLINE

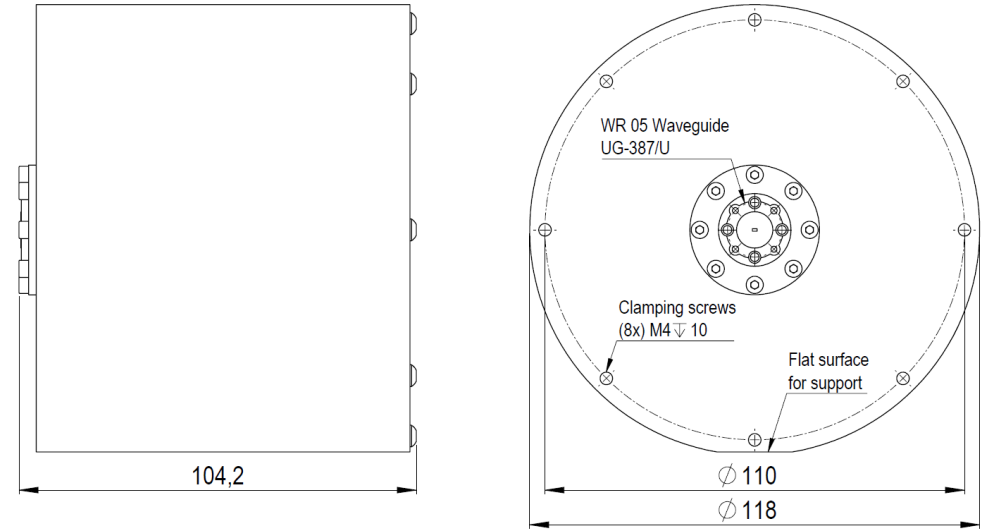

Additional notes

Gain and radiation pattern data are simulated. Actual values could vary slightly.
Return loss data is measured from a sample. Actual values could vary slightly.
The return loss performance of all items is checked before delivery.