

# ALDCBS1X2



## GPS Amplified 1X2 Splitter Technical Product Data

### Features

- Excellent Gain Flatness
  - Less than 1 dB variation between ports.
- Flat Group Delay
  - Less than 1ns variation between L1 and L2.
- High Output Gain
  - 22 dB gain is typical across all operating frequencies.
- Wide Accepted Frequency Range
  - Accepts signals from the entire L-Band, covering all major GNSS constellations.
- Efficiently Blocked Ports
  - Uses 200Ω resistors to prevent antenna alarm faults from connected devices.
- Matched Phase Balance
  - Less than 1° of variation between ports.



### Description

This **Amplified Loaded DC Blocked Splitter 1X2 (ALDCBS1X2)** is an active one input, two output splitter that splits signals from 1.1 GHz to 1.7 GHz. This equipment is designed to amplify and split signals within the L-band to provide two devices with the signal from a single antenna. In the standard configuration, the J1 port will pass DC voltage from a connected device and pass this power to the antenna or other devices upline from the splitter via the antenna port. The other port (J2) is DC blocked and loaded with 200Ω resistors to simulate antenna current draw which prevents antenna alarm faults. Custom gain, DC power, and connector configurations are available upon request.

### Use Cases

- Splitting and amplifying a roof antenna signal between 2 GPS/GLONASS/GNSS receivers.
- Splitting and amplifying WAAS antenna between WASS receiver and ADS-B.
- Splitting and amplifying an antenna signal to 2 passive antennas to re-radiate 2 spaces.
- Usable as a small part of a larger signal distribution network.

# ALDCBS1X2

## Electrical Specifications, TA=25°C



### General Specification

Parameter	Notes	Min	Typ	Max	Unit
Frequency Range	Covers all major GNSS constellations.	1.1		1.7	GHz
Characteristic Impedance	Unused ports should be terminated with 50Ω loads.		50		Ω
Req. DC Input V.	Operating Voltage Range.	3.3		15	VDC
Input P1dB	The 1dB compression point.		-24		dBm
Current Draw <sup>(1)</sup>	Typical current consumption.			23	mA

### GPS L1 & L2 RF Specification

Parameter	Notes	Min	Typ	Max	Unit
Gain	The relative increase in signal power provided by the amplifier.	21	22	23.5	dB
Input SWR	Input Standing Wave Ratio: S11			2.0:1	-
Output SWR	Output Standing Wave Ratio: S22			1.8:1	-
L1 Noise Figure	The increase in noise power relative to an ideal amplifier.		2.5	3.25	dB
Gain Flatness	The difference in loss or gain between the L1 and L2 frequencies.		0.5	1	dB
Amplitude Balance	The difference in gain or loss between each output port.			1.0	dB
Phase Balance	The difference in phase variation between each output port.			1.0	deg
Isolation	The amount of attenuation between two output ports.	L2:15 L1:22			dB
Group delay flatness	The difference in signal delay between the L1 and L2 frequencies.			1	ns
Input P1dB	The 1dB compression point.		-24		dBm
Current Draw	Typical current consumption.			23	mA

External Power Options (Networked Option)		
Source Voltage Options	Voltage Input	Style
	110VAC	Transformer (ITA Type A Wall Mount)
	220VAC	Transformer (ITA Type C Wall Mount)
	240VAC (United Kingdom)	Transformer (ITA Type G Wall Mount)
	Customer Supplied DC 9-32 VDC	Mil DC Connector (Includes Mate)
Output Voltage Options <sup>(1)</sup>	DC Voltage Out	Max Current out For Corresponding Vout
	3.3 V	110mA
	5V	130mA
	9V	140mA
	12V	180mA
	15V	220mA
	Custom	Custom
Standard DC Configuration without External Power Option		
J1/Output 1 Pass DC, J2/Output 2 Block DC, Input Pass DC		
Standard DC Configuration with any External Power Option (AC/DC or Military DC)		
All Outputs DC Blocked with 200Ω load standard		
Any port can be custom selected to Pass or Block DC		
Connector Options	Connector Style	Charge
	Type N-female	No Charge
	Type SMA-female	No Charge
	Type TNC-female	No Charge
	Type BNC-female	No Charge
	Other	Contact GPS Networking

(1)With Network Option, any RF port (input or output) can be specified to Pass DC or Block DC

# ALDCBS1X2

## Part Number Configuration

*Network Option (External Power Supply)  
Requires 'N', Output Voltage and Power Type*

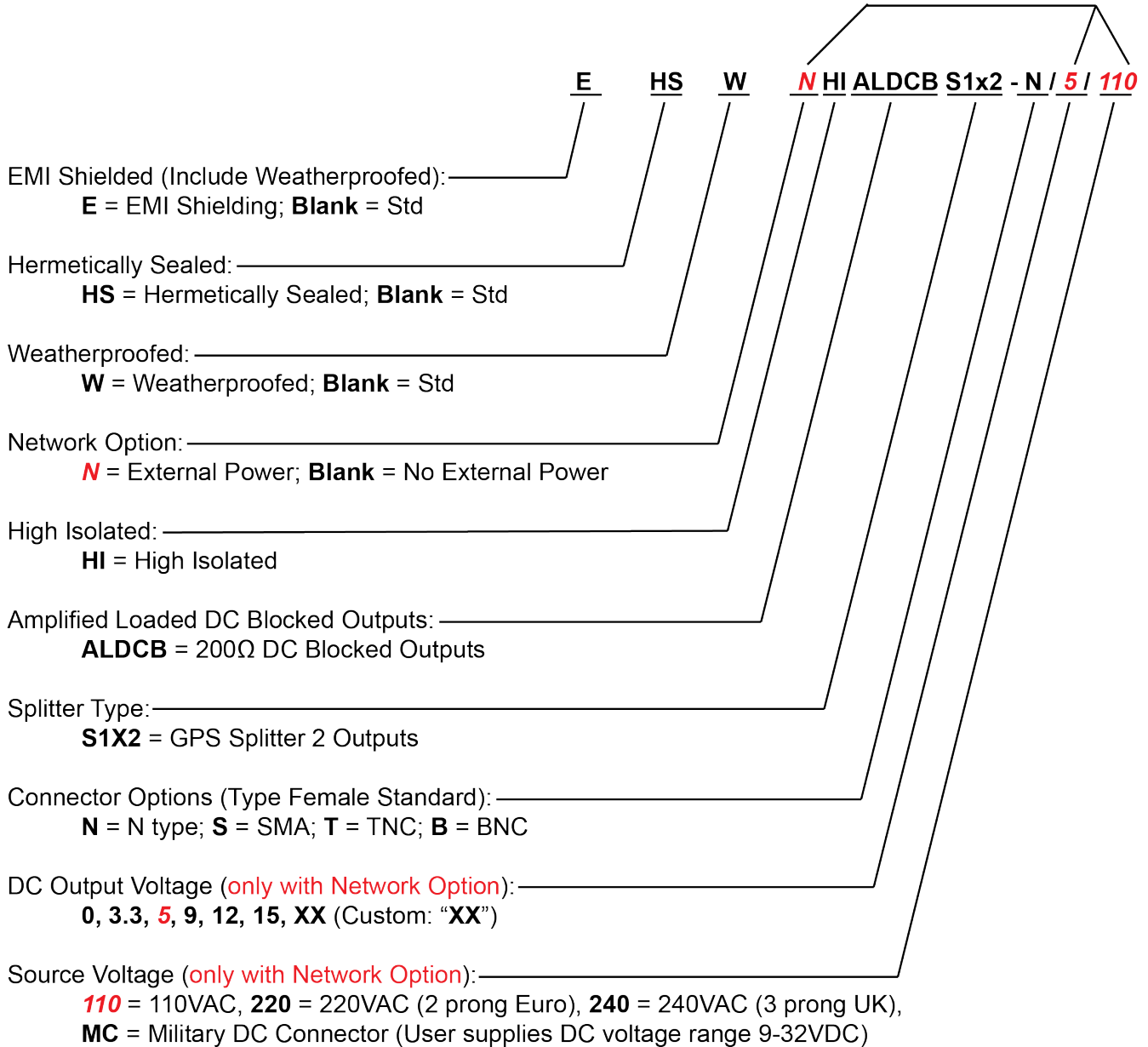

(Military DC Mating Connector is included standard with the MC power option).

When no external power supply option (AC or DC) is selected, Output 1/J1 is Pass DC Standard.  
 When external power supply option is selected, all outputs are DC blocked standard.

Contact GPS Networking Technical Support at 1-800-463-3063 or [salestech@gpsnetworking.com](mailto:salestech@gpsnetworking.com) for any questions regarding non-standard configurations and corresponding part numbers.

# ALDCBS1X2

## Performance



ALDCBS1X2 (Standard Gain, typical)

Each ALDCBS1X2 ships with a test sheet that verifies critical performance characteristics, such as gain, input VSWR, and amplitude balance; a typical VNA test sheet is shown below.



### Test Data

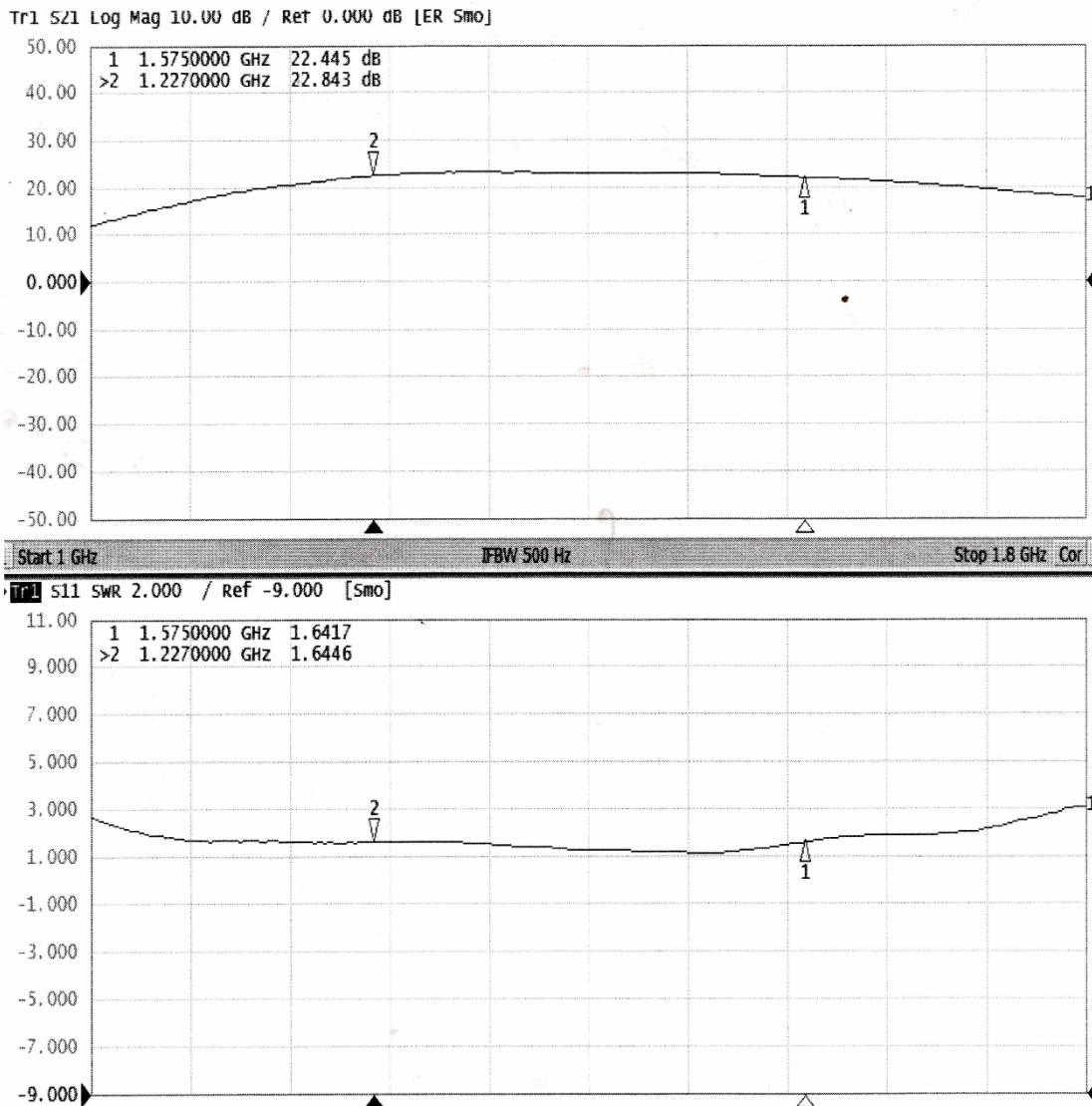

# Mechanical

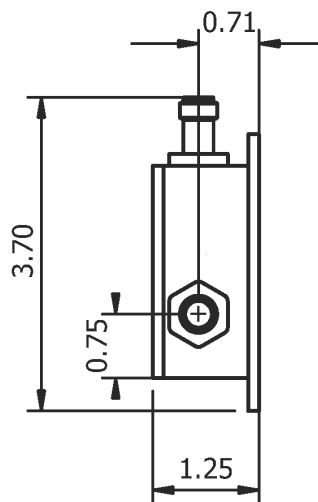
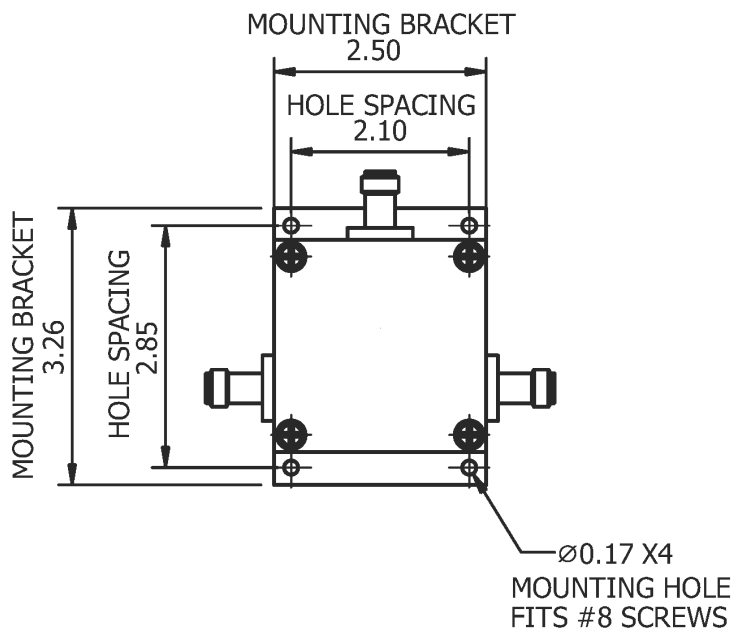
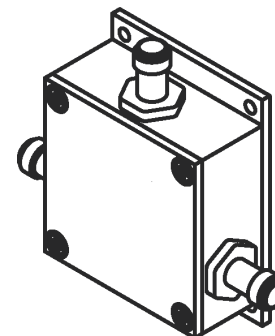
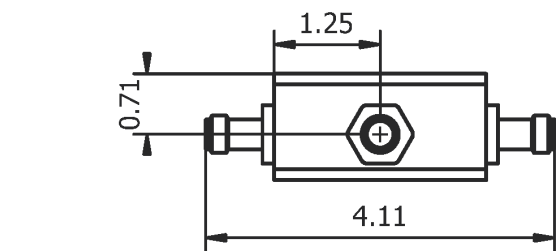

### Mechanical

#### Dimensions:

Depth: 1.3"  
 Height: Body: 2.5"  
 Baseplate: 3.25"  
 Width: 2.5"

Dimensions listed above do not include connectors

Weight: 10.2oz (289g) MAX  
 Maximum weight is with female N-connector option

Weight will vary by connector type  
 Operating Temperature Range: -57°C to +87°C

Housing and Baseplate Finish: Electroless Nickel Plated (MIL-C-26074C, Class 1 0.0001-0.0003 MAX)

Lid Finish: Anodize, Type II, Class 2, Black, per MIL-A-8625

Female TNC connectors shown, other options available  
 EMI shielding may increase dimension by 0.02 inches per axis



373 E. Industrial Blvd  
 Pueblo West, CO 81007

ALDCBS1X2-TNC

Amplified 1X2 GPS Splitter

Tolerances:  
 X±0.030  
 XX±0.015  
 XXX±0.005  
 Angle±1°

6-17-20

NW

Scale: 1:2

Rev: 1

Sheet 1 of 1

Units are inches and degrees