



Product Overview - VNAX Vector Network Analyzer Extension Modules



Virginia Diodes, Inc.

979 2nd St SE, Suite 309
Charlottesville, VA 22902-6172 (USA)

Tel: 434.297.3257

Fax: 434.297.3258

www.vadiodes.com

Contents

General Operating Practices and Recommendations	4
General Guidelines	4
Safety Guidelines.....	4
Waveguide Test Port and RF Cable Care	4
General Operating Practices and Recommendations	4
Vector Network Analyzer Extension Modules	5
VNAX Module Product Specifications	6
VNAX Module General Specifications	7
WR28 to WM250.....	7
WM164	7
Block Diagrams.....	8
Specifications for Alternative Configurations and Options	10
-40 Option (High RF Input Frequency).....	10
-5M Option (+2dBm RF/LO Input Power)	10
-A Option (Integrated Micrometer Driven Output Attenuator).....	11
-DS and -DS3 Option (Dual Source)	12
-P Modules (VNAX Modules for Keysight PXI or Streamline VNAs)	13
-SE Modules (Reduced Performance).....	14
-VVA Option (Voltage Variable Attenuator)	15
-HP Modules (High Power VNAX).....	15
-MS Modules (VNAX with Mixed Signal Input)	15
-M2 (Alternative Form Factor)	17
-TPLX Option (Triplexer Mount)	19
-RXR Module (Dual Rx)	20
Available Configurations and Options.....	21
Product Overview and Accessories	22
WR28 to WM250.....	22
WM164	23
VNAX Module Ordering Notes	23
WR-28 to WM-250 Module Details – Front and Rear Panel Connections	24
WM164 Module Details – Front and Rear Panel Connections	25
VNAX Performance – Dynamic Range and Test Port Power.....	26



Standard System Performances	26
-SE Modules (Reduced Performance).....	34
-DS and -DS3 Option (Dual Source)	35
-MS Modules (VNAX with Mixed Signal Input)	39
-HP Modules (High Power VNAX).....	42
Calibration Kits.....	47
Type A vs. Type B Calibration Kits	47
Calibration Kit Component Care and Handling	47
Waveguide Clamp	47
SOLT and TRL Calibration Kits	48
VNAX Type B Calibration Kit.....	49
VDI VNAX Cable Sets	50
Keysight VNAs	50
Other VNAs	51
High Sensitivity Receiver Option	52
Standard Operation	52
High Sensitivity Operation	52
Enhanced / Effective Dynamic Range for Receivers.....	53
High Sensitivity Receiver Modules	53
Cable Loss Characterization.....	54
AccuTest 150 Attenuation Data	54
Mechanical Drawings	55
Precision Calibration Shim (WR15 and Higher Frequency)	55
Precision Calibration Shim (WR28 to WR19)	56
Precision Calibration Delay	57
VDI-175 Power Supply Specifications.....	58
VDI-175 Power Supply Specifications.....	58
LEMO (10-Pin, 2B) Cable Specifications.....	58
Waveguide Clamps.....	59
Waveguide Clamp Precautions	59



General Operating Practices and Recommendations

General Guidelines

- Read all instructions and information in this manual before connecting an Extension Module to its power supply or a VNA. Operational procedures must be followed for proper function. If you have questions, contact VDI before supplying power to or otherwise operating any VDI Extension Module.
- VDI assumes the customer is familiar with microwave, millimeter wave and VDI products in general. The user is expected to understand all safety guidelines, health hazards and general advisories that may exist and are associated with the use of this product. VDI is not responsible for any human hazards that may exist or may occur while using this device.

Safety Guidelines

- VDI accepts no liability for damage or injury resulting from or caused by:
 - Improper use, disassembly or use for other purposes than for which the product was designed.
 - Use outside common safety, health or general advisories pertaining to microwave, millimeter-wave and VDI products.
 - Repairs carried out by persons other than VDI or its assigned agents.
 - Tampering with or altering power cords or other cabling.
- Use of any attachments and accessories not authorized by VDI or that do not meet VDI's specifications may void a VNA Extension Module's limited warranty and could pose a hazard to the operator or cause lasting damage to the device.
- DC bias cables provided by VDI must be used. Alternative or replacement cables cannot be used unless the DC cables are adequately rated, properly grounded and authorized for use by VDI.
- Disassembling an Extender Module can cause lasting damage to components and pose a hazard to the operator.
- A VNA Extension Module is intended for use only with a power supply module or AC/DC converter supplied with the device by VDI. Use of other power supplies or converters could damage the device or injure the operator.
- Applying liquids (other than the TexWipe wipes / cloths used for cleaning) can cause lasting damage to the module.
- Power inputs to the RF Input and LO Input ports of Extension Modules are noted on labels on every Extension Module. These values provide optimal performance. Irreversible damage can result if input power exceeds stated damage threshold.

Waveguide Test Port and RF Cable Care

- Do not remove the test ports; test ports must be connected with care for optimal RF calibration results.
- Replace dust caps when the system is idle.
- Torque coaxial connections to 90cNm. Avoid sharp bends in cables (RF, IF, LO, etc).
- Inspect waveguide flanges for damage or debris prior to making connections.
- Torque waveguide screws in the range of 20-50cNm when making waveguide flange connections. Greater torque can damage the interface.
- Making a connection with metal debris between the waveguide flanges can damage the waveguide interface and prevent repeatable connections.
- If debris is present, clean the flange with pre-dampened TexWipe wipes or swabs (e.g. Part Number TX1065).
- If these are not available, TexWipe cloths lightly dampened with ethanol may be used (e.g. Part Number TX604).
- Cover test ports with dust caps when the system is idle.

General Operating Practices and Recommendations

- VDI VNA Extension Modules are intended to be used in typical laboratory conditions.
- Check with VDI before any measurement connection is attempted beyond those described in this manual or if it may exceed commonly accepted standards of practice.
- Do not connect or disconnect power cables while the Extender Module is turned on (for VNAX Modules with VDI-175 Power Supplies).



Vector Network Analyzer Extension Modules

VNA Extension Modules from Virginia Diodes deliver high performance network analyzer frequency extension into the THz range. Models operate across full waveguide bands starting at WR-28 (26-40 GHz) to WM-164 (1.1 to 1.5 THz) with products for additional bands in development. In addition to our full Transceiver (TxRx) modules, VDI also offers Transmit-Reference (TxRef) modules and Receive only (Rx) modules that deliver optimized performance for specific applications. These modules combine high test port power and exceptional dynamic range to deliver industry leading performance. They are compatible with most network analyzers and can be integrated into probe stations and antenna chambers. Power leveling and sweeping are also supported when used with our PM5B Power Meter.

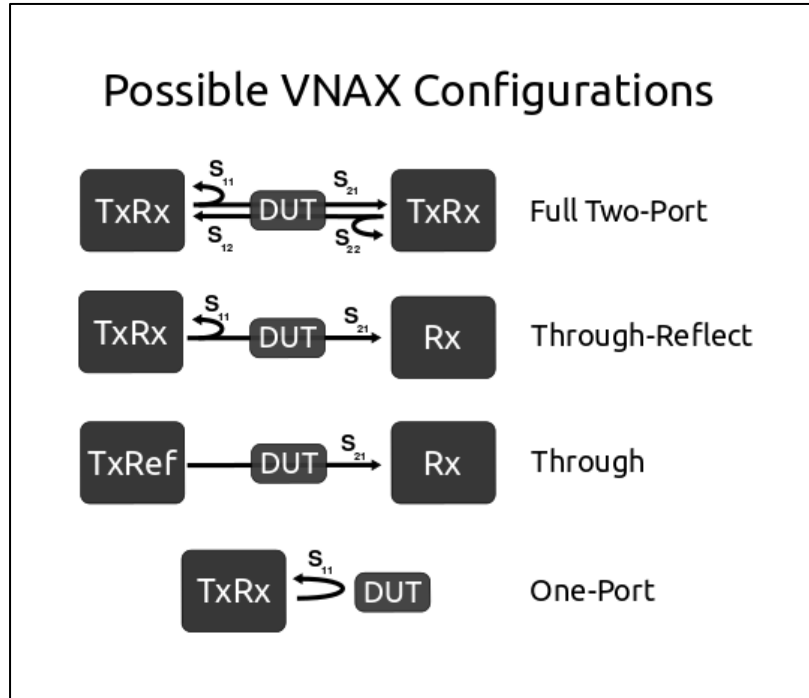

Standard Modules:

TxRx Module

Includes a transmitter, reference receiver, and measurement receiver chains.

TxRef Module

Includes a transmitter and reference receiver chains.

Rx Module

Includes a measurement receiver chain.



VNAX Module Product Specifications

The specifications listed in the table below are for standard configurations. For different configurations and options, please see specifications in the “Available Configurations and Options” section.

Waveguide Band (GHz)	Frequency Band (GHz)		Dynamic Range (BW=10Hz,dB)		Test Port Power (dBm, typ.)	Stability (typical)		Test Port Input Limit (dBm, damage) for TxRx / TxRef / Rx / Rx-HS †	Directivity (dB, typical)
	Standard	Extended [‡]	Typical	Minimum		Magnitude (±dB)	Phase (±deg)		
WR28	26-40	-	120	110	13	0.15	2	33/33/33/0	30
WR22	33-50	-	110	100	13	0.15	2	30/30/23/0	30
WR19	40-60	-	120	105	17	0.15	2	31/31/26/0	30
WR15	50-75	47-77	120	110	18	0.10	1.5	30/30/23/0	30
WR12	60-90	55-95	120	110	18	0.10	1.5	30/30/23/0	30
WR10	75-110	67-115	120	110	18	0.10	1.5	30/30/23/0	30
WR8.0	90-140	-	120	110	16	0.15	2	30/30/23/0	30
WR6.5	110-170	-	120	110	13	0.25	4	30/30/21/0	30
WR5.1	140-220	-	120	110	6	0.25	4	30/30/30/0	30
WR4.3	170-260	-	115	110	4	0.3	4	28/28/30/0	30
WR3.4	220-330	-	115	105	1	0.3	6	26/26/20/0	30
WM-710 (WR2.8)	260-400	-	110	100	-1	0.5	6	23/23/23/0	30
WM-570 (WR2.2)	330-500	325-500	110	100	-3	0.5	6	10/10/10/-10	30
WM-380 (WR1.5)	500-750	-	110*	95*	-12	0.4	4	7/7/7/0	30
WM-250 (WR1.0)	750-1,100	-	95*	75*	-23	0.5	6	-3/-3/-3/-10	30
WM-164 (WR0.65)**	1,100-1,500	-	60*	40*	-45	1	20	-3/-3/-3/-10	30

*The dynamic range specifications assume that low phase noise sources are used, like those used in the modern Keysight PNA / PNA-X analyzers with DDS synthesizers. While compatible, other VNAs may reduce dynamic range. Contact VDI for more information.

**WM164 (WR0.65) performance is specified for a TxRx-Rx configuration. Performance of a TxRx-TxRx configuration is estimated to have a ~15dB degradation of dynamic range and may additionally require the use of a mmWave controller.

†Test Port Input Powers exceeding the peak Test Port Output Power of the TxRx module will compress the module.

Specification Notes:

*Stability is specified for 1hr. after system warm-up, in stable environment with ideal cables.

*Specifications assume a through measurement with two TxRx heads.

*Specifications are measured on a Keysight PNA/PNAX with front panel connection at 25°C typical. Extension modules are compatible with all modern VNAs. Please consult with VDI to discuss VNA and module configurations that will yield the best performance of your application.

*The dynamic range (RBW=10Hz) is measured by first connecting two TxRx modules together and normalizing the un-calibrated S21 & S12. The heads are then disconnected and terminated with a waveguide short. The RMS average of 10 sweeps of the measured S21 & S12 gives the system dynamic range.

*Typical Module Dimensions exclude test port (2" standard test port for all modules except WM250 (WR1.0), where a 1" test port is used).

‡Where noted, Extended Frequency Band applies; module performance within the standard band conforms to standard specifications while performance in the extended regions degrades as follows:

- The minimum and typical dynamic range degrades by 10dB or less compared to the specification of the standard band.

- Typical test port power degrades by 5dB or less compared to the specifications of the standard band.



VNAX Module General Specifications

The specifications listed in the table below are for standard configurations. For different configurations and options, please see specifications in the “Available Configurations and Options” section.

WR28 to WM250

Description		Specification	Connector
RF and LO Input	Typical / Damage	10 dBm ± 3dB / 16 dBm, <20 GHz	2.9mm (f)
IF Outputs (Reference and Measurement)	Maximum, Direct Connection (279 MHz)	-9dBm	2.9mm (f)
	Maximum, Test Set Controller (7.6 MHz)	-21dBm	2.9mm (f)
Test Port	VDI Precision Flange (WR15-WM164)	See Flange Diagram	UG-387/UM
	VDI Square Flange (WR28-WR19)	See Flange Diagram	UG-599/UM
Power Supply	AC Input	100-240VAC, <3.5A, 50-60Hz	U.S. or E.U.
	DC Output	9V / 4A	2.1mm I.D. x 5.5mm O.D. x 9.5mm (f)
Operating Temperature	Typical / Recommended	25°C / 20-30°C	-
Typical Enclosure Dimensions	TxRx & TxRef Module (in.), WR28 to WR19	9.5x3.0x1.5	-
	TxRx & TxRef Module (in.), WR15 to WR1.0	8.5x3.0x1.5	-
	TxRx & TxRef Module (in.), WR15 to WR1.0, -A Option	8.5x3.0x1.5	-
	Rx Modules (in.)	4.75x3.0x1.5	-
Typical Weight	TxRx & TxRef Module (lbs.)	4	-
	Rx Modules (lbs.)	2	-

WM164

Description		Specification	Connector
RF Input	Standard Frequency Input (Typical / Damage)	10 dBm ± 3dB / 16 dBm, <20 GHz	2.9mm (f)
	High Frequency Input (Typical / Damage)	0 dBm ± 3dB / 6 dBm, <45 GHz	2.9mm (f)
LO Input	Typical / Damage (Default)	10 dBm ± 3dB / 16 dBm, <20 GHz	2.9mm (f)
IF Outputs (Reference and Measurement)	Maximum, Direct Connection (279 MHz)	-9dBm	2.9mm (f)
	Maximum, Test Set Controller (7.6 MHz)	-21dBm	2.9mm (f)
Test Port	VDI Precision Flange	See Flange Diagram	UG-387/UM
Power Supply (Sold Separately)	AC Input	100-240VAC, <3.5A, 50-60Hz	U.S. or E.U.
	DC Output	See VDI-175 Datasheet	
Operating Temperature	Typical / Recommended	25°C / 20-30°C	-
Typical Enclosure Dimensions	TxRx & TxRef Module (in.)	11x5x3	-
	Rx Modules (in.)	8x5x3	-
Typical Weight	TxRx & TxRef Module (lbs.)	9	-
	Rx Modules (lbs.)	4	-



Block Diagrams

The block diagrams below illustrate the typical / standard module configurations for TxRx, TxRef and Rx modules. Exact configuration may change if options are added. Contact VDI with any configuration questions.

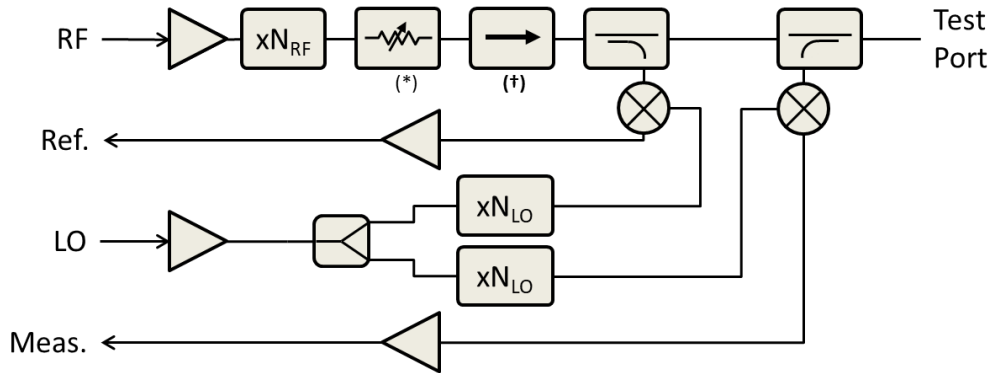

FIGURE 1: TxRx BLOCK DIAGRAM: WR28 TO WM250 (MINI MODULES)

Typical major components in TxRx Extension Modules.

* Variable attenuator (-A Option)

† Isolator (omitted for bands WR2.2 to WR1.0)

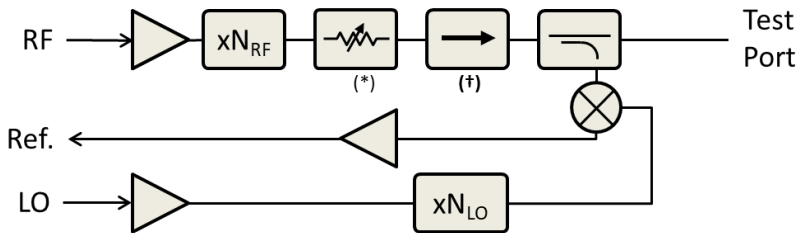

FIGURE 2: TxREF BLOCK DIAGRAM: WR28 TO WM250 (MINI MODULES)

Typical major components in TxRef Extension Modules.

* Variable attenuator (-A Option)

† Isolator (omitted for bands WR2.2 to WR1.0)

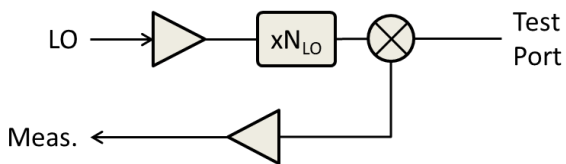

FIGURE 3: Rx BLOCK DIAGRAM: WR28 TO WM250 (MINI)

Typical major components in a Rx Extension Module. This module is shipped with two test ports:

- 1) a fixed attenuator to allow for direct connection to a typical TxRx or TxRef module without damaging the module.
- 2) low loss test port for use in high loss environments (see “Enhanced / Effective Dynamic Range for Receivers” section).



Block Diagrams – continued

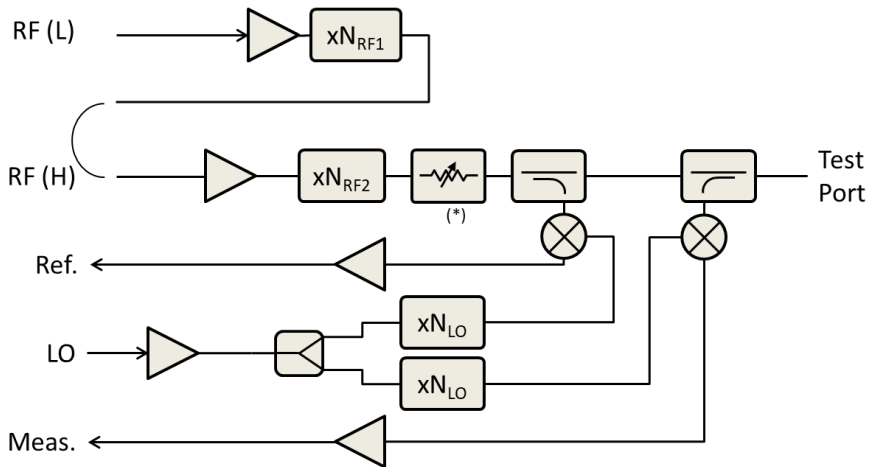

FIGURE 4: TxRx BLOCK DIAGRAM: WM164 (STANDARD SIZE)

Typical major components in TxRx Extension Modules.

* Variable attenuator (not available at this time)

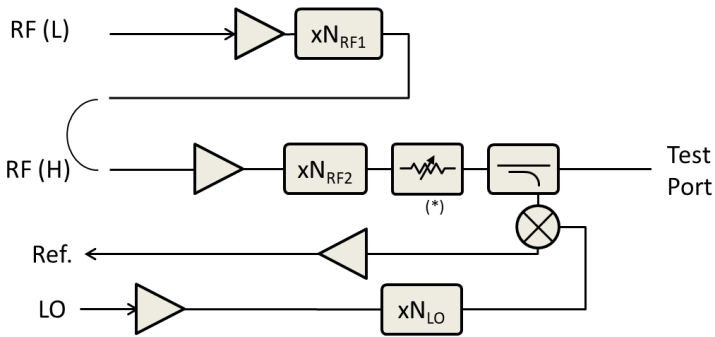

FIGURE 5: TxREF BLOCK DIAGRAM: WM164 (STANDARD SIZE)

Typical major components in TxRef Extension Modules.

* Variable attenuator (not available at this time)

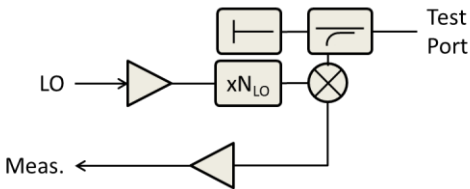

FIGURE 6: Rx BLOCK DIAGRAM: WM164 (STANDARD SIZE)

Typical major components in a Standard Size Rx Extension Module.



Specifications for Alternative Configurations and Options

-40 Option (High RF Input Frequency)

The -40 option configures the VNAX Module with a higher RF input frequency requirement (lower RF harmonic factor). The higher RF input frequency reduces unwanted in-band harmonic signals and may be preferred in some applications.

Configuration	Specifications		
	RF Input Frequency	RF Input Power (Typical / Damage)	RF Input Connector
Standard Configuration	<20 GHz	10dBm ± 3dB / 16dBm	2.9mm(f)
-40 Option	<45 GHz	0dBm ± 3dB / 6dBm	2.4mm(f)

Notes:

- Not recommended with long cable configurations. RF power available after loss of long cable may not be sufficient to drive VNAX with -40 option. External amplification may be required.
- Not recommended for use with the Keysight N5292A Millimeter-wave Test Set Controller. The N5292A is rated up to 20 GHz.

-5M Option (+2dBm RF/LO Input Power)

The -5M option reduces the RF and LO input power requirements. This is recommended for long cable configurations where available RF and LO power after cable loss may not be sufficient to drive the VNAX Modules in the standard configuration.

Configuration	Specifications		
	RF/LO Input Frequency	RF/LO Input Power (Typical / Damage)	RF/LO Input Connector
Standard Configuration	<20 GHz	10dBm ± 3dB / 16dBm	2.9mm(f)
-5M Option	<20 GHz	2dBm ± 3dB / 8dBm	2.9mm(f)

Notes:

- When used in a short cable (~1.2m) configuration, external attenuators on RF and LO input ports may be recommended if VNA port powers cannot be appropriately adjusted to meet the above limits.
- For long cable configurations, VNA port powers may need to be adjusted depending on cable loss.



-A Option (Integrated Micrometer Driven Output Attenuator)

The -A option integrates a micrometer driven variable attenuator for mechanical adjustment of test port power.

Micrometer Rotation:

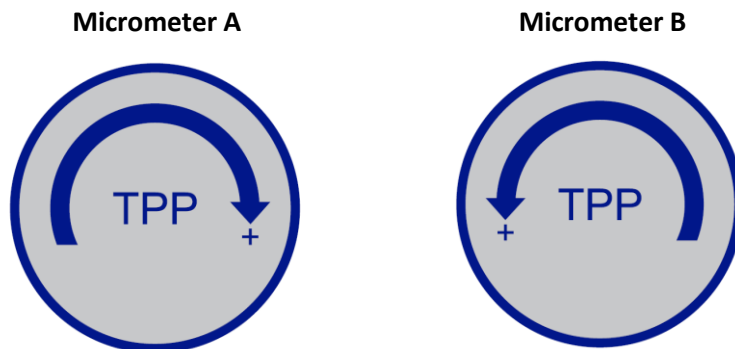

FIGURE 7: PHOTO OF MICROMETER ROTATIONS VS. PERFORMANCE

VNAX Modules with -A Option can include micrometers with different micrometer rotation. Please refer to the sticker on the VNAX Module for proper operation of the micrometer.

Older modules do not include stickers. Alternatively, the user can observe the attenuation vs. rotation by displaying the Reference Receiver trace and observing how the trace changes with micrometer adjustments. Most older modules were shipped with the Micrometer A configuration shown above.

Notes:

- Electronic adjustment of output power may be possible depending on VNA configuration (e.g. Source Power Calibration on VNA). For voltage controlled attenuators, see -VVA Option.
- For widest adjustable range in test port power, VDI recommends -A option and using electronic power control through the VNA software.
- Available from WR-15 to WM-250 bands. The -A option will reduce Test Port Power and Dynamic Range as specified in the table below. Specifications are subject to change. Please refer to the VNAX Manual shipped with your module.

-A Option	TPP and DR Reduction (Compared to Standard Specifications, dB)*						
	WR15-WR6.5	WR5.1-WR4.3	WR3.4	WM710	WM570	WM380	WM250
Frequency Band	1dB	2dB	1dB	3dB	2dB	3dB	6dB

*Older WM570-WM250 -A modules may have shipped with micrometers with higher insertion loss.



-DS and -DS3 Option (Dual Source)

The -DS and -DS3 option integrates a 2nd transmitter chain and directional coupler into a standard TxRx or TxRef module. This enables two-tone measurements to allow users to characterize device linearity / compression. The -DS option includes a 6dB combining coupler and the -DS3 option includes a 3dB combining coupler. With the -DS3 option, the Test Port Power imbalance between Source 1 and Source 2 is reduced while sacrificing maximum available test port power compared to the standard (6dB coupler) configuration.

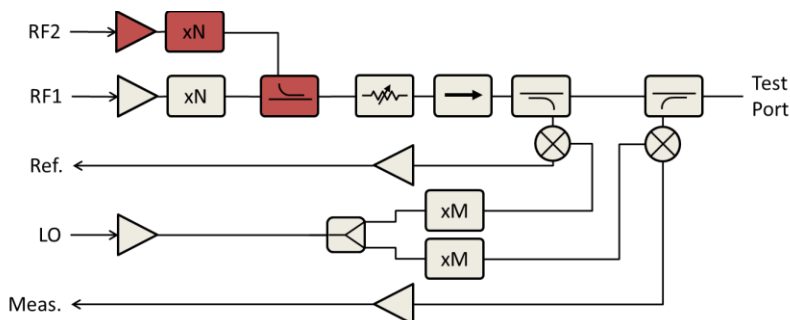

FIGURE 8: SIMPLIFIED BLOCK DIAGRAM OF THE VNAX-DS MODULE. COMPONENTS IN RED ARE SPECIFIC TO THE VNAX-DS MODULE AND NOT INCLUDED IN STANDARD VNAX MODULES (WITHOUT DS OPTION).

Configuration	Frequency Band (GHz)		Dynamic Range (BW=10Hz, dB)**		Test Port Power (dBm, typ.)	
	Standard	Extended*	Typical	Minimum	Source 1	Source 2
WR15 (-DS)	50-75	47-77	115	105	15	10
WR15 (-DS3)			115	105	13	13
WR12 (-DS)	60-90	55-95	115	105	14	9
WR12 (-DS3)			115	105	13	13
WR10 (-DS)	75-110	67-115	115	105	16	11
WR10 (-DS3)			115	105	13	13
WR8.0 (-DS)	90-140	-	110	100	12	7
WR8.0 (-DS3)			110	100	10	10
WR6.5 (-DS)	110-170	-	110	100	12	7
WR6.5 (-DS3)			110	100	10	10
WR5.1 (-DS)	140-220	-	110	100	3	-2
WR5.1 (-DS3)			110	100	1	1

*See VDI website for expected performance degradation in the Extended Band.

**Applies to RF1 chain and when connected to a standard configuration VNAX module.

Notes:

- Can be configured with -40 and -5M options.
- The configuration includes the -A option by default. The -A option can be removed upon request.
- Higher frequency and higher power modules may be available upon request.
- Contact VNA manufacturer to confirm required hardware and software options for IMD / TOI measurement.



-P Modules (VNAX Modules for Keysight PXI or Streamline VNAs)

The VNAX-P modules are configured specifically for use on a Keysight PXIe or Streamline USB VNA in a direct connect configuration.

Part Number	Frequency Band (GHz)		Test Port Power (dBm, typ.)	Dynamic Range (BW=10Hz, dB)		Stability	
	Standard	Extended		Typical	Minimum	Magnitude (\pm dB)	Phase (\pm deg)
WR15VNAXTXRXM-P	50-75	-	13	105	95	0.15	2
WR12VNAXTXRXM-P	60-90	-	13	105	95	0.15	2
WR10VNAXTXRXM-P	75-110	-	16	105	95	0.15	2
WR10VNAXTXRXM-SE-P	75-110	-	-4	105	95	0.15	2
WR6.5VNAXTXRXM-P	110-170	-	13	95	85	0.4	6

VNAX-P Port	Specifications	Comments
RF Input Power (Typical / Damage)	+2dBm / +8dBm	VNA Output Power adjustable on some Streamline VNAs
LO Input Power (Typical / Damage)	-10 to +5dBm / +17dBm	
LO Output Power (Typical)	+4dBm (est.)	LO Output (LO-O) Port should be terminated when not in use.
Ref. IF Output	0dBm max, 4-13 MHz	Fixed; Exact IF Frequency depends on Streamline / PXI VNA models
Meas. IF Output	0dBm max, 4-13 MHz	Fixed; Exact IF Frequency depends on Streamline / PXI VNA models

Notes:

- For use with P50xxA/B, M980xA, P93xxA/B or P937xA Keysight VNAs. Contact Keysight for required hardware and software options.
- For Streamline / PXIe VNA Setup Instructions, please refer to Keysight's N5252-90002 User Guide.
- For measurements above 110 GHz and up to 330 GHz, VDI recommends using a Keysight P50xxA/B or M980xA with a VNAX-AM (Streamline/PXIe VNA to VDI VNAX Adapter Module) and standard VDI VNAX modules.
- Cannot be configured with any other options (-40, -5M, -A, -DS, -DS3, etc).
- TxRef and Rx Modules are also available. Test Port Power specification for the TxRef module is the same as the TxRx module. Standard and Extended frequency ranges apply for TxRx, TxRef and Rx modules.
- **A 50 Ω termination is required when the LO Output (LO-O) Port is not in use.**



-SE Modules (Reduced Performance)

The VNAX-SE modules have reduced performance and functionality compared to standard VNAX modules.

Part Number	Frequency Band (GHz)		Test Port Power (dBm, typ.)
	Standard	Extended	
WR15VNAXTXRXM-SE	50-75	47-77	13
WR12VNAXTXRXM-SE	60-90	55-90	13
WR10VNAXTXRXM-SE	75-110	67-110	-4

Notes:

- TxRef and Rx Modules are also available. Test Port Power specification for the TxRef Module is the same as the TxRx module. Standard and Extended frequency ranges apply for TxRx, TxRef and Rx modules.
- Can be configured with -40, -5M, and -A options.
- Refer to the standard VNAX specification table for other performance specifications.

-EB Modules (Extended Band)

The VNAX-EB Module offers extended band performance. The -EB module is currently only available at WR5.1. Extended band performance is available on some standard VNAX modules. For the WR5.1 unit, upgrades are required to improve the standard performance down to 130 GHz.

Part Number	Frequency Band (GHz)		Extended Band Test Port Power (dBm, typ.)	Extended Band Dynamic Range (typ. / min.)
	Standard	Extended		
WR5.1VNAXTXRXM-EB	140-220	130-220	1	110 / 95

Notes:

- TxRef and Rx Modules are also available. Test Port Power specification for the TxRef Module is the same as the TxRx module. Standard and Extended frequency ranges apply for TxRx, TxRef and Rx modules.
- Can be configured with -40, -5M, and -A options.
- Refer to the standard VNAX specification table for other performance specifications.



-VVA Option (Voltage Variable Attenuator)

The -VVA option adds a voltage controlled variable attenuator into the transmitter path for electronic control of the VNAX test port power up to ~30dB. This is available at WR-10 and WR-6.5. Other bands may be available upon request. Module length may increase up to ~2 inches compared to the standard module.

Notes:

- Can be configured with -40 and -5M options.
- Refer to the standard VNAX specification table for other performance specifications.

-HP Modules (High Power VNAX)

VDI offers VNAX modules with higher test port power compared to the standard VNAX modules. The High Power VNAX modules conform to all other standard performance specifications. The typical and minimum dynamic range may be slightly reduced. Enclosure dimensions may increase for some options. Contact VDI for more information.

Waveguide Band	RF Freq. (GHz)	Part Number	Test Port Power (typ., est.)
WR-12	60-90	WR12VNAXTxRxM-HP4	24
WR-10	75-110	WR10VNAXTxRxM-HP2	21
		WR10VNAXTxRxM-HP4	24
WR-8.0	90-140	WR8.0VNAXTxRxM-HP8	27
WR-6.5	110-170	WR6.5VNAXTxRxM-HP2	17
		WR6.5VNAXTxRxM-HP4	20
WR-5.1	140-220	WR5.1VNAXTxRxM-HP	8
WR-4.3	170-260	WR4.3VNAXTxRxM-HP	12
		WR4.3VNAXTxRxM-HP4	17
WR-3.4	220-330	WR3.4VNAXTxRxM-HP	3
WM-380 (WR-1.5)	500-750	WM-380(WR-1.5)VNAXTxRxM-HP	-7

Notes:

- TxRef Modules are also available. Test Port Power specification for the TxRef Module is the same as the TxRx module.
- Can be configured with -40, -5M, and -A options.
- Refer to the standard VNAX specification table for other performance specifications.

-MS Modules (VNAX with Mixed Signal Input)

The VNAX-MS Module adds a second RF path into the standard TxRx Module (see block diagram below) to allow the injection of external signals into the TxRx Module. Both the internal signal (RF1) and the external signal (RF2) are sampled by the couplers. RF1 consists of a standard VNA transmitter that can be used to perform calibrated S-parameter measurements. The signal for RF2 must be supplied by an external extender, for example a VDI SGX or CCU module. This allows the injection of either a single tone or a wideband modulated signal. The wideband modulated signal can be characterized and corrected using a calibration done using RF1, thus



enabling the generation of broadband signals at the output Test Port with exceptional flatness and phase accuracy. At some frequency bands, VNAX-MS modules have reduced test port power and dynamic range compared to standard VNAX modules.

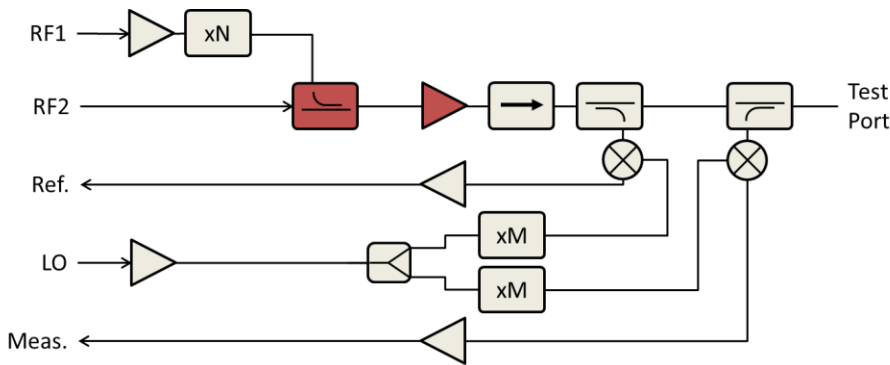

FIGURE 9: SIMPLIFIED BLOCK DIAGRAM OF THE VNAX-MS MODULE. COMPONENTS IN RED ARE SPECIFIC TO THE VNAX-MS MODULE AND NOT INCLUDED IN STANDARD VNAX MODULES (WITHOUT MS OPTION). A WAVEGUIDE AMPLIFIER IS INCLUDED FOR WR-15 TO WR-6.5 VNAX-MS MODELS.

VNAX-MS Specifications							
Waveguide Band (GHz)	Frequency Band (GHz)		Dynamic Range (BW=10Hz,dB)**	Source 1 (RF1) Test Port Power (dBm, typ.)	Source 2 (RF2)		
	Standard	Extended*			Typical / Minimum	Path Gain (RF2 to Test Port, dB, typ.)†	Output P1dB (dBm, typ., est.)††
WR15	50-75	47-77	120 / 110	18	18 (est.)	9	-19 / +10
WR12	60-90	55-95	120 / 110	18	15	14	-12 / +10
WR10	75-110	67-115	120 / 110	18	15	14	-11 / +10
WR8.0	90-140	-	120 / 110	16	18	11	-18 / +10
WR6.5	110-170	-	115 / 105	13	16	9	-17 / +10
WR5.1	140-220	-	110 / 100	-2	-6	N/A	+10 / >+20
WR4.3	170-260	-	115 / 105	-6 (est.)	-6 (est.)	N/A	+8 / >+20
WR3.4	220-330	-	105 / 95	-10	-8	N/A	+6 / >+20

*See VDI website for expected performance degradation in the Extended Band.

**Assumes VNAX-MS Module is paired with a modern VNAX Module. Dynamic range may be reduced when paired with modules with reduced test port power.

†Negative Path Gain = Loss; Where available (up to WR6.5), waveguide amplifiers are included, to provide gain from RF2 to the Test Port.

††Only applies for VNAX-MS Modules with waveguide amplifiers (up to WR6.5).

Contact VDI for enclosure dimensions for VNAX-MS modules.

Contact Keysight for more information on full system configuration.



-M2 (Alternative Form Factor)

The -M2 option configures the TxRx module with an alternative form factor. It is wider and shorter than the standard TxRx module.

Notes:

- Can be configured with the -5M option.
- The -A option is not available in the M2 form factor. Contact VDI for more information.

WR6.5 – WR15:

THE INFORMATION CONTAINED IN THIS DOCUMENT IS THE PROPRIETARY PROPERTY OF VIRGINIA DIODES, INC.

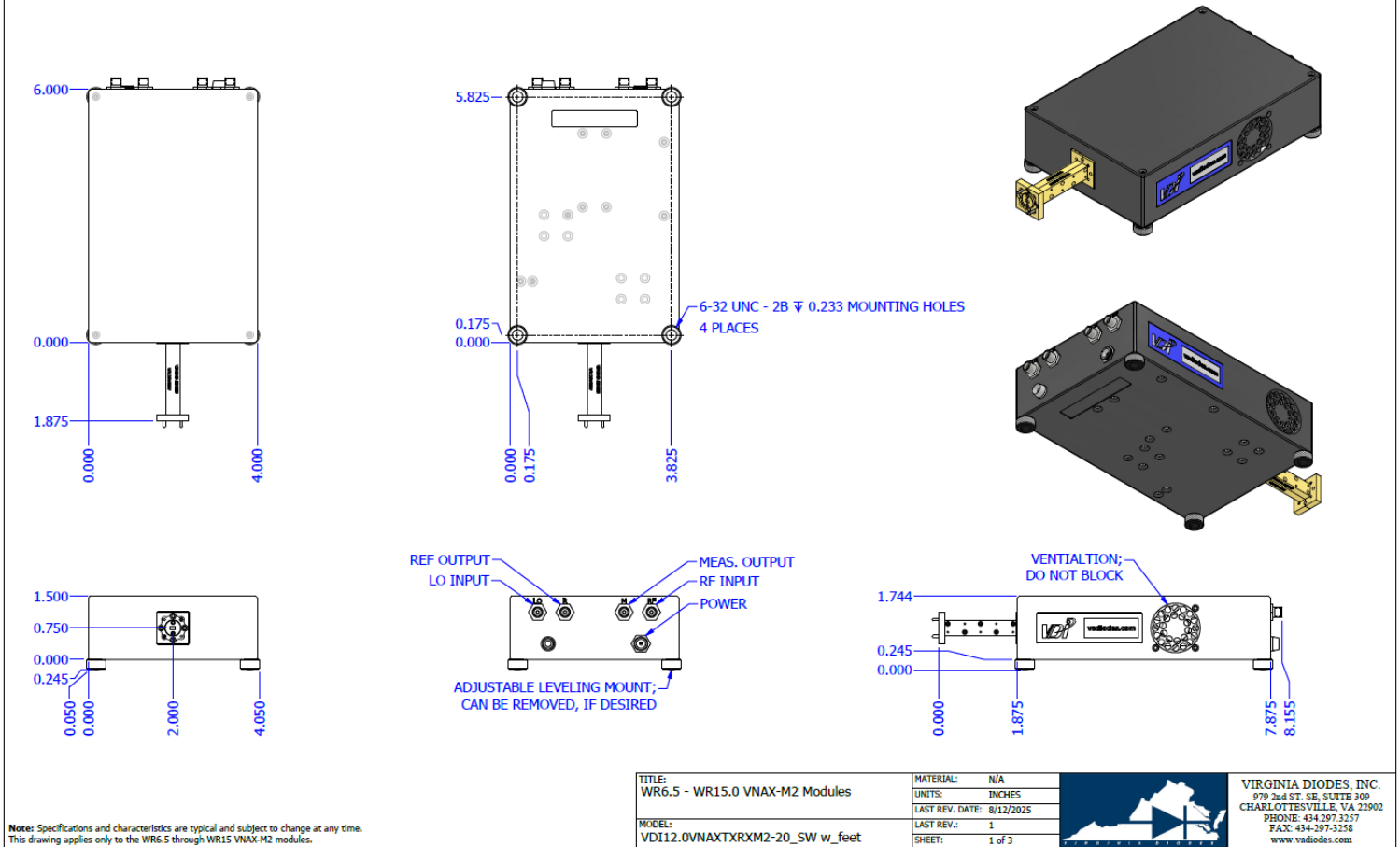

THE INFORMATION CONTAINED IN THIS DOCUMENT IS THE PROPRIETARY PROPERTY OF VIRGINIA DIODES, INC.

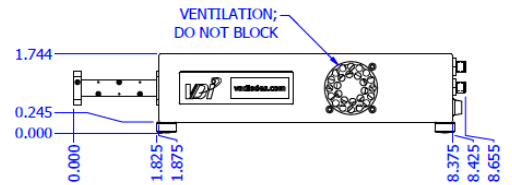
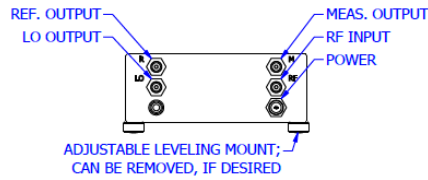
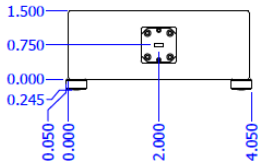
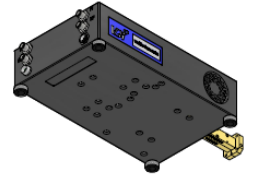
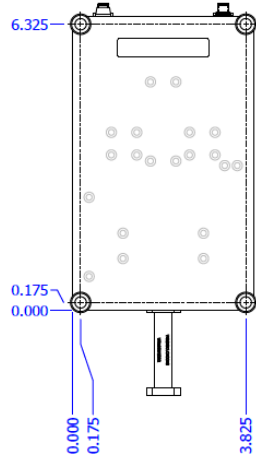
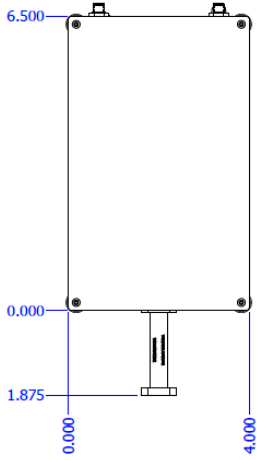

Notes: Specifications and characteristics are typical and subject to change at any time.
This drawing applies only to the WR19.0 VNA-M2 modules.

TITLE: WR19 VNA-M2 Module	MATERIAL: N/A
UNITS: INCHES	LAST REV. DATE: 1/30/2026
MODEL: VDI19.0VNAXTRXM2-20 with Feet	LAST REV.: 1
	SHEET: 1 of 3



VIRGINIA DIODES, INC.
979 2nd ST. SE, SUITE 309
CHARLOTTESVILLE, VA 22902
PHONE: 434-297-3257
FAX: 434-297-3258
www.vadiodes.com



-TPLX Option (Triplexer Mount)

The -TPLX option configures the Rx module with mounting holes to allow the user to mount a triplexer to the top of the Rx module. Standard Rx modules do not have mounting holes. The triplexer is sold separately and not included with this option. VDI will ship a 15V Power Supply for certain Rx modules configured with the Triplexer Option. A 9V Power Supply is included for standard Rx operation.

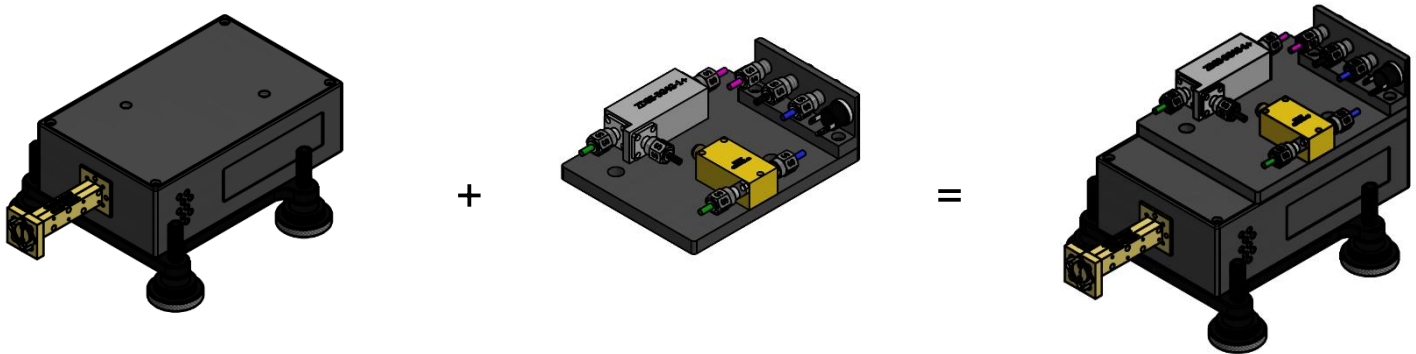

FIGURE 10: PHOTO OF TRIPLEXER (SOLD SEPARATELY) MOUNTING ON RX MODULE. THE RX MODULE WITH -TPLX IS CONFIGURED WITH MOUNTING HOLES ON THE LID.

Triplexer Port	Triplexer Specifications	Comments
DC Port	9V typical, 16V maximum, <1A	For higher frequency modules, a 15V power supply may be needed to maintain typical module performance
LO Port	4-20 GHz	
IF Port	DC-3 GHz	VNAX IF limits usable range to ~7 MHz to ~1 GHz

Notes:

- Not recommended above WR3.4. Typical current draw of Rx module will exceed DC current rating on Triplexer.
- 9V and 15V Power Supply to be included with every Rx module with -TPLX option.
- Can be configured with the -5M and -SE options
- High insertion loss through user cable (for combined LO/IF/DC signals) may impact performance.



-RXX Module (Dual Rx)

The RXX (Dual Rx) Module integrates two standard Rx chains into one enclosure. The center-to-center spacing between the RF input waveguide test ports is 1.375 inches. Each Rx chain meets the standard specifications for Rx modules.

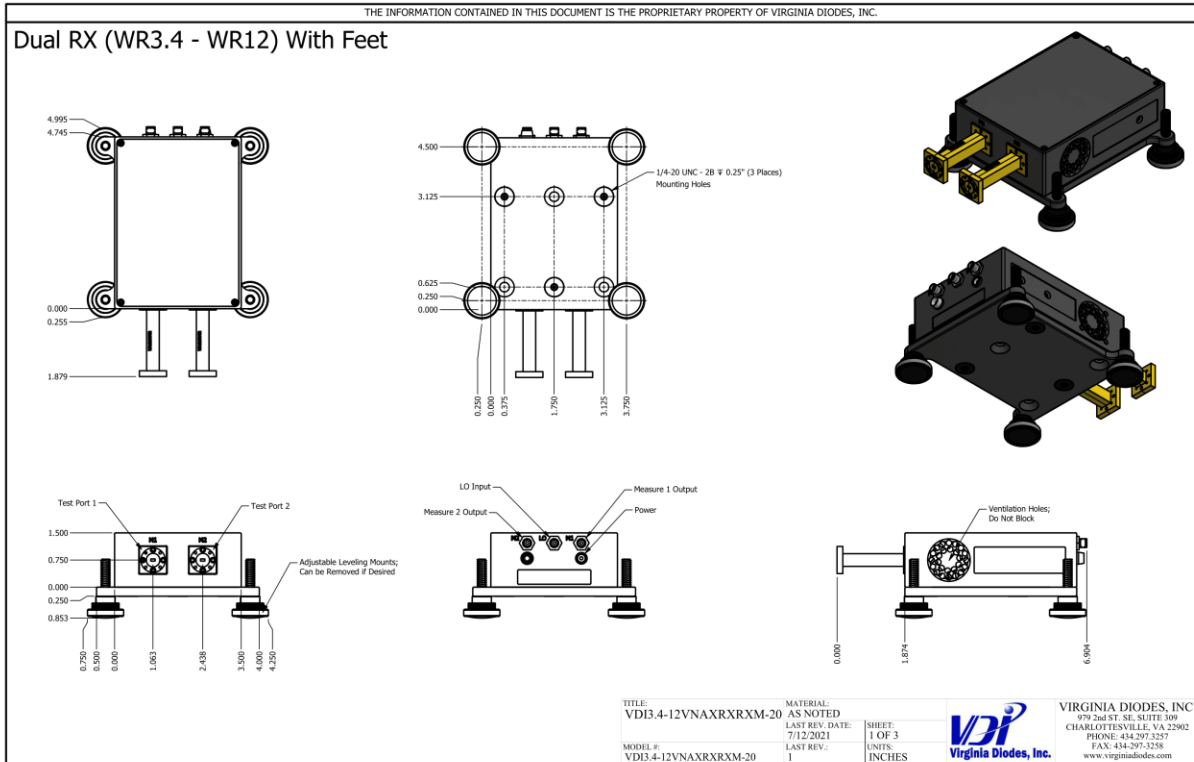

Notes:

- Can be configured with -5M and -SE options.



Available Configurations and Options

Part Number	-40	-5M	-A	-DS	-DS3	-P	-SE	-EB	-VVA	-HP	-MS	-M2
WR28VNAXTXRXM		✓										
WR22VNAXTXRXM		✓										
WR19VNAXTXRXM		✓										✓
WR15VNAXTXRXM	✓	✓	✓	✓	✓	✓	✓				✓	✓
WR12VNAXTXRXM	✓	✓	✓	✓	✓	✓	✓			✓	✓	✓
WR10VNAXTXRXM	✓	✓	✓	✓	✓	✓	✓		✓	✓	✓	✓
WR8.0VNAXTXRXM	✓	✓	✓	✓	✓					✓	✓	✓
WR6.5VNAXTXRXM	✓	✓	✓	✓	✓	✓			✓	✓	✓	✓
WR5.1VNAXTXRXM	✓	✓	✓	✓	✓			✓		✓	✓	
WR4.3VNAXTXRXM	✓	✓	✓	✓	✓					✓	✓	
WR3.4VNAXTXRXM	✓	✓	✓	✓	✓					✓	✓	
WM710(WR2.8)VNAXTXRXM	✓	✓	✓									
WM570(WR2.2)VNAXTXRXM	✓	✓	✓									
WM380(WR1.5)VNAXTXRXM	✓	✓	✓							✓		
WM250(WR1.0)VNAXTXRXM	✓	✓	✓									
WM164(WR0.65)VNAXTXRX		✓										

Same options apply for TxRef modules. For TxRef modules, replace **TxRx** with **TxRef** in the above part number.

Part Number	-5M	RXR	-TRPLX	-P	-SE
WR28VNAXRXM	✓	✓	✓		
WR22VNAXRXM	✓		✓		
WR19VNAXRXM	✓	✓	✓		
WR15VNAXRXM	✓	✓	✓	✓	✓
WR12VNAXRXM	✓	✓	✓	✓	✓
WR10VNAXRXM	✓	✓	✓	✓	✓
WR8.0VNAXRXM	✓	✓	✓		
WR6.5VNAXRXM	✓	✓	✓	✓	
WR5.1VNAXRXM	✓	✓	✓		
WR4.3VNAXRXM	✓	✓	✓		
WR3.4VNAXRXM	✓	✓	✓		
WM710(WR2.8)VNAXRXM	✓				
WM570(WR2.2)VNAXRXM	✓				
WM380(WR1.5)VNAXRXM	✓				
WM250(WR1.0)VNAXRXM	✓				
WM164(WR0.65)VNAXRX	✓				

Contact VDI for alternative configurations or options not listed above.



Product Overview and Accessories

VDI VNAX Modules utilize AC/DC power supplies/adapters, RF/LO/IF cables and software for VNA interface and operation. Equipment varies, as do RF/LO input limits (see labels). Contact VDI with RF/LO input limit or general operational questions before powering-up any module.

WR28 to WM250

RF/LO Drive Label

*Labeling on VNAX Modules shows the nominal RF/LO input for each product.
Must be used within damage limits*

Model No: VNAX	
S/N: VNAX 1723	
RF: N = 6	10 dBm
LO: N = 6	10 dBm
DC Input: 9V~4A	

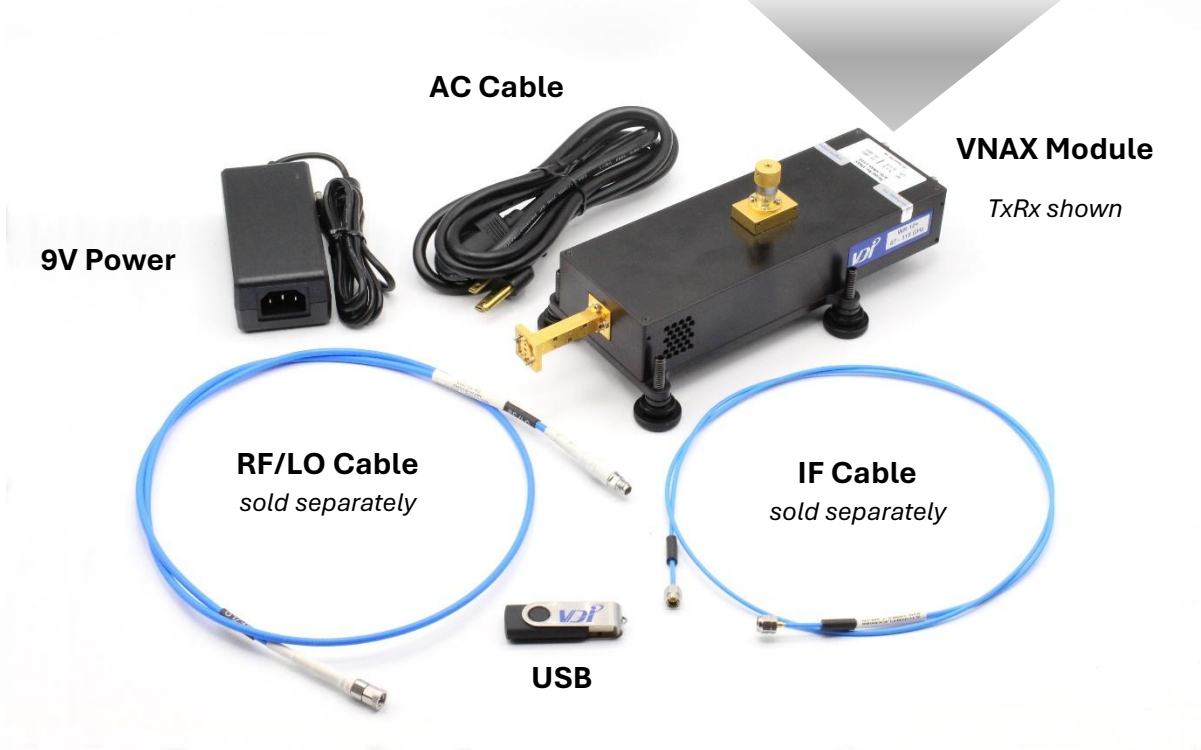

RF/LO Drive Label

Labeling on VNAX Modules shows the nominal RF/LO input for each product. Must be used within damage limits.

RF (L)	: N= 6	10 dBm
RF (H)	: N= 3	0 dBm
LO	: N= 6	10 dBm
		Virginia Diodes, Inc. www.vadiodes.com

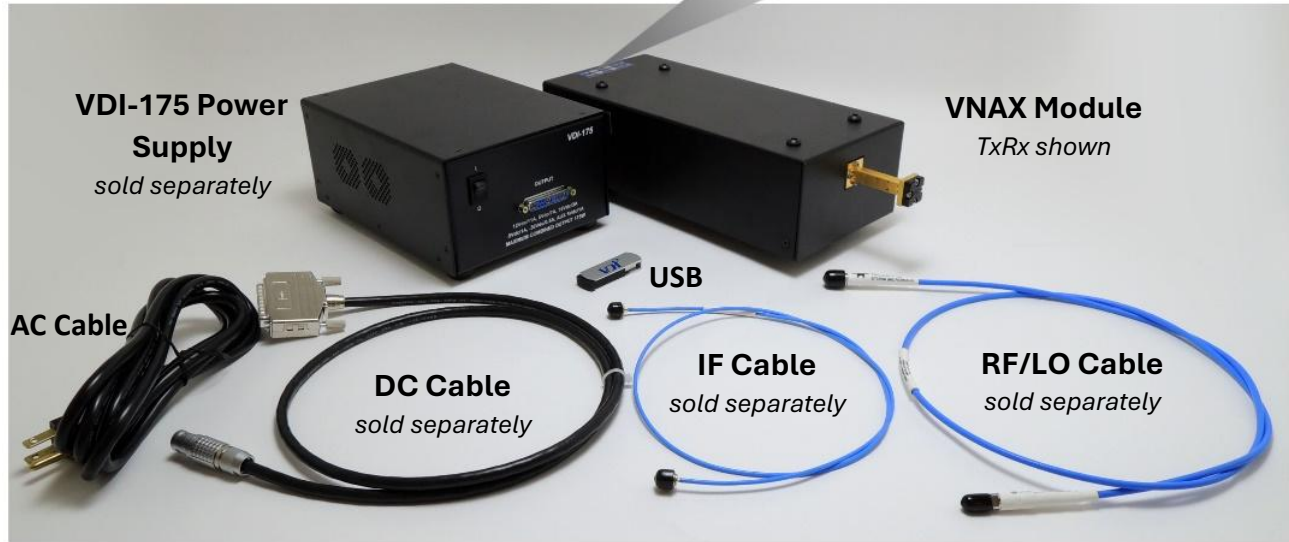

VNAX Module Ordering Notes

- VNA manufacturer and model number must be specified on PO. Purchasing VNAX Modules assume that the VNA is configured properly for frequency extension.
- Options can be purchased later, but the VNAX Module must be returned to VDI for modification.
- Cable Sets are sold separately (see Cable Set section for more information).
- For WM164, VDI-175 Power Supply + DC Cable is sold separately. For WR28 to WM250, the 9V Power Supply is included with the purchase of a VNAX Module.



WR-28 to WM-250 Module Details – Front and Rear Panel Connections



Front Panel

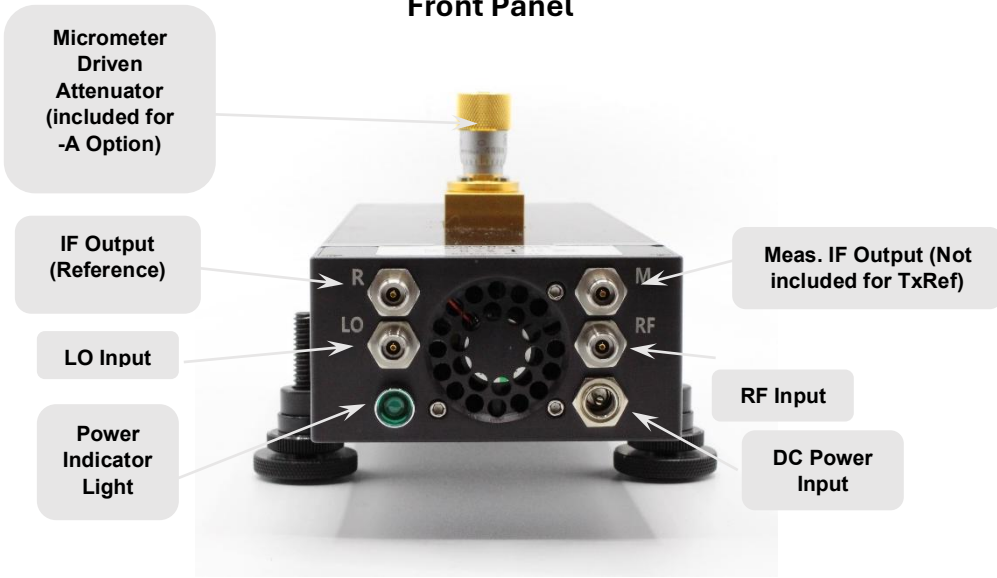

Rear Panel (TxRx, TxRef)



Rear Panel (Rx)



WM164 Module Details – Front and Rear Panel Connections

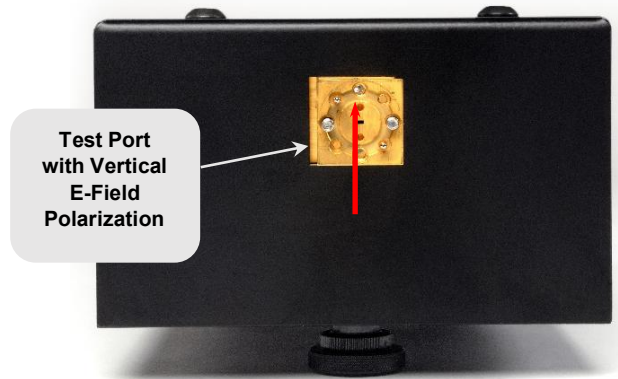

Front Panel

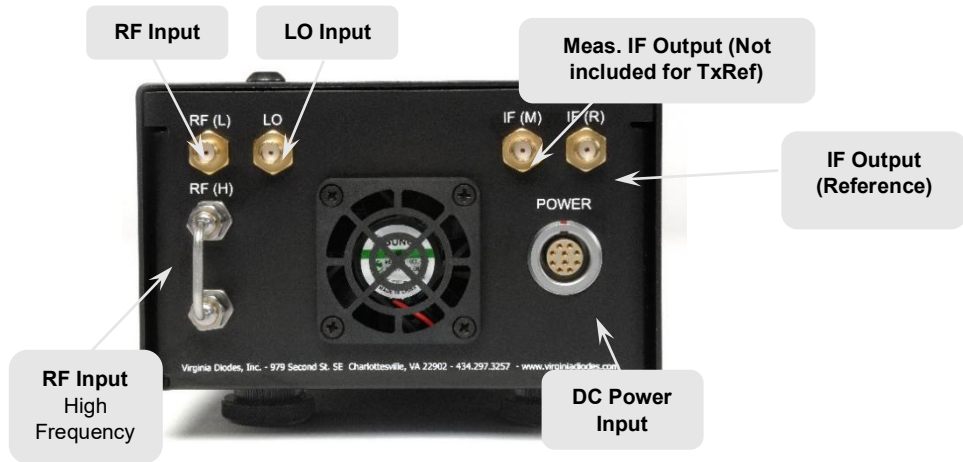

Rear Panel (TxRx, TxRef)



Rear Panel (Rx)



VNAX Performance – Dynamic Range and Test Port Power

Typical System Dynamic Range and Test Port Power plots for standard VNAX Modules are shown below, unless otherwise specified.

Standard System Performances

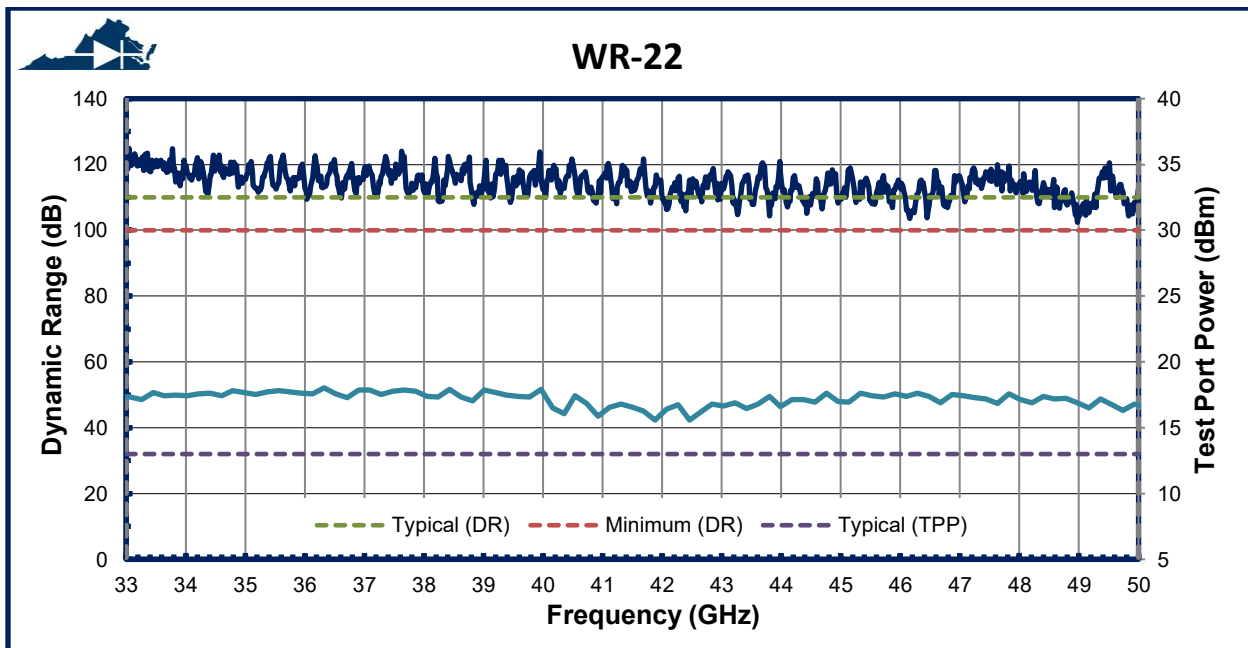
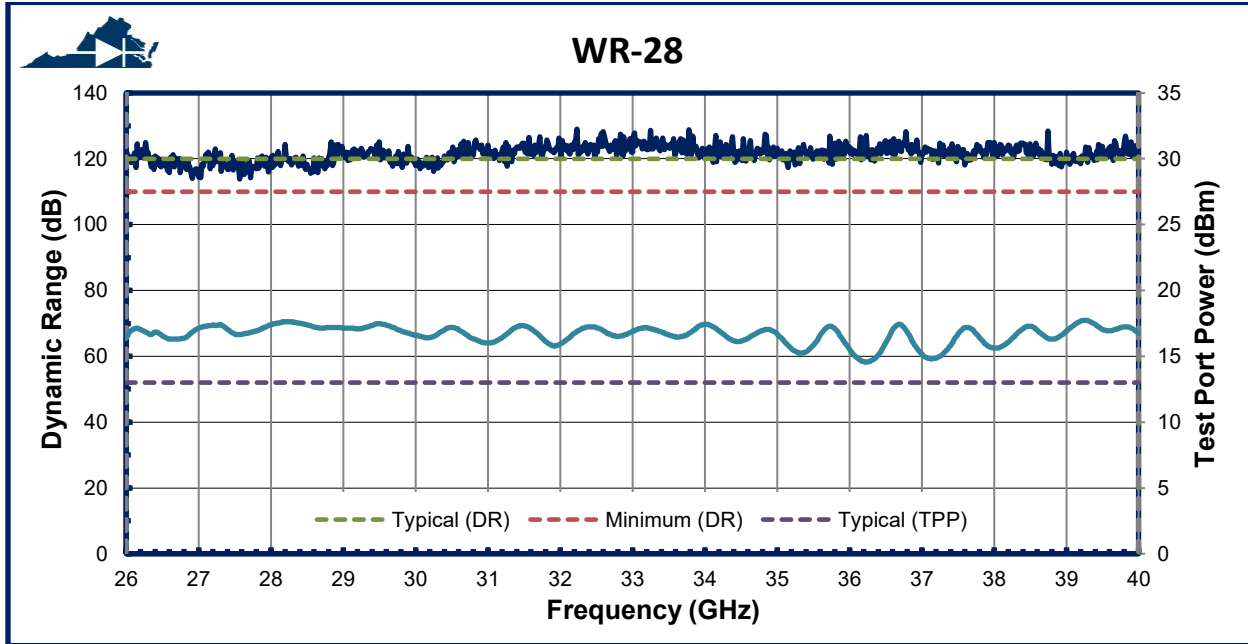

WR-19

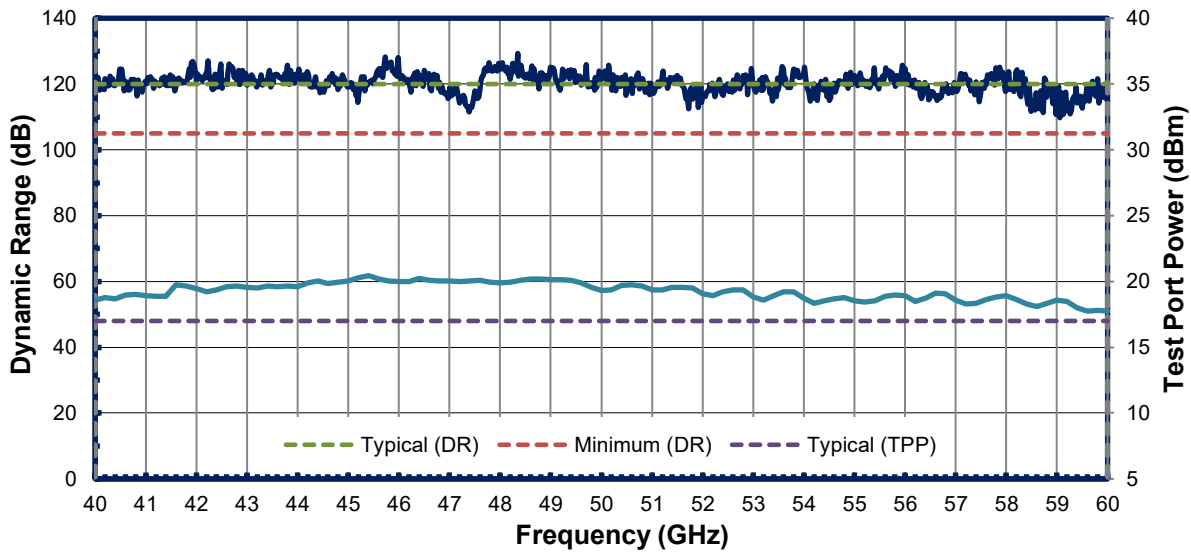

WR-15

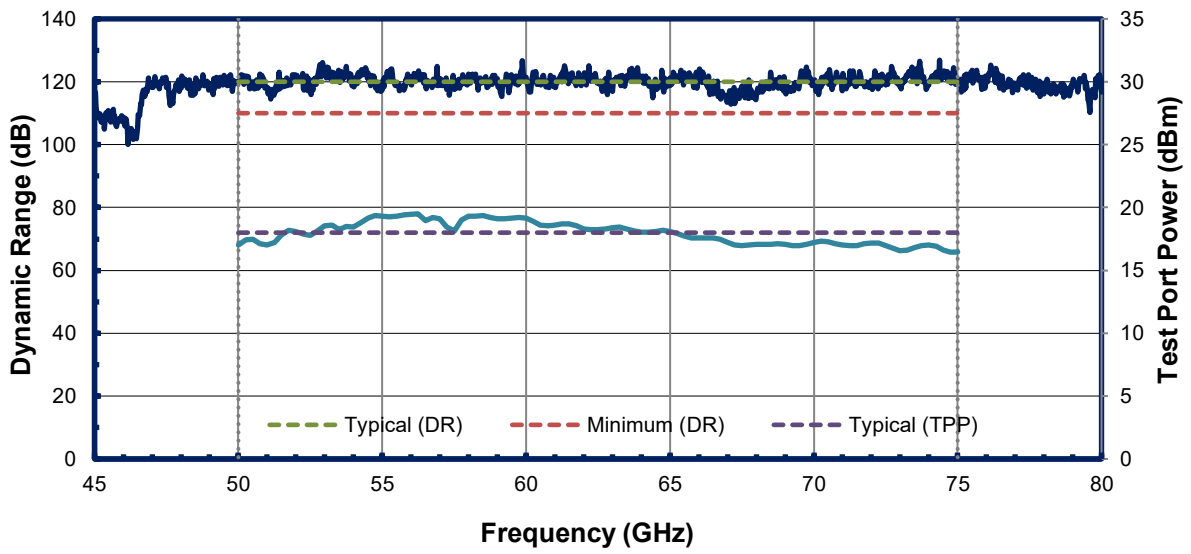

WR-12

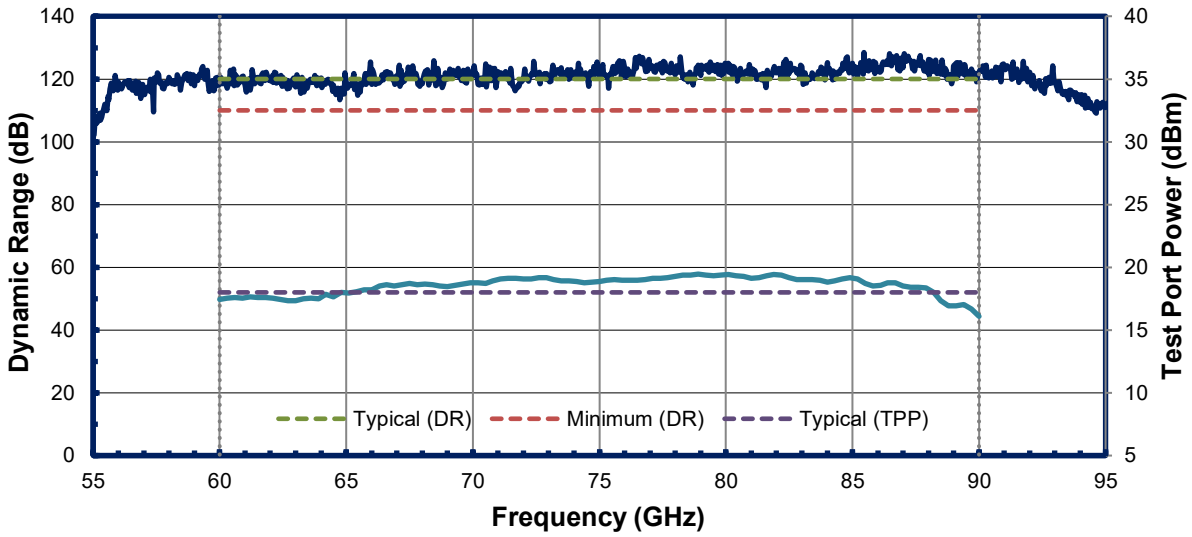

WR-10

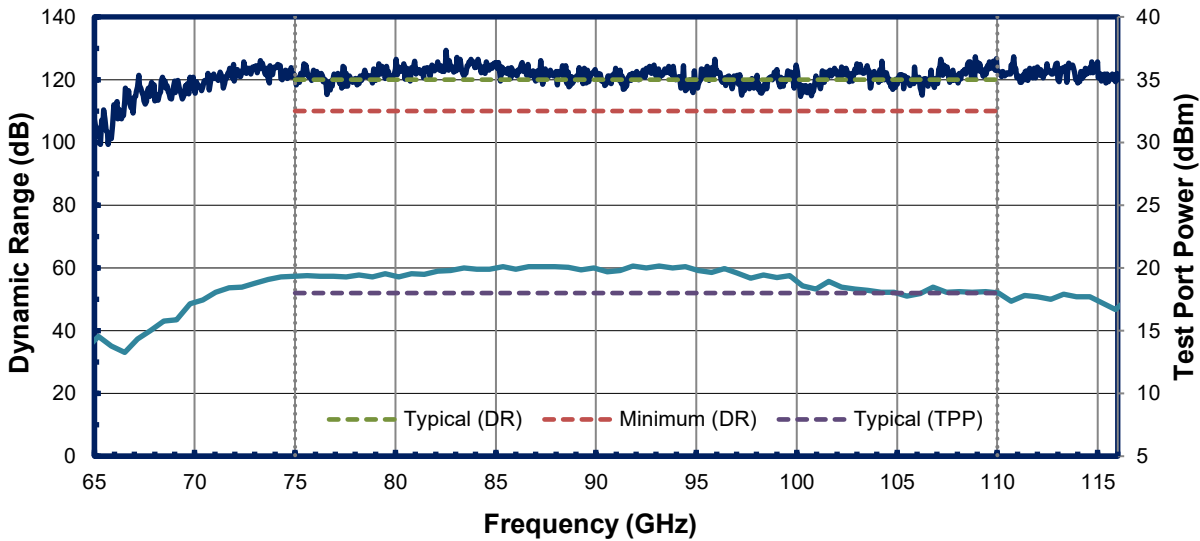

WR-8.0

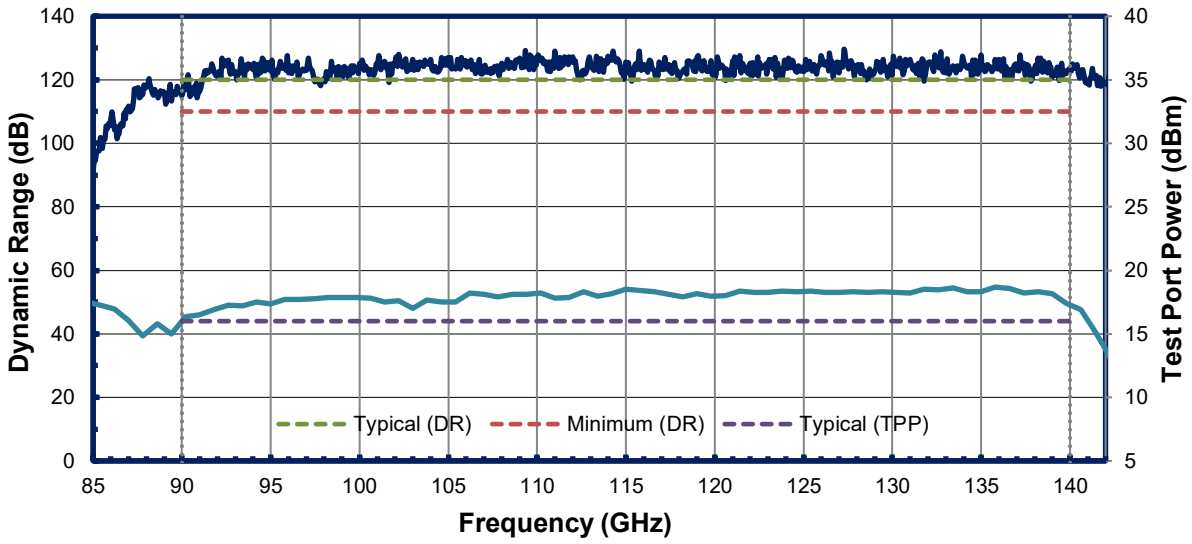

WR-6.5

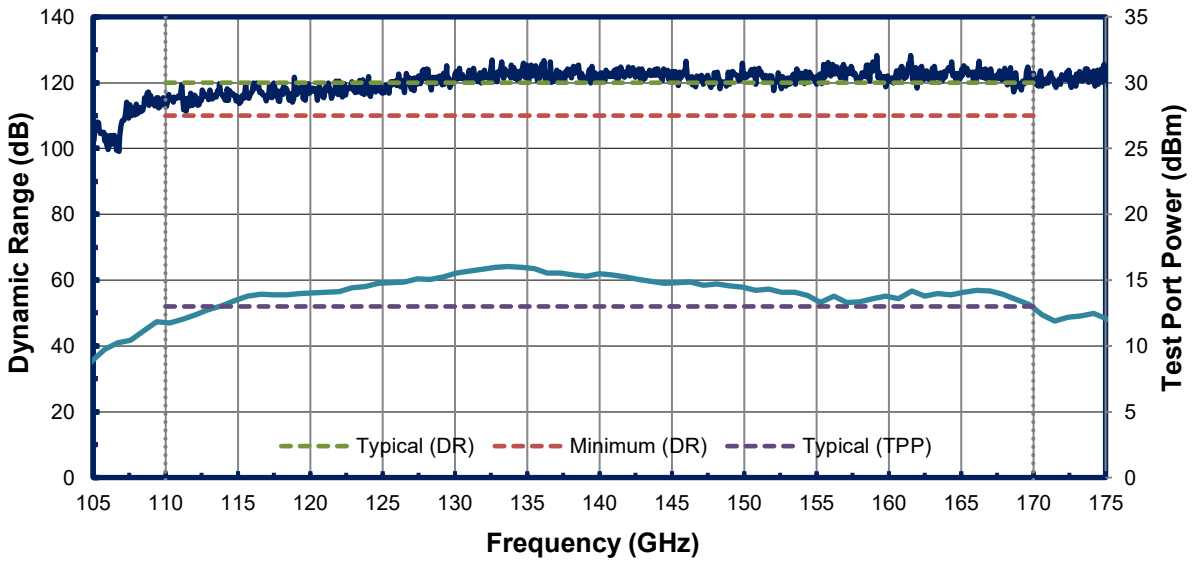

WR-5.1

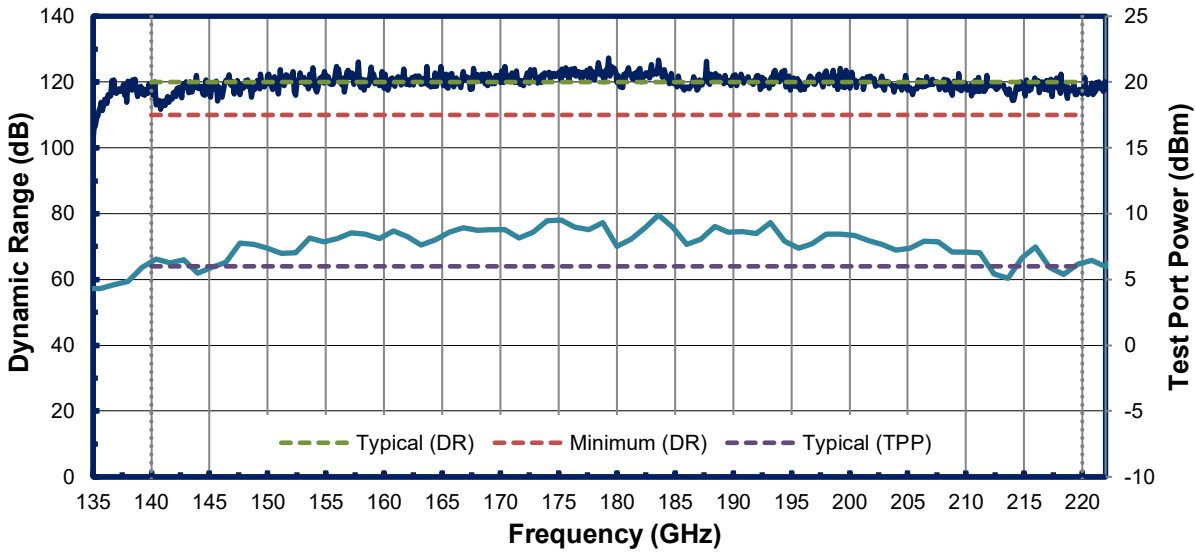

WR-4.3

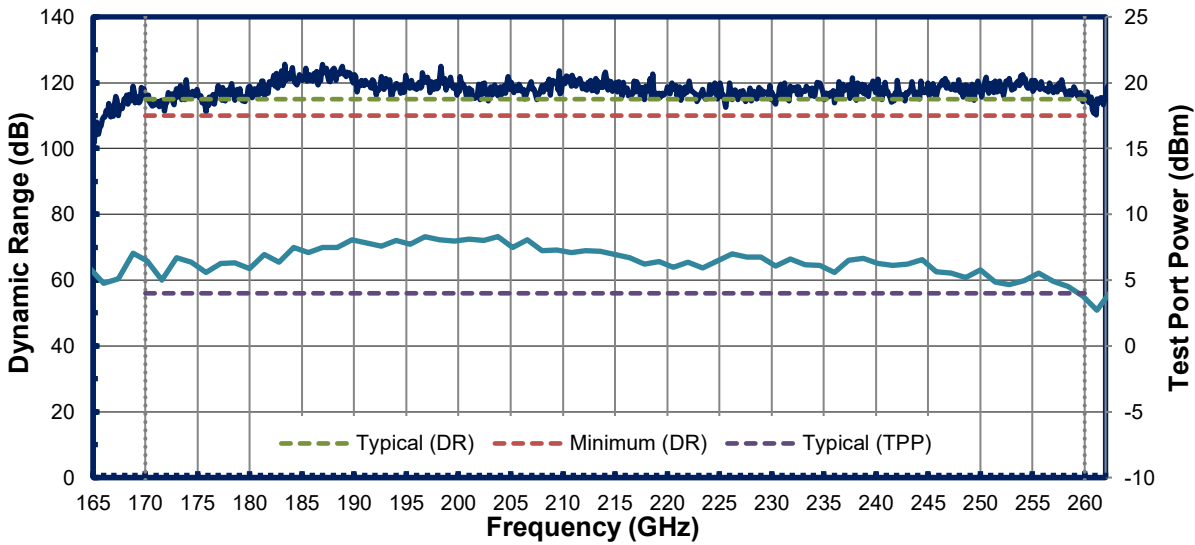

WR-3.4

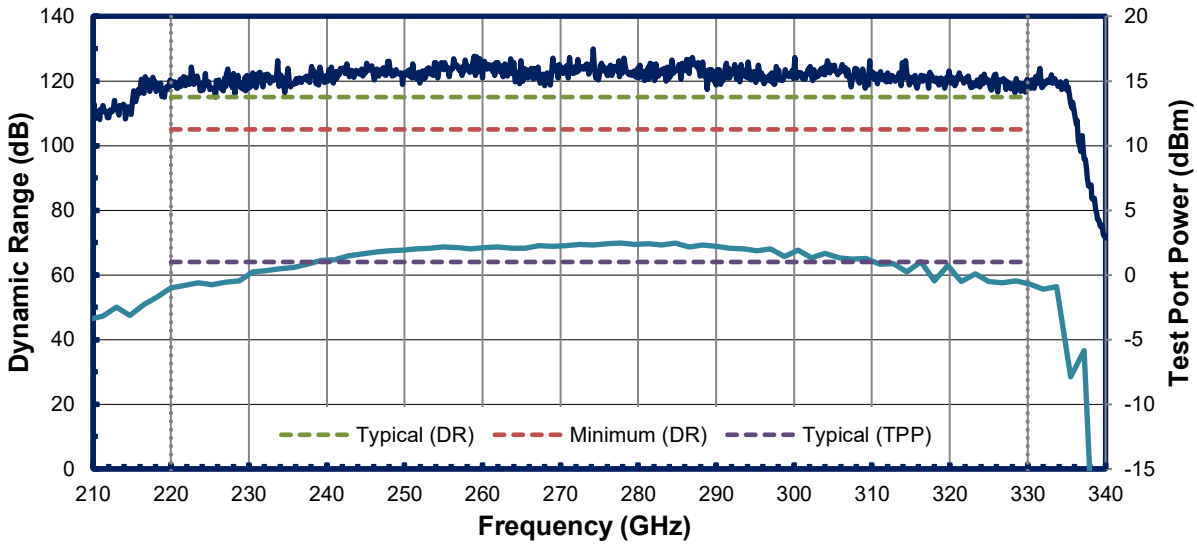

WM-710 (WR-2.8)

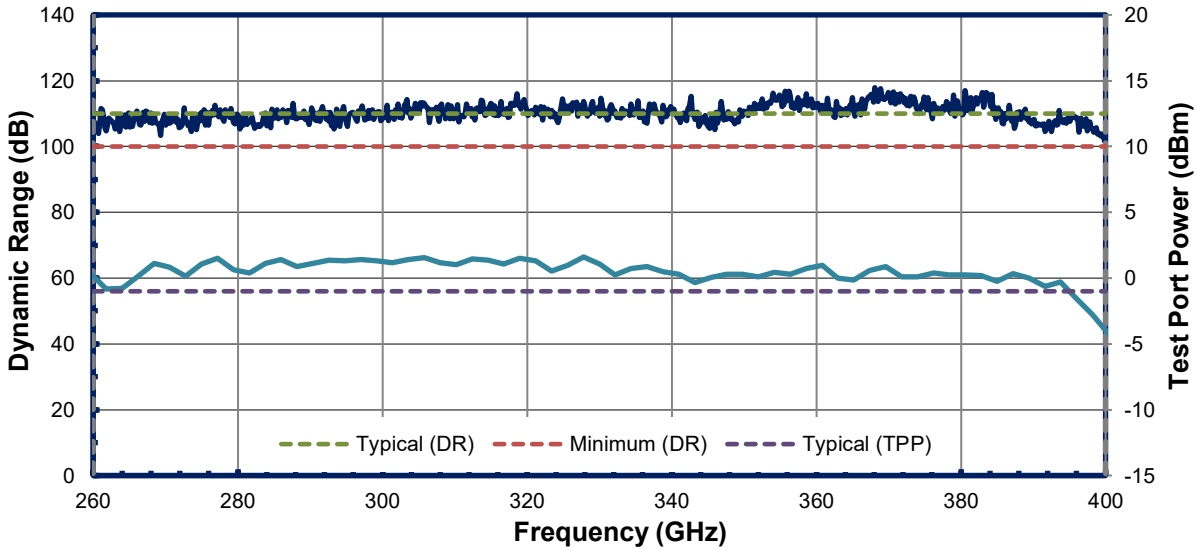

WM-570 (WR-2.2)

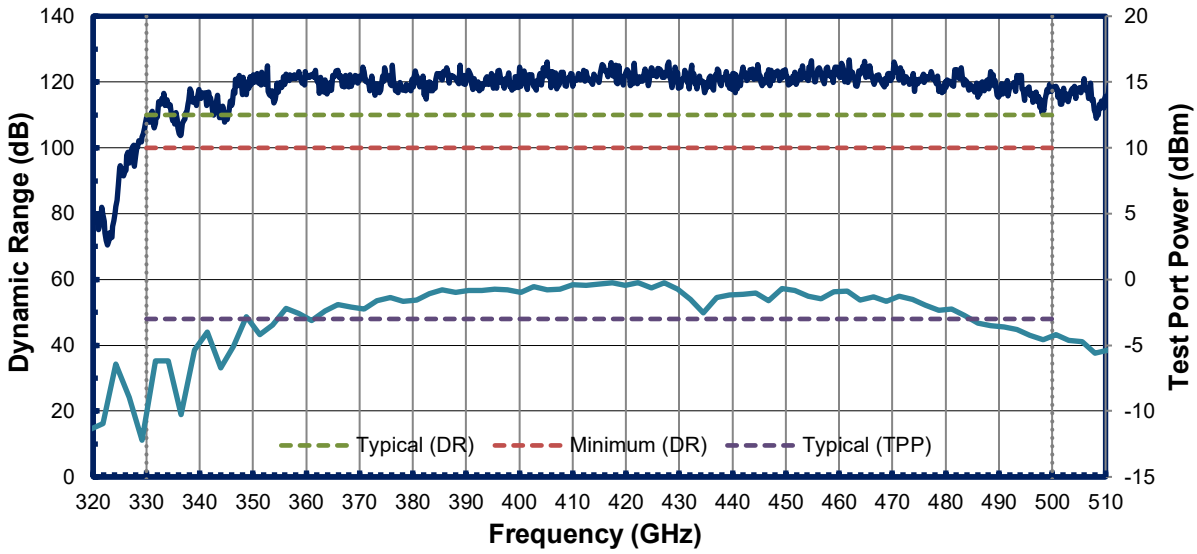

WM-380 (WR-1.5)

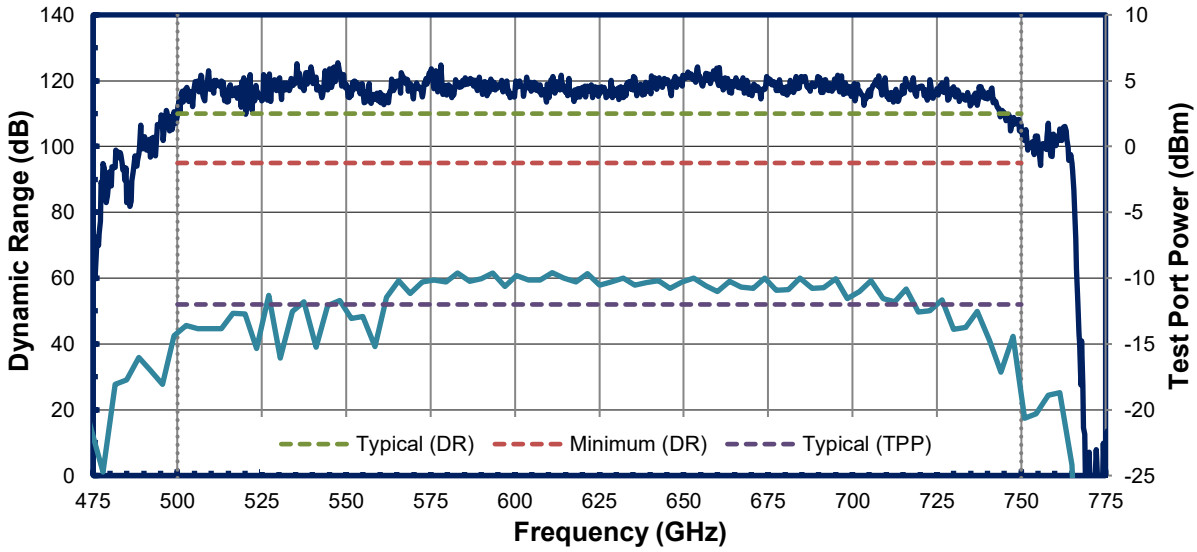



WM-250 (WR-1.0)

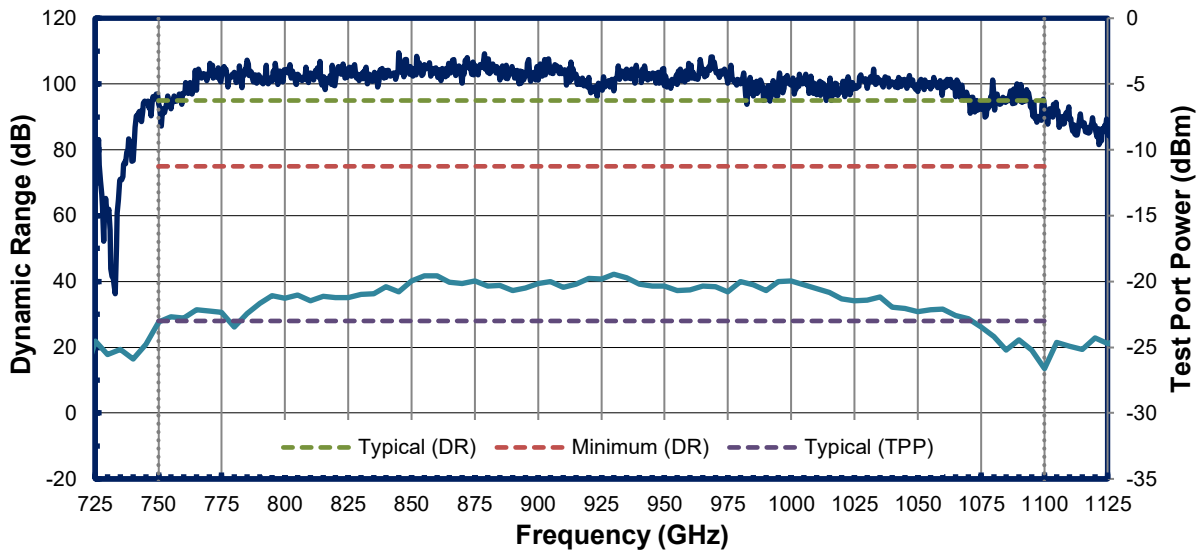

WM-164 (WR-0.65) - TxRx-Rx

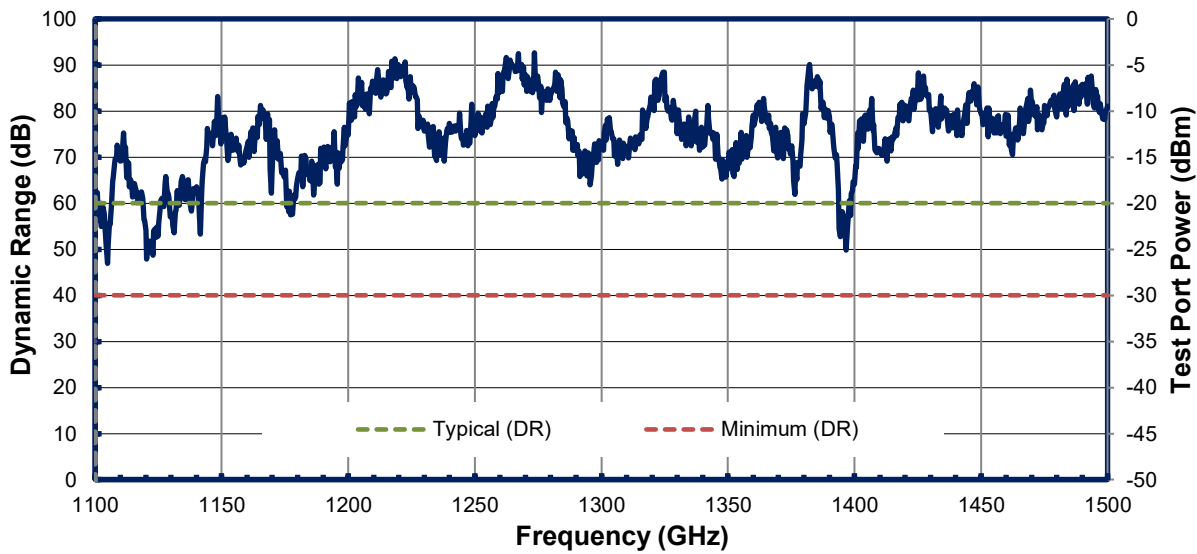

-SE Modules (Reduced Performance)

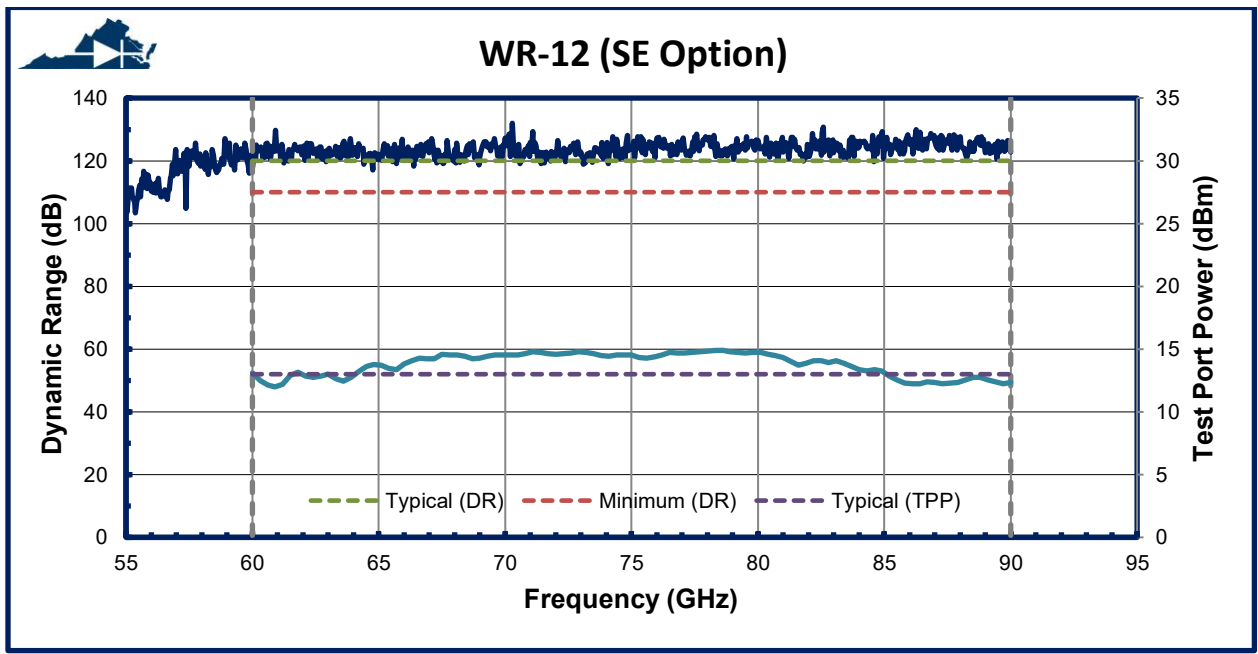
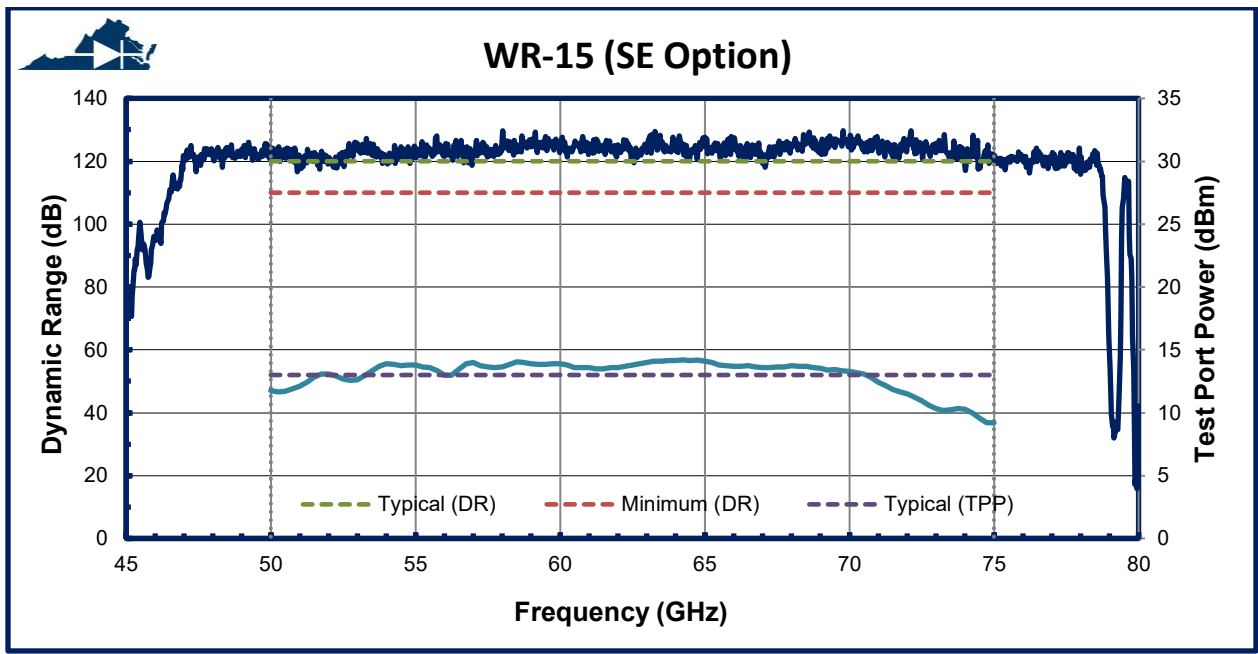

WR-10 (SE Option)

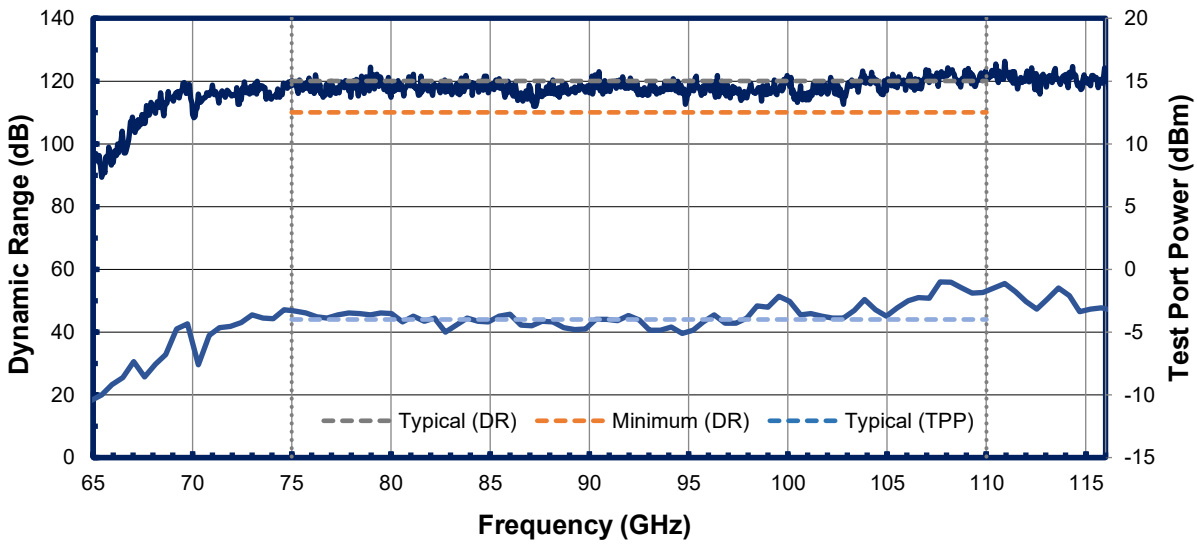

-DS and -DS3 Option (Dual Source)

WR-15 (DS Option)

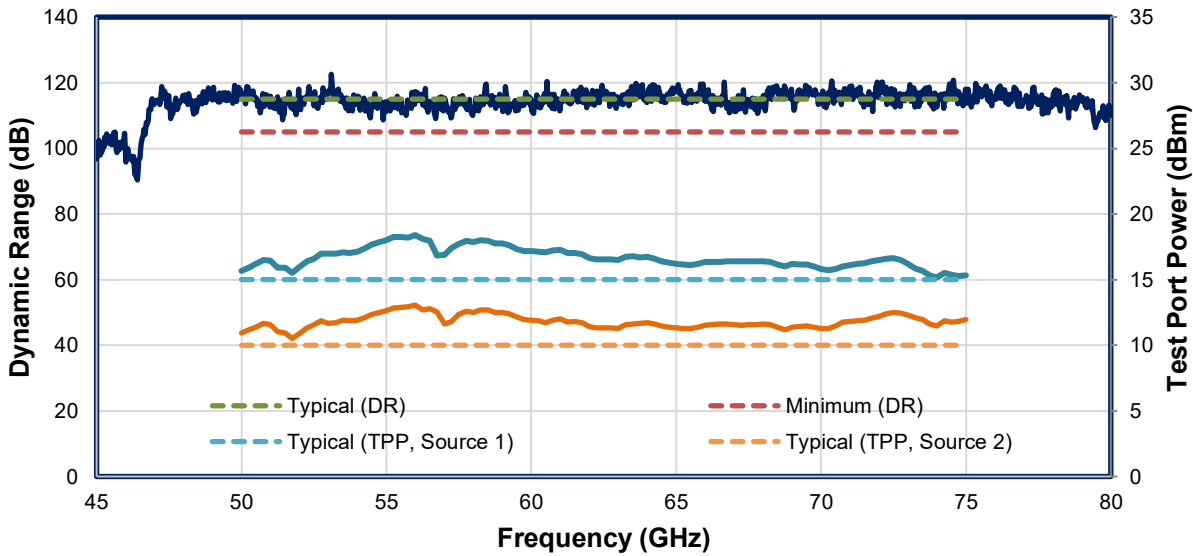

WR-15 (DS3 Option)

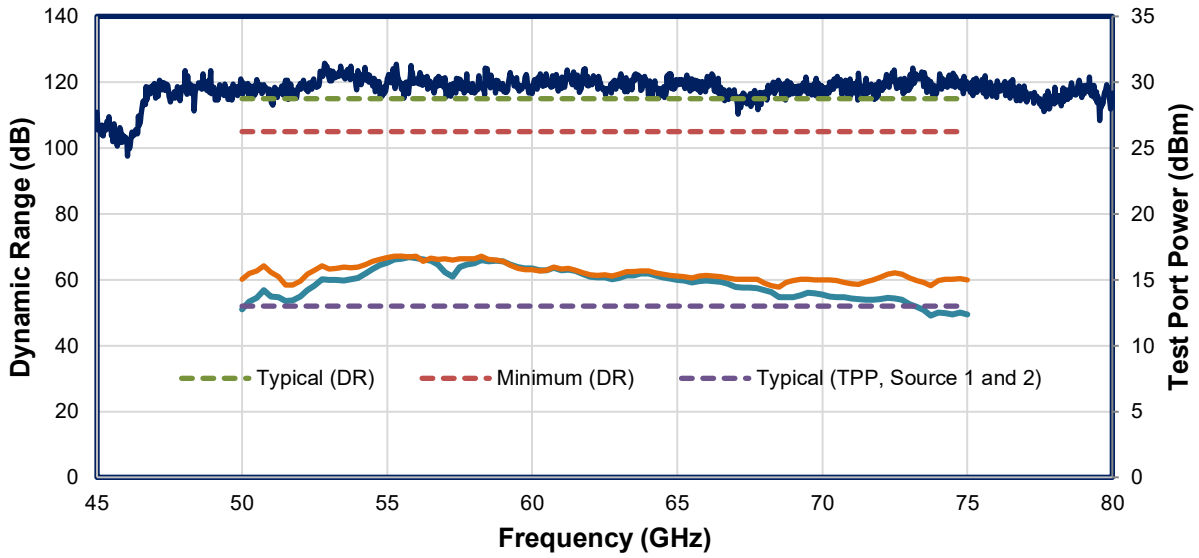

WR-12 (DS Option)

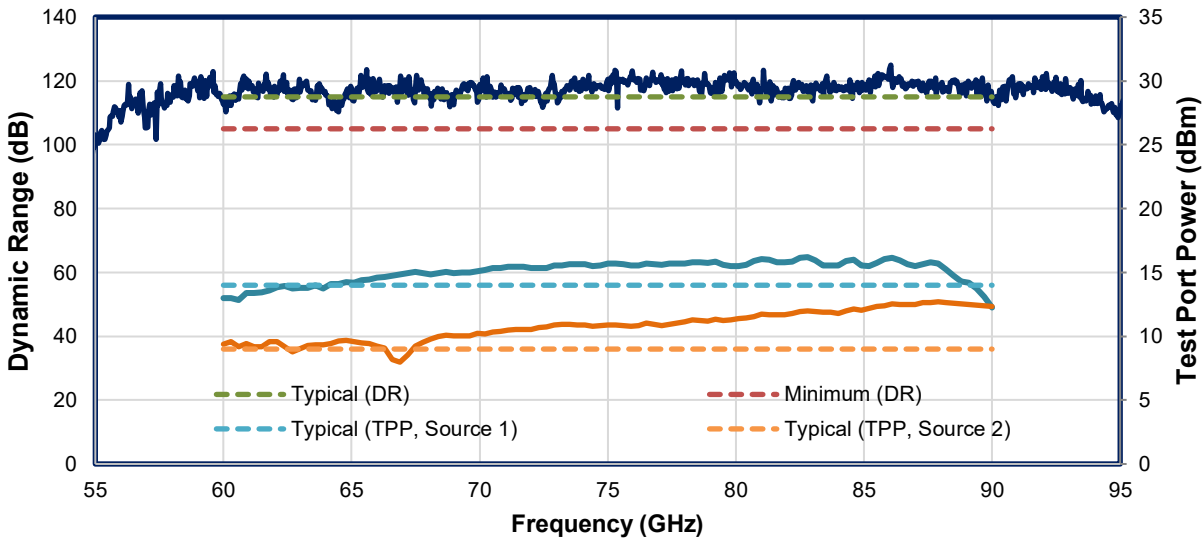

WR-12 (DS3 Option)

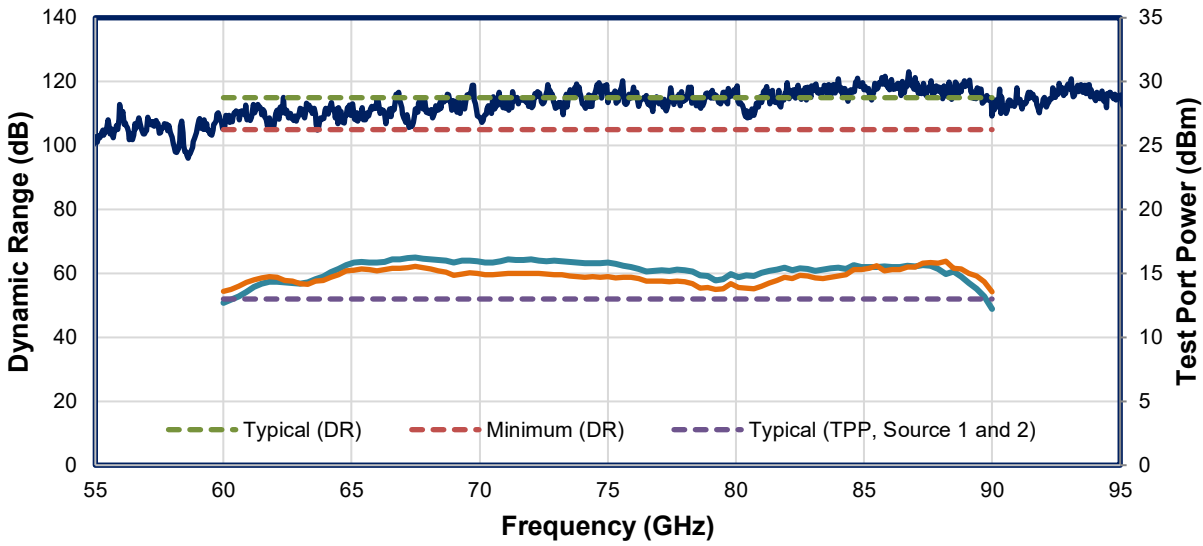

WR-10 (DS Option)

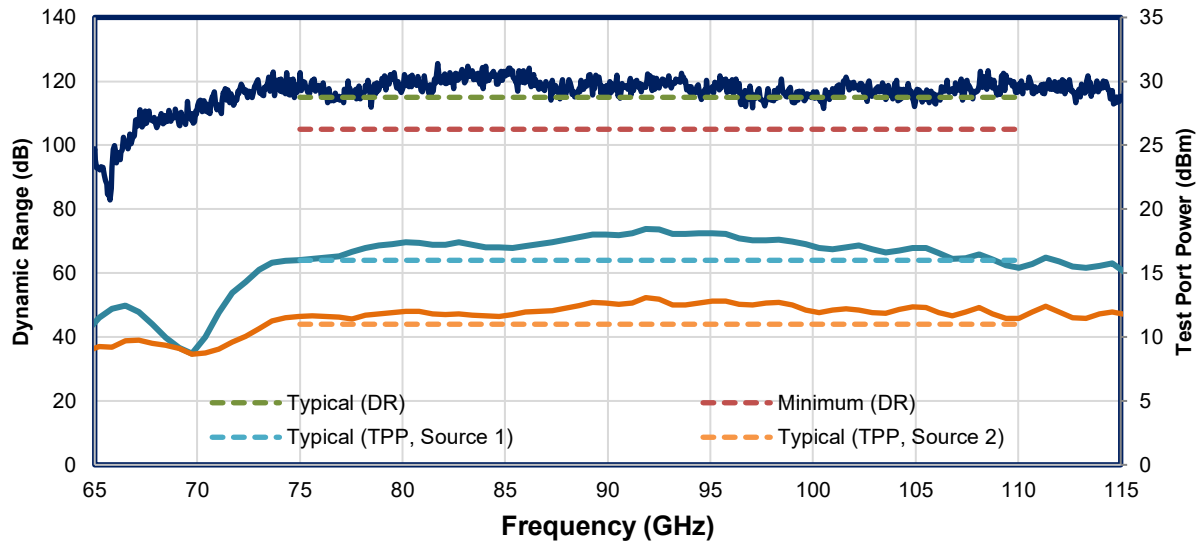

WR-10 (DS3 Option)

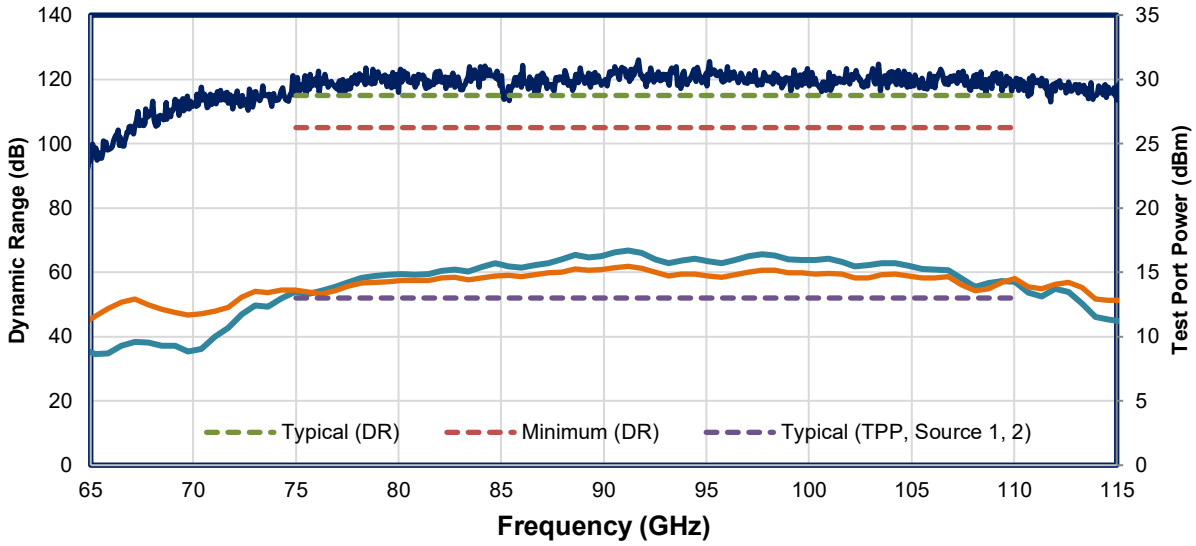

WR8.0VNAX (DS Option)

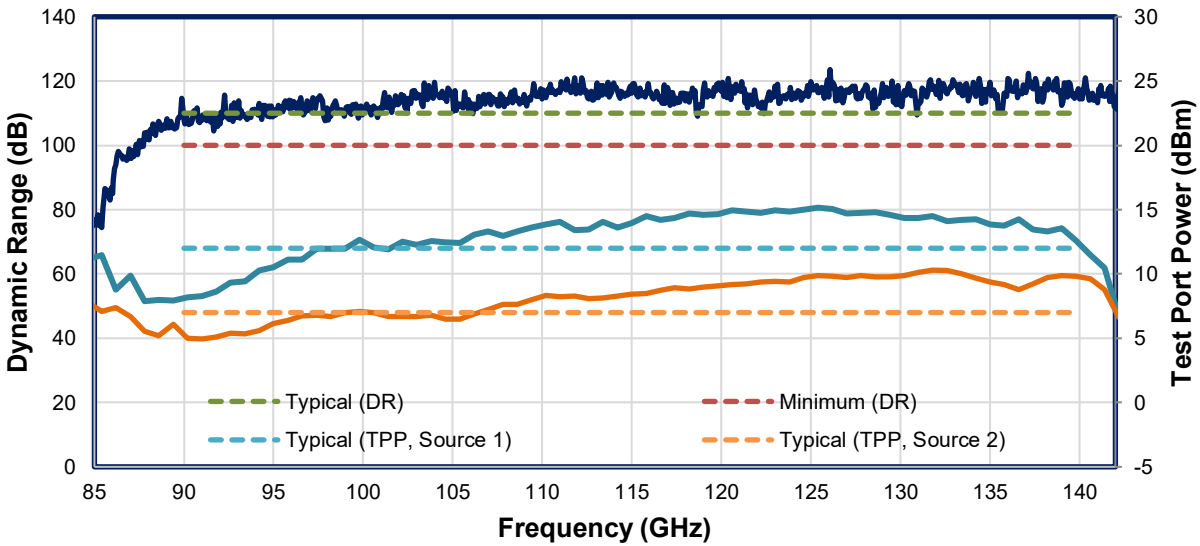

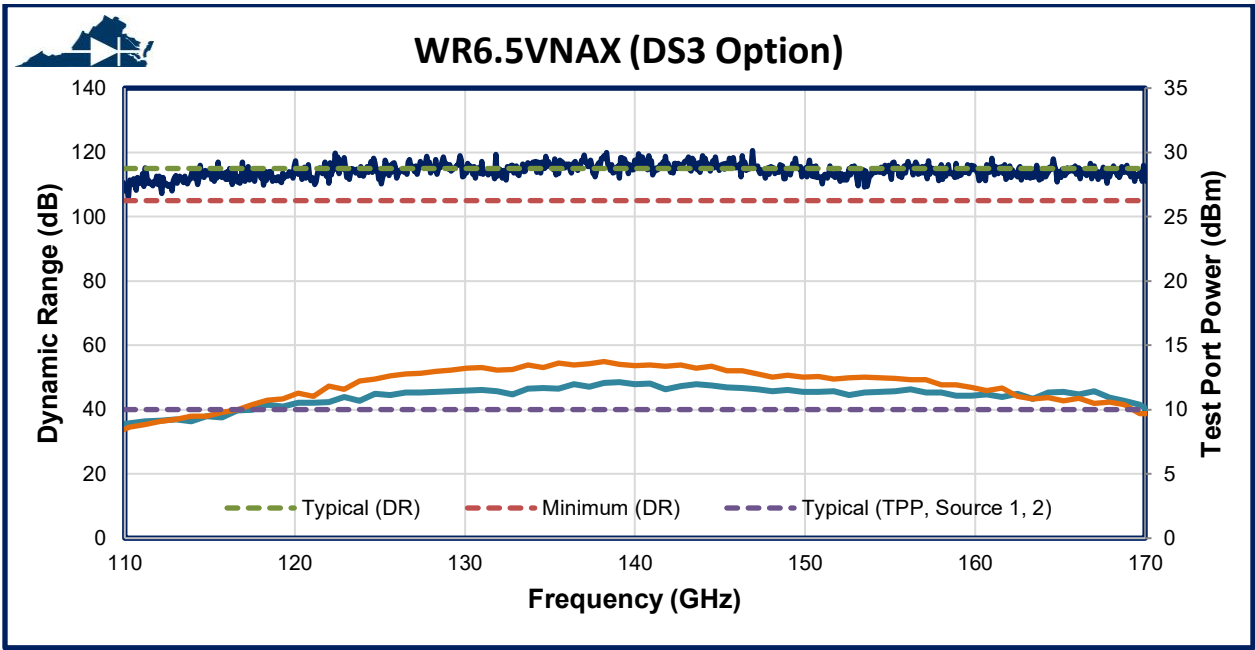

-MS Modules (VNAX with Mixed Signal Input)

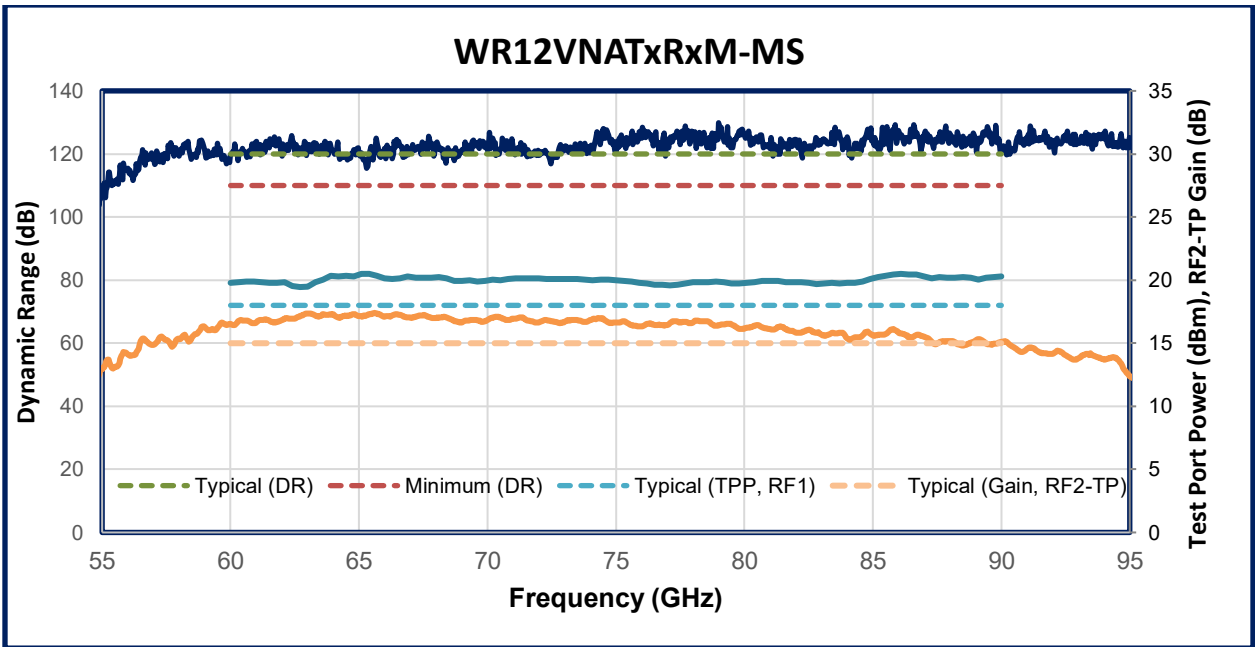

WR10VNATxRxM-MS

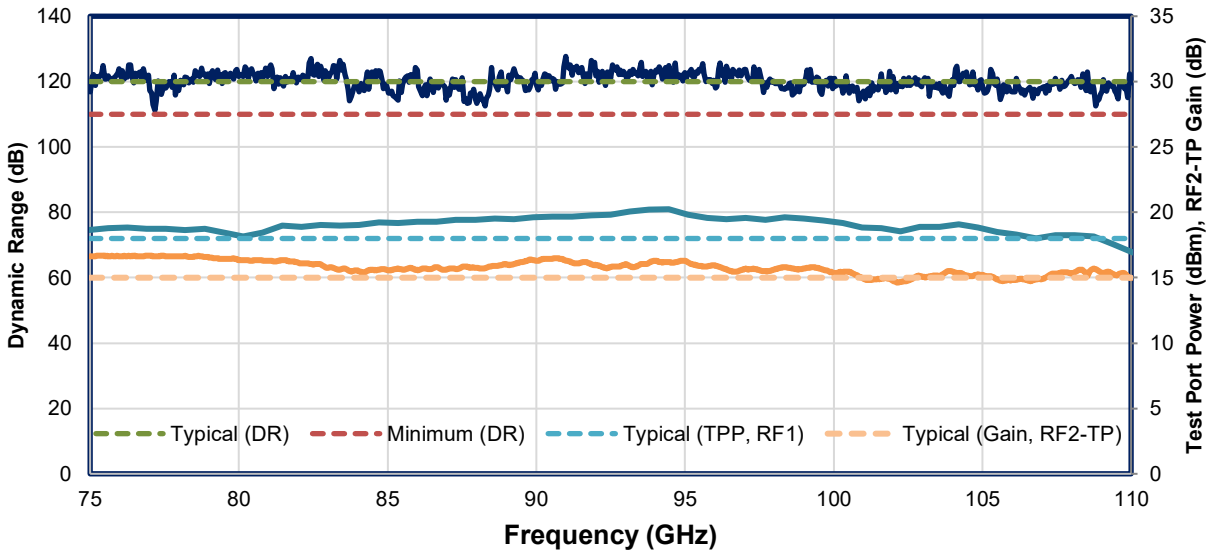

WR8.0VNATxRxM-MS

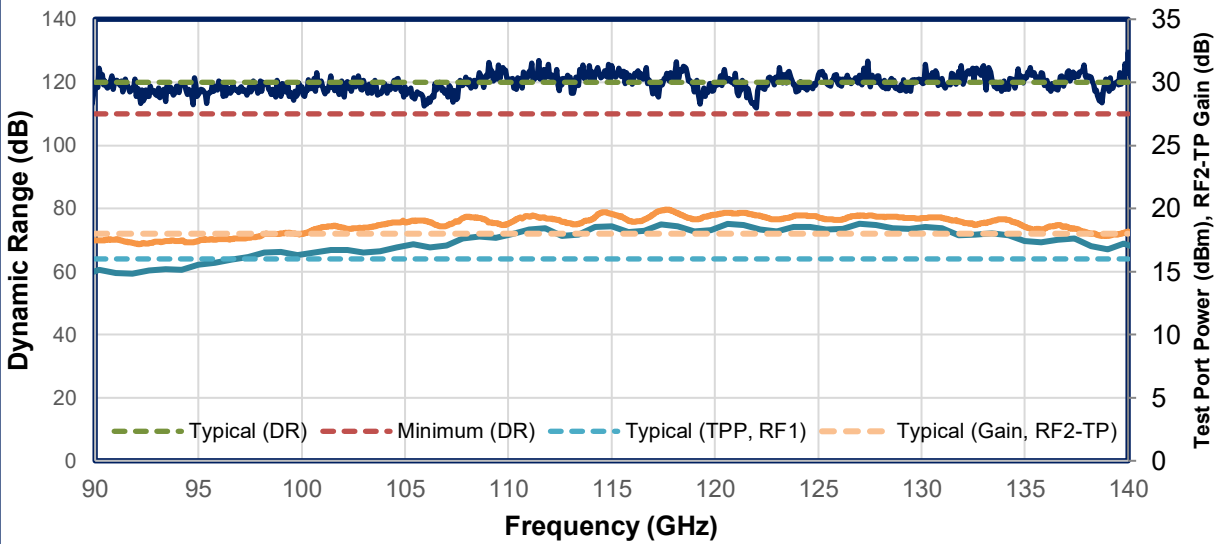

WR6.5VNATxRxM-MS

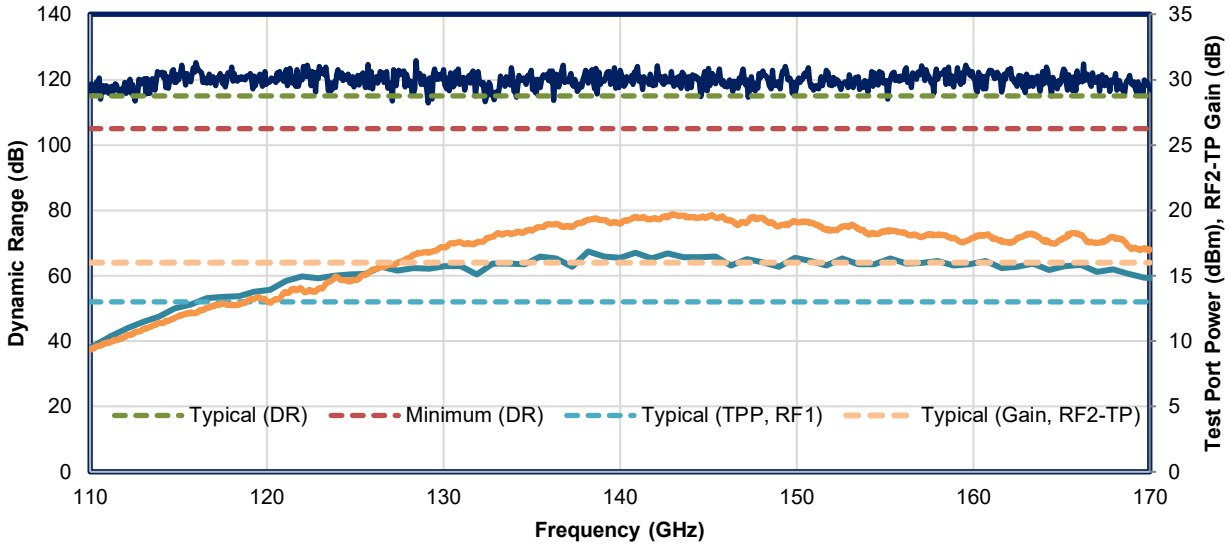

WR5.1VNATxRxM-MS

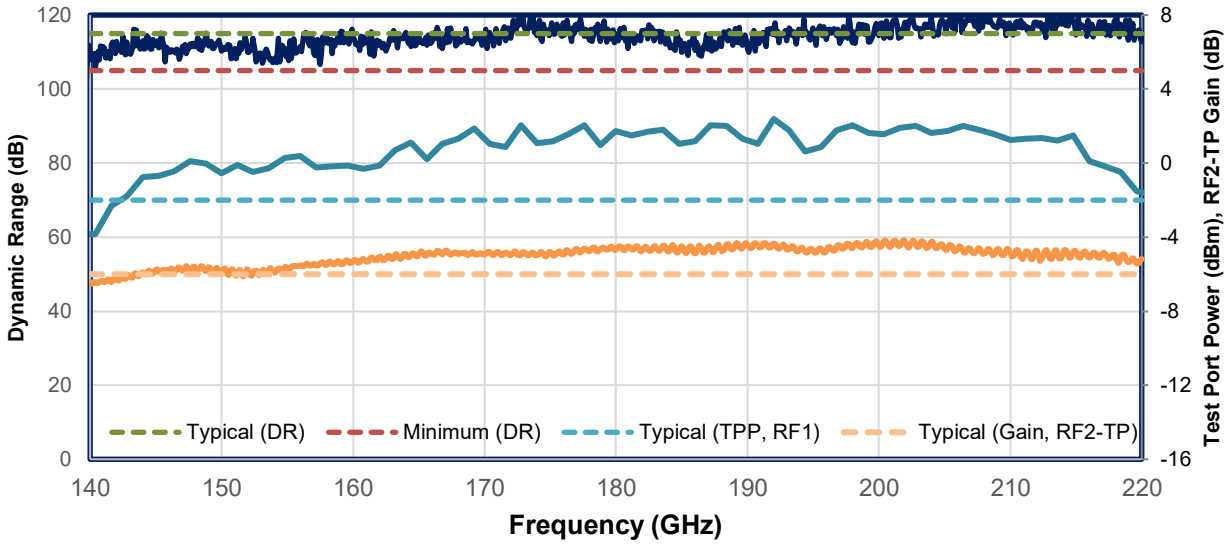

WR3.4VNATxRxM-MS

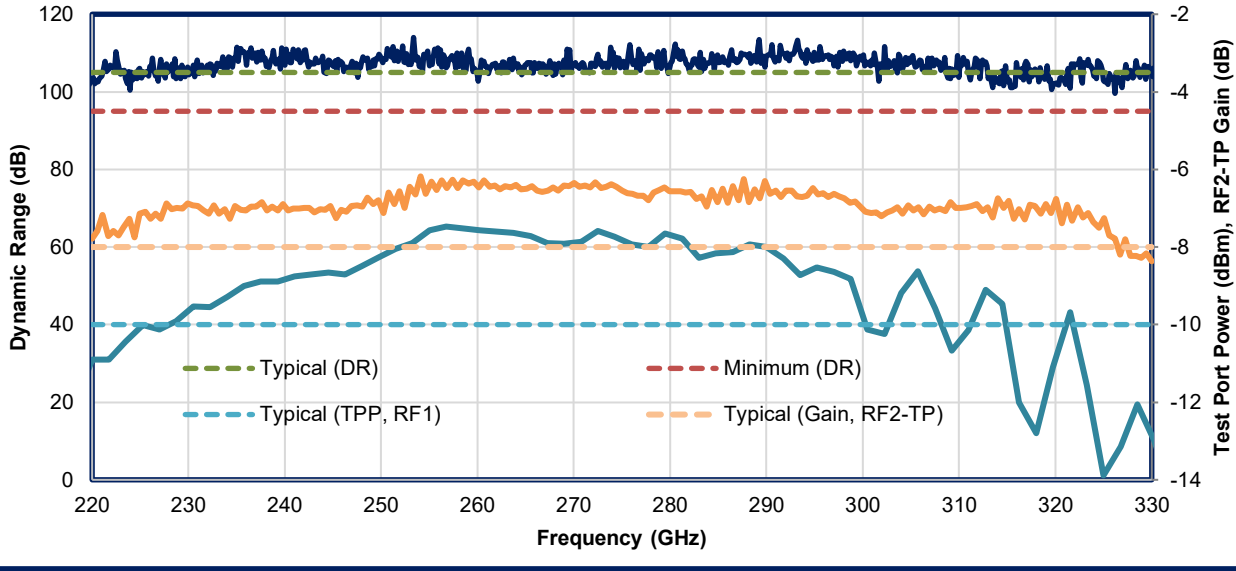

-HP Modules (High Power VNAX)

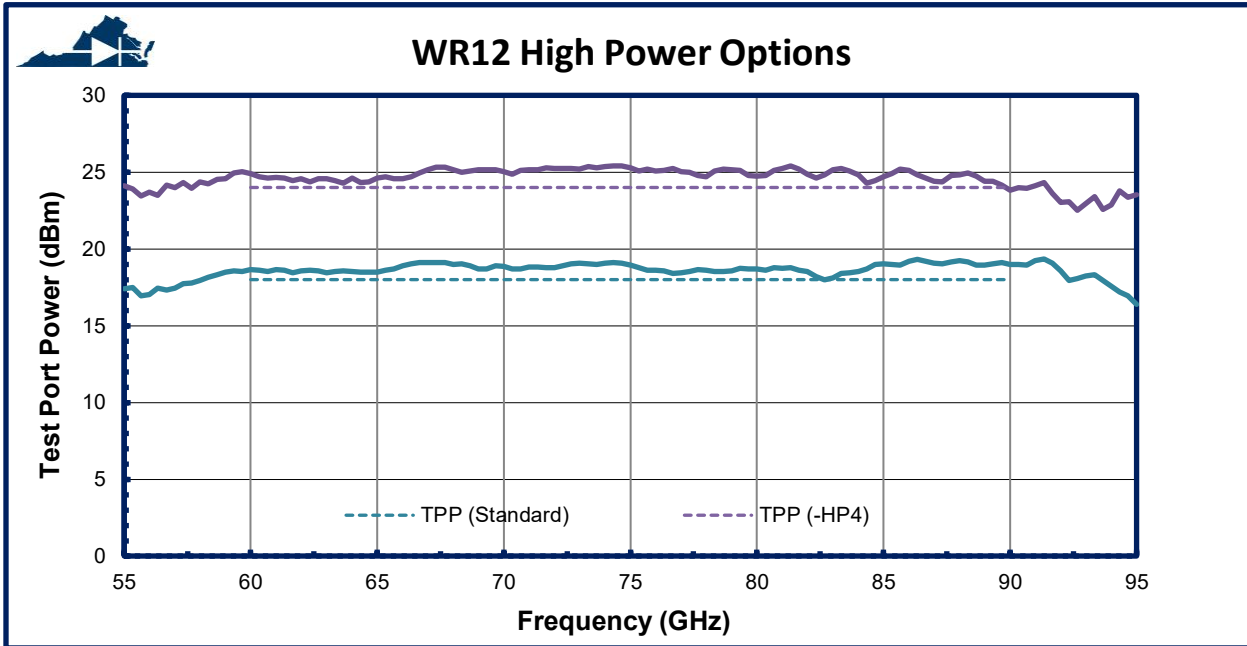



WR10.0 High Power Options

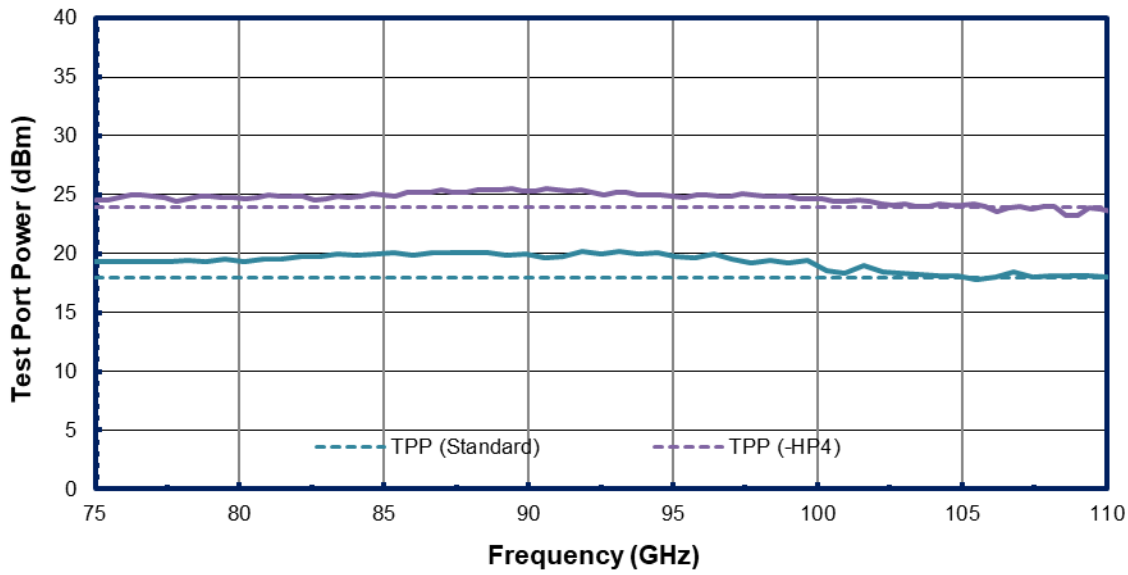

WR8.0 High Power Options

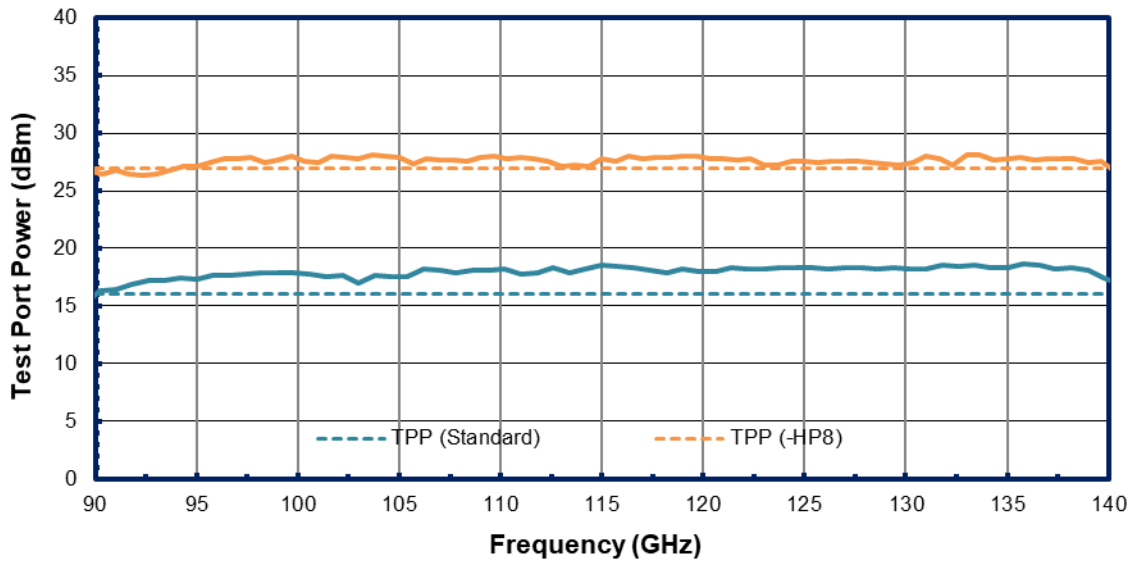



WR6.5 High Power Options

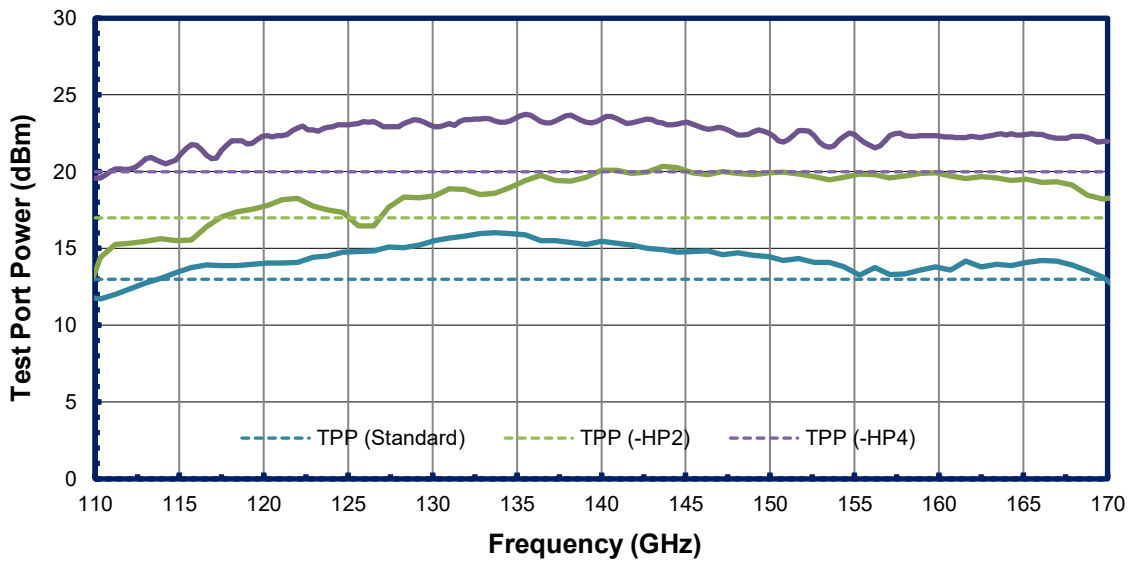

WR5.1 High Power Options

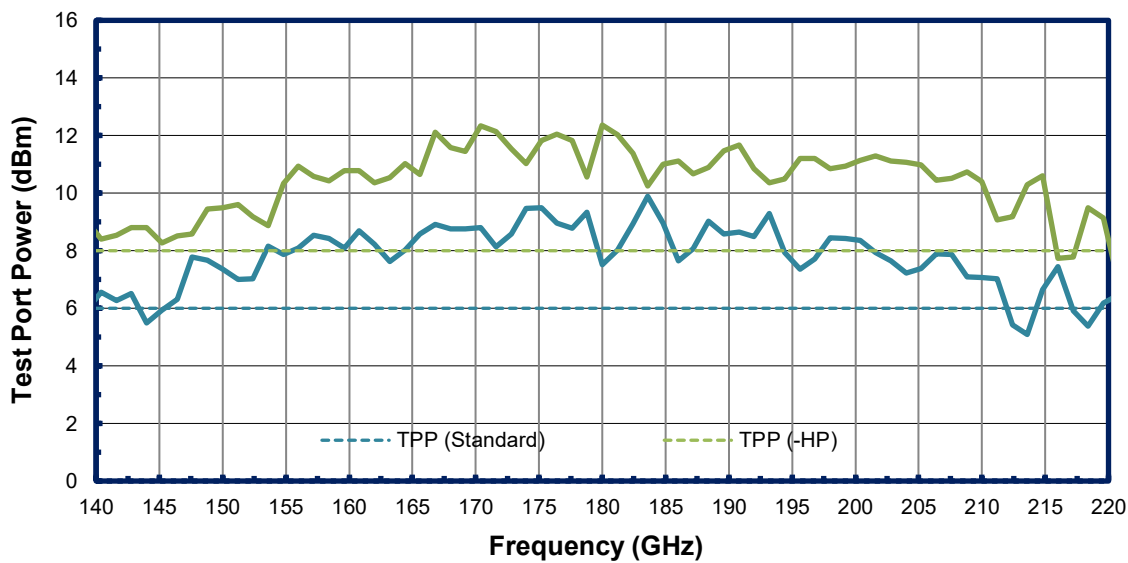



WR4.3 High Power Options

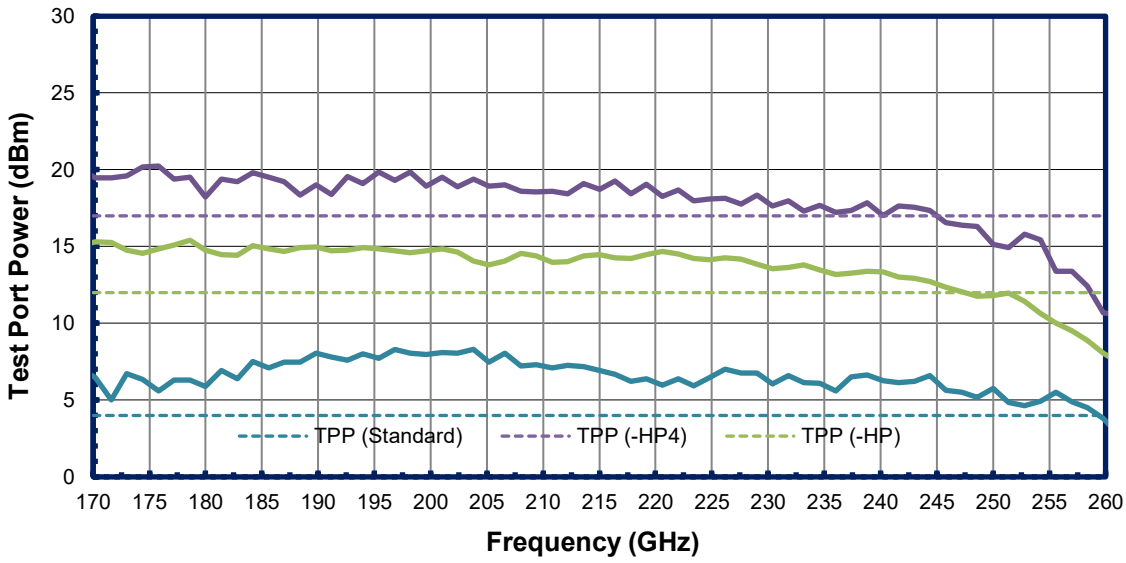

WR3.4 High Power Options

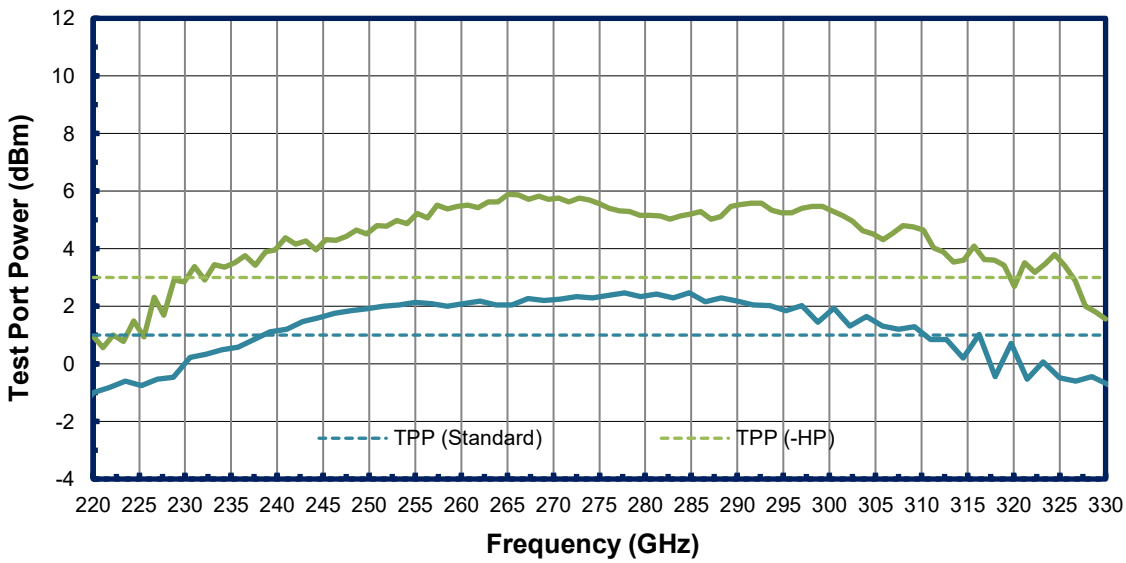



WM380 High Power Options

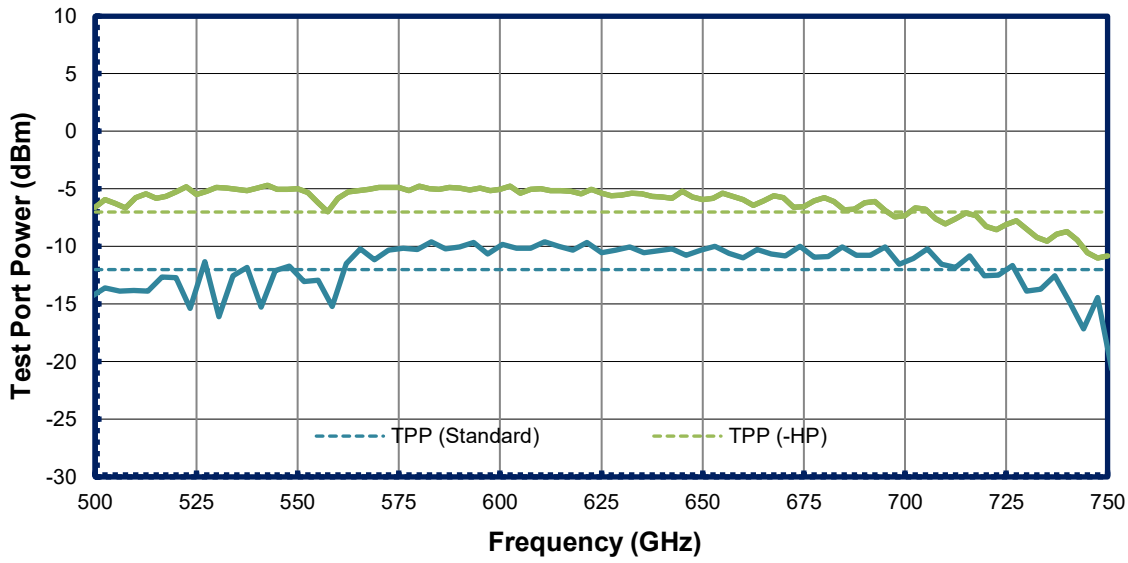

Calibration Kits





VDI offers banded waveguide calibration kits for s-parameter calibration of our extension modules. Two different calibration techniques are offered: TRL (Through-Reflect-Line) calibrations for WR-19 through WR-3.4; SOLT (Short-Open-Load-Through) calibrations for WM-710 through WM-250. These standard versions are described here. For more VNA calibration theory information, please refer to Keysight’s application note AN1287-3: “[Network Analysis Basics - Applying Error Correction To Network Analyzer Measurements](#).” For instructions to set up calibration kit definitions, refer to application note: “[Specifying Calibration Standards and Kits for Keysight Vector Network Analyzers](#).” Please contact VDI with any other questions regarding calibration procedures.

Electronic calibration kit definitions compatible with Keysight Network Analyzers are included with the calibration kits and can be downloaded from the VDI website (<https://vadiodes.com/en/resources/downloads>).

Type A vs. Type B Calibration Kits

There are two versions of the delay calibration standards (QW’s and QD’s) available in Type A (legacy) and Type B (current). Type A calibration kit definitions are available for download on the VDI website.

Care should be taken to identify your calibration kit version before downloading the electronic calibration kit definitions or using the delay lengths and other equipment supplied with your kit. Identification can easily be achieved by examining the shape of the QW and QD calibration standards.

Type A Standard (Legacy)	Type B Standard (Current)
 QW (Quarter Wave Delay Shim)	 QW (Quarter Wave Delay Shim)
 QD (Quarter Wave Delay Short)	 QD (Quarter Wave Delay Short)

Calibration Kit Component Care and Handling

Please remember that reasonable care must be used when handling the waveguide and shim components of each Calibration Kit. Contact VDI with questions or concerns.

Waveguide Clamp

Waveguide clamps are not included in the calibration kits but may reduce testing time. Please see Waveguide Clamp section at the end of this document for more information.



SOLT and TRL Calibration Kits

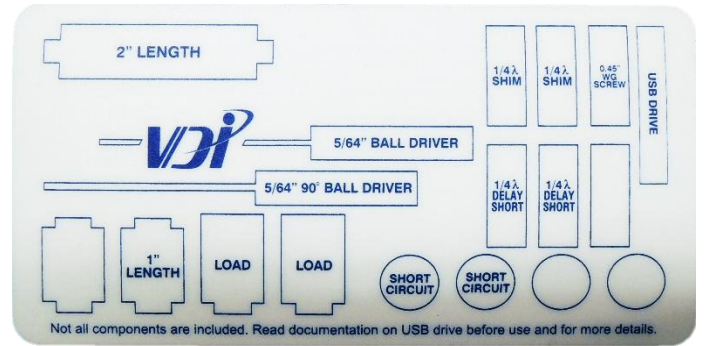

FIGURE 11: TYPE B TRL CALIBRATION KIT

Equipment typically supplied for Type A and Type B TRL calibration is shown at the left. This kit's label (above) is modified to reflect typical contents.

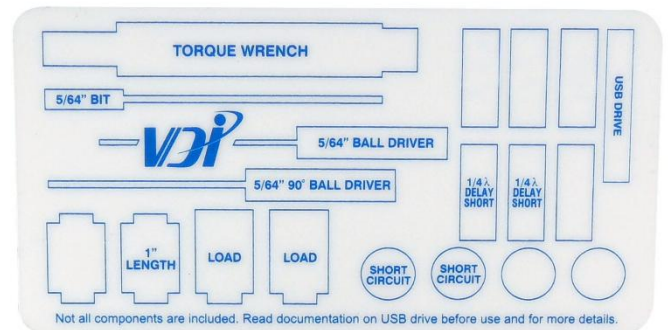

FIGURE 12: TYPE B SOLT CALIBRATION KIT

Equipment typically supplied for Type B SOLT calibration is shown at the left. This kit's label (above) is modified to reflect typical contents.



VNAX Type B Calibration Kit

VDI Part Number	Freq. Band (GHz)	Kit Type	Components List	Delay Length (one-way, in.±0.0002)	Cut-off Frequency (GHz)	Time Delay (one-way, ps)
WM250(WR1.0)CK	750 - 1,100	SOLT	2SC, 2LD, 1SW(1"), 1QD	0.0043	599.4	0.367
WM380(WR1.5)CK	500 - 750	SOLT	2SC, 2LD, 1SW(1"), 1QD	0.0063	394.3	0.534
WM570(WR2.2)CK†	330 - 500	SOLT	2SC, 2LD, 1SW(1"), 1QD	0.0094	262.9	0.801
WM710(WR2.8)CK	260 - 400	SOLT	2SC, 2LD, 1SW(1"), 1QD	0.0118	211.1	1.001
WR3.4CK	220 - 330	TRL	2SC, 2LD, 1SW(2"), 2QW	0.0142	173.4	1.201
WR4.3CK	170 - 260	TRL	2SC, 2LD, 1SW(2"), 2QW	0.0185	137.2	1.568
WR5.1CK†	140 - 220	TRL	2SC, 2LD, 1SW(2"), 2QW	0.0220	115.7	1.869
WR6.5CK	110 - 170	TRL	2SC, 2LD, 1SW(2"), 1QW	0.0287	90.76	2.436
WR8.0CK	90 - 140	TRL	2SC, 2LD, 1SW(2"), 1QW	0.0346	73.74	2.936
WR10CK†	75 - 110	TRL	2SC, 2LD, 1SW(2"), 1QW	0.0425	59.00	3.604
WR12CK†	60 - 90	TRL	2SC, 2LD, 1SW(2"), 1QW	0.0528	48.35	4.471
WR15CK†	50 - 75	TRL	2SC, 2LD, 1SW(2"), 1QW	0.0630	39.86	5.339
WR19CK*	40 - 60	TRL	2SC, 2LD, 1SW(2"), 1QW	0.0776	31.41	6.577
WR22CK*	33 - 50	TRL	2SC, 2LD, 1SW(2"), 1QW	0.0945	26.35	8.009
WR28CK*	26.5 - 40	TRL	2SC, 2LD, 1SW(2"), 1QW	0.1177	21.10	9.975

WR28 to WR12 Calibration Kits include 0.45" waveguide screws.

*WR28, WR22, and WR19 use a UG-599/U-M flange. Therefore, the form factor of the calibration kit components will be different than those of other calibration kits.

†VDI calibration kits supplied for each waveguide band will support calibration of the extended frequency ranges for that specific waveguide band.

Cal Kit Component Acronyms

SOLT: Short Open Load Through Calibration

TRL: Through Reflect Line Calibration

SC: Short Circuit

LD: Matched Load

SW(1"): 1-inch Straight Waveguide

SW(2"): 2-inch Straight Waveguide

QW: Quarter Wave Shim

QD: Quarter Wave Delayed Short

All Calibration Kits include a ball driver and Cal Kit definition file(s) on USB memory stick.

Calibration Kit Specification Updates

Check our website for the latest Calibration Kit updates: <https://vadiodes.com/en/resources/downloads>



VDI VNAX Cable Sets

VDI offers a variety of cable sets to facilitate Extension Module operation. These cable sets complement various configurations described in this manual and also are designed to provide optimal performance with most modern network analyzers. Please contact VDI for additional details or assistance with ordering.

Keysight VNAs

Cable Sets (CS) for Standard VNAX Modules			
	Module Configuration		
VNA Model / Length	TxRx	TxRef	Rx
Keysight N526xA Controller (Legacy) or Copper Mountain VNA + Booster Set			
1.2m	CS-TST-TxRxM-1.2	CS-TST-TxRefM-1.2	CS-TST-RxM-1.2
5m	CS-TST-TxRxM-5	CS-TST-TxRefM-5	CS-TST-RxM-5
Keysight N5292A Controller			
1.2m	N5290A304 (Contact Keysight)		
5m	Contact Keysight		
VNA with 3.5mm or 2.9mm Ports			
1.2m	CS-24-TxRxM-1.2	CS-24-TxRefM-1.2	CS-24-RxM-1.2
5m	CS-24-TxRxM-5	CS-24-TxRefM-5	CS-24-RxM-5
VNA with 2.4mm or 1.85mm Ports			
1.2m	CS-40-TxRxM-1.2	CS-40-TxRefM-1.2	CS-40-RxM-1.2
5m	CS-40-TxRxM-5	CS-40-TxRefM-5	CS-40-RxM-5
VNA with 2.4mm or 1.85mm Ports, WM164 modules			
1.2m	CS-40-TxRx-HL-1.2	CS-40-TxRef-HL-1.2	-

Notes:

TxRx = 2IF,LO,RF,Power; TxRef=IF,LO,RF,Power; Rx=IF,LO,Power.

TxRx-HL and TxRef-HL cable sets (for high-drive and low-drive) includes an additional RF cable with a 2.4mm(m) connector.

Cable connector type (VNA-side): Controller - IF-SMA(m), LO/RF-2.9mm(m); 3.5mm or 2.9mm VNA - IF-SMA(m), LO/RF-2.9mm(f); 2.4mm or 1.85mm VNA - IF-2.4mm(m), RF/LO - 2.4mm(f).

VDI modules must be configured for the proper cable length. VNAX Module with -5M option is required for longer cable configurations.

Intermediate cable lengths are available by special order with longer delivery time; contact VDI for details.



Other VNAs

Cable Sets (CS) for Standard VNAX Modules				
	Module Configuration			
VNA Model / Length	TxRx-TxRx	TxRx-Rx	TxRef-Rx	TxRx
ZVA / ZNA with 3.5mm or 2.9mm Ports				
1.2m	CS-24-ZVA1-1.2	CS-24-ZVA2-1.2	CS-24-ZVA3-1.2	CS-24-ZVA4-1.2
5m	CS-24-ZVA1-5	CS-24-ZVA2-5	CS-24-ZVA3-5	CS-24-ZVA4-5
ZVA / ZNA with 2.4mm or 1.85mm Ports				
1.2m	CS-40-ZVA1-1.2	CS-40-ZVA2-1.2	CS-40-ZVA3-1.2	CS-40-ZVA4-1.2
5m	CS-40-ZVA1-5	CS-40-ZVA2-5	CS-40-ZVA3-5	CS-40-ZVA4-5
Vector Star with 3739C Test Set				
1.2m	Contact Anritsu			
5m				

Notes:

TxRx = 2IF,LO,RF,Power; TxRef=IF,LO,RF,Power; Rx=IF,LO,Power.
 For two module configurations on the ZVA / ZNA, an LO splitter is included.

Cable connector type (VNA-side): 3.5mm or 2.9mm VNA - IF-SMA(m), LO/RF-2.9mm(f); 2.4mm or 1.85mm VNA - IF-2.4mm(m), RF/LO - 2.4mm(f). If LO splitter is included, RF/LO-2.9mm(m).

VDI modules must be configured for the proper cable length. VNAX Module with -5M option is required for longer cable configurations.

Intermediate cable lengths are available by special order with longer delivery time; contact VDI for details.



High Sensitivity Receiver Option

Standard Operation

The high sensitivity system can be used in a manner similar to a standard system by affixing the included waveguide attenuator to the Rx module. It is possible to perform a waveguide calibration using the system in this configuration. This configuration is used by VDI to characterize the performance of the Rx module.

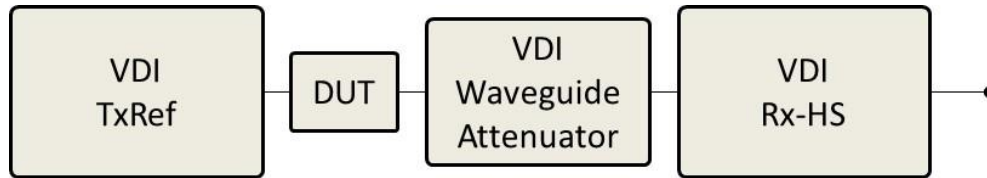
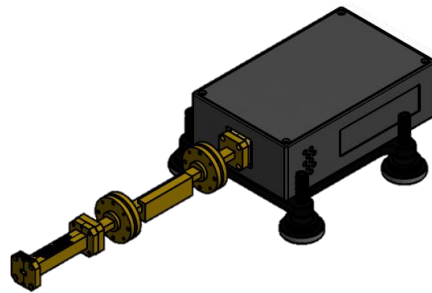

FIGURE 13: BLOCK DIAGRAM OF THE STANDARD OPERATION MODE OF A VDI RX MODULE

Note: For some Rx modules (e.g. WR-19), VDI may include more than one waveguide attenuator sections for use in ‘Standard Operation’. For these Rx modules, all included attenuators must be used for Standard Operation to avoid compression or damage of the Rx module. See picture below.



High Sensitivity Operation

To use the system for maximum sensitivity capability, the included waveguide attenuator should not be utilized in the test setup. Verify that the loss of the DUT is high enough to avoid damage or saturation of the VDI Rx Module. For best results the output signal should be amplified but should not exceed the saturation limit of the measurement device. Please contact VDI with any questions before configuring your Extension Module for high sensitivity operation.

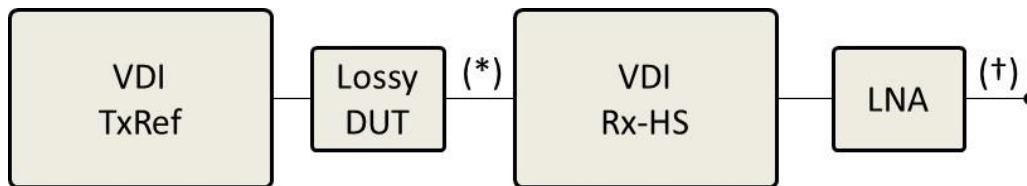

FIGURE 14: BLOCK DIAGRAM OF HIGH SENSITIVITY OPERATION MODE

*See RF Drive Limit labels for the Rx module

†Amplify signal for maximum sensitivity



Enhanced / Effective Dynamic Range for Receivers

High Sensitivity Receiver Modules

VDI Extension Modules can be optimized for high loss DUTs such as antenna ranges and lossy wafer probes. This configuration takes advantage of the high sensitivity inherent in our receiver modules to allow for up to 160 dB of enhanced dynamic range, overcoming up to 40 dB of path loss in the measurement.

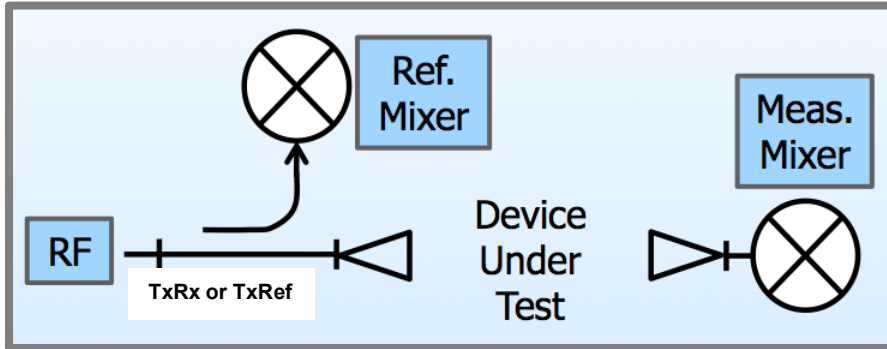
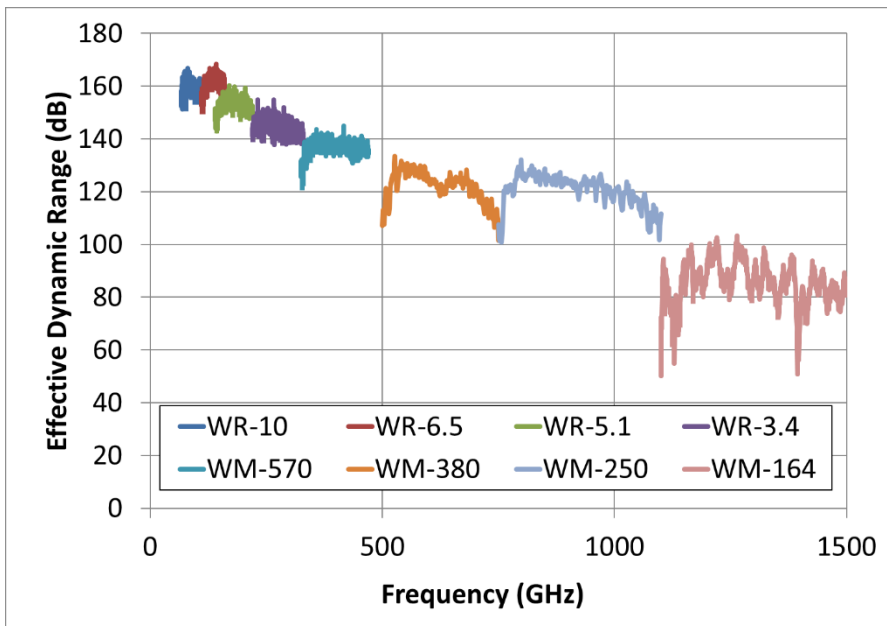

FIGURE 15: A TYPICAL ENHANCED S₂₁ CONFIGURATION CONSISTS OF ONE HIGH POWER TxREF MODULE ON PORT 1 AND A HIGH SENSITIVITY RX MODULE (Rx-HS) ON PORT 2

Technical Note: Measurement of dynamic range is often limited by receiver saturation, rather than transmitter power. For lossy samples, saturation is alleviated, allowing use of greater Tx power and/or higher Rx sensitivity.



Cable Loss Characterization

AccuTest 150 Attenuation Data

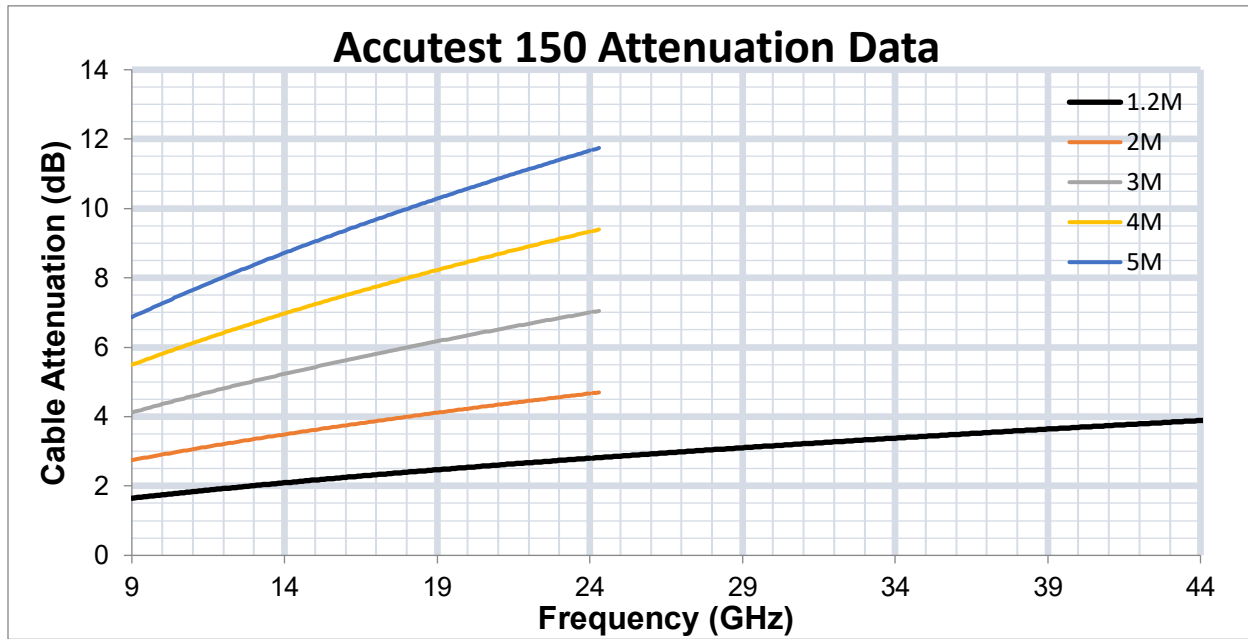

FIGURE 16: INSERTION LOSS OF ACCUTEST 150 (RF/LO CABLE) WITH RESPECT TO FREQUENCY. THIS CHART CAN BE USED TO CALCULATE CABLE LOSSES IN YOUR SYSTEM



Mechanical Drawings

Precision Calibration Shim (WR15 and Higher Frequency)

THE INFORMATION CONTAINED IN THIS DOCUMENT IS THE PROPRIETARY PROPERTY OF VIRGINIA DIODES, INC.

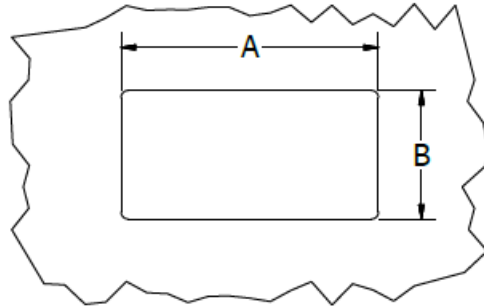

WAVEGUIDE TABLE			
DIMENSION	- A -	- B -	- T -
WR-15	0.1480 in	0.0740 in	0.0630 in
WR-12	0.1220 in	0.0610 in	0.0528 in
WR-10	0.1000 in	0.0500 in	0.0425 in
WR-8.0	0.0800 in	0.0400 in	0.0346 in
WR-6.5	0.0650 in	0.0325 in	0.0287 in
WR-5.1	0.0510 in	0.0255 in	0.0220 in
WR-4.3	0.0430 in	0.0215 in	0.0185 in
WR-3.4	0.0340 in	0.0170 in	0.0142 in
WM-710 (WR-2.8)	0.0280 in	0.0140 in	0.0118 in
WM-570 (WR-2.2)	0.0224 in	0.0112 in	0.0094 in
WM-470 (WR1.9)	0.0185 in	0.0093 in	0.0079 in
WM-380 (WR1.5)	0.0150 in	0.0075 in	0.0063 in
WM-310 (WR-1.2)	0.0122 in	0.0061 in	0.0051 in
WM-250 (WR-1.0)	0.0098 in	0.0049 in	0.0043 in
WM-200 (WR-0.8)	0.0079 in	0.0039 in	0.0035 in
WM-164 (WR-0.65)	0.0065 in	0.0032 in	0.0028 in
WM-130 (WR-0.51)	0.0051 in	0.0026 in	0.0024 in
WM-106 (WR-0.43)	0.0042 in	0.0021 in	0.0020 in
WM-86 (WR-0.34)	0.0034 in	0.0017 in	0.0016 in

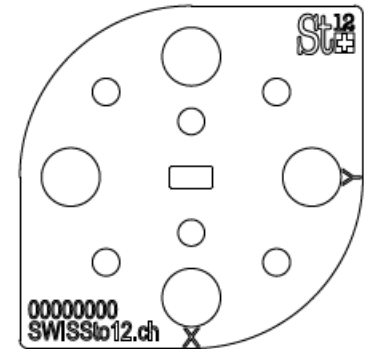
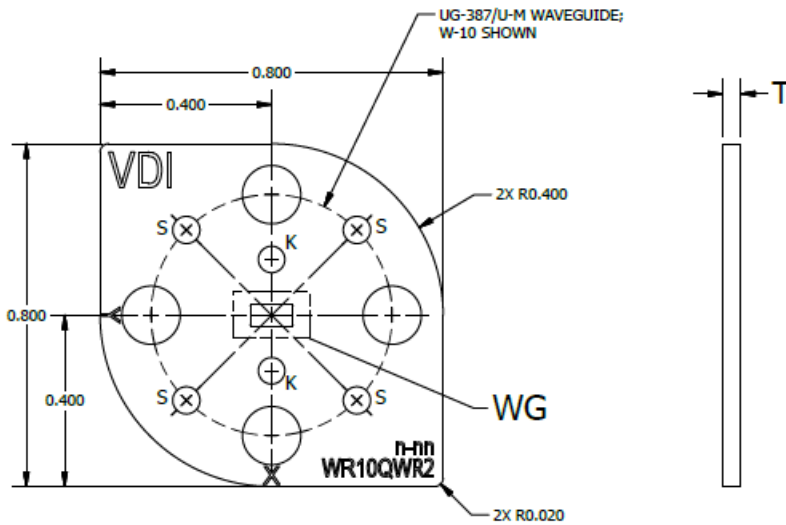

NOTE: SPECIFICATIONS AND CHARACTERISTICS ARE TYPICAL AND SUBJECT TO CHANGE AT ANY TIME.

TITLE: PRECISION CALIBRATION SHIM (QW)	MATERIAL:	
MODEL #: WR-10QW	LAST REV. DATE: 7/28/2014	SHEET: 1 OF 1
	LAST REV.: R3V1	UNITS: INCH



ORIGINAL DRAWING BY: C. NEFF
SEGARS ENGINEERING for:

VIRGINIA DIODES, INC.
979 2nd ST. SE, SUITE 309
CHARLOTTESVILLE, VA 22902
PHONE: 434.297.3257
FAX: 434.297.3258
www.virginiadiodes.com



Precision Calibration Shim (WR28 to WR19)

THE INFORMATION CONTAINED IN THIS DOCUMENT IS THE PROPRIETARY PROPERTY OF VIRGINIA DIODES, INC.

SHIM DIMENSION TABLE				
WAVEGUIDE	- A -	- B -	- T -	PART NUMBER MARKING
WR-28	0.2800	0.1400	0.1177	WR28QWR1
WR-22	0.2240	0.1120	0.0945	WR22QWR1
WR-19	0.1880	0.0940	0.0776	WR19QWR1

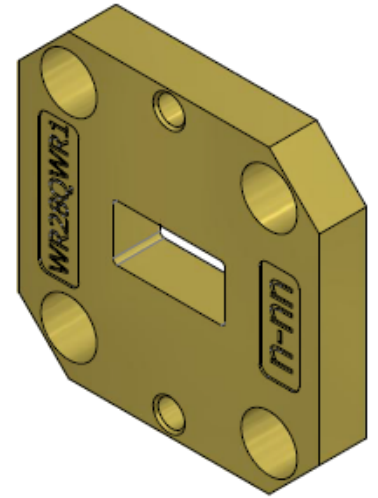
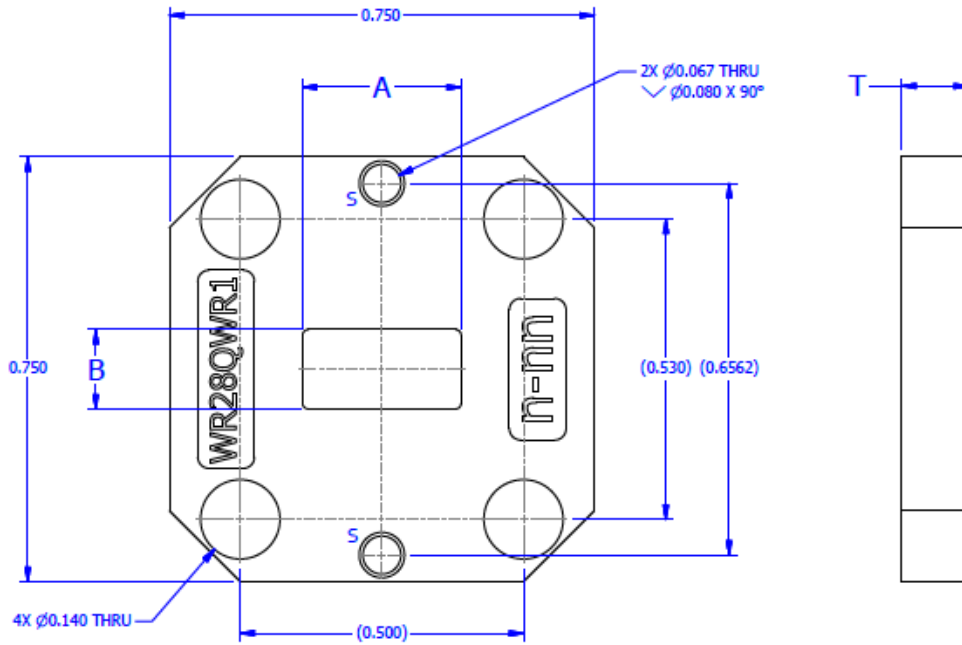

NOTE: SPECIFICATIONS AND CHARACTERISTICS ARE TYPICAL AND SUBJECT TO CHANGE AT ANY TIME.

TITLE:
MILLED CALIBRATION SHIM
WR-19, WR-22, & WR-28

MODEL #:
WR28QW (SHOWN)

MATERIAL:
ALUMINUM ALLOY (MAY BE GOLD PLATED)

LAST REV. DATE:
5/10/2018

LAST REV.:
R1V2

SHEET:
1 OF 1

UNITS:
INCH



ORIGINAL DRAWING BY: C. NEFF
SEGARS ENGINEERING for:

VIRGINIA DIODES, INC.
979 2nd ST. SE, SUITE 309
CHARLOTTESVILLE, VA 22902
PHONE: 434.297.3257
FAX: 434-297-3258
www.virginiadiodes.com



Precision Calibration Delay

THE INFORMATION CONTAINED IN THIS DOCUMENT IS THE PROPRIETARY PROPERTY OF VIRGINIA DIODES, INC.

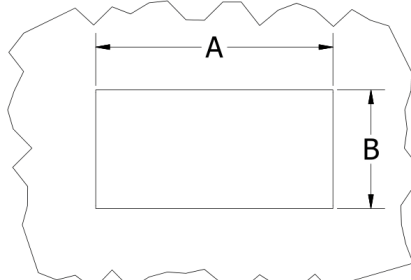
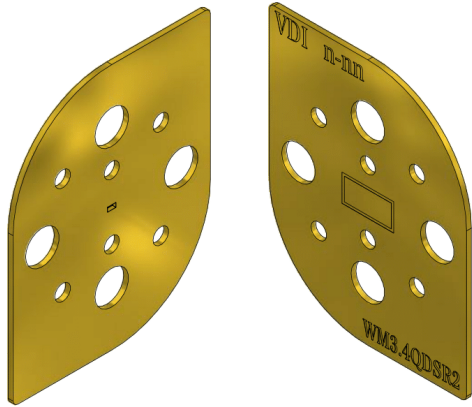

DIMENSION	WAVEGUIDE TABLE		
	- A -	- B -	- D -
WR-3.4	0.0340 in	0.0170 in	0.0142 in
WM-710 (WR-2.8)	0.0280 in	0.0140 in	0.0118 in
WM-570 (WR-2.2)	0.0224 in	0.0112 in	0.0094 in
WM-470 (WR1.9)	0.0185 in	0.0093 in	0.0079 in
WM-380 (WR1.5)	0.0150 in	0.0075 in	0.0063 in
WM-310 (WR-1.2)	0.0122 in	0.0061 in	0.0051 in
WM-250 (WR-1.0)	0.0098 in	0.0049 in	0.0043 in
WM-200 (WR-0.8)	0.0079 in	0.0039 in	0.0035 in
WM-164 (WR-0.65)	0.0065 in	0.0032 in	0.0028 in
WM-130 (WR-0.51)	0.0051 in	0.0026 in	0.0024 in
WM-106 (WR-0.43)	0.0042 in	0.0021 in	0.0020 in
WM-86 (WR-0.34)	0.0034 in	0.0017 in	0.0016 in

DETAIL WG - 20X SCALE

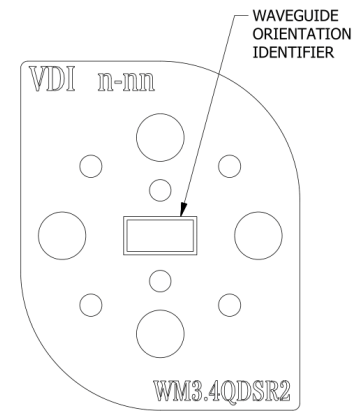
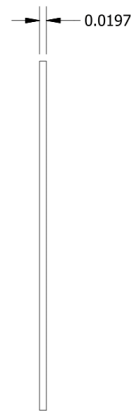
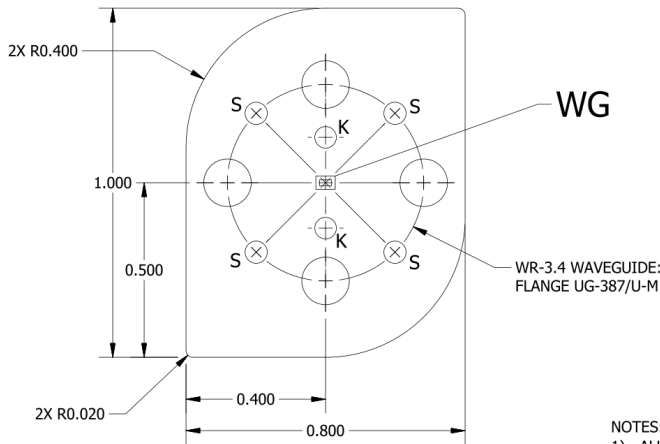

- NOTES:
 1) ALL DIMENSIONS IN INCHES, UNLESS NOTED OTHERWISE.
 2) WM-3.4QDS SHOWN (FOR REFERENCE ONLY).

ORIGINAL DRAWING BY: C. NEFF
 SEGARS ENGINEERING for:

VIRGINIA DIODES, INC.
 979 2nd ST. SE, SUITE 309
 CHARLOTTEVILLE, VA 22902
 PHONE: 434.297.3257
 FAX: 434-297-3258
 www.virginiadiodes.com

NOTE: SPECIFICATIONS AND CHARACTERISTICS ARE TYPICAL AND SUBJECT TO CHANGE AT ANY TIME.

TITLE:
**PRECISION CALIBRATION
 DELAY (QDS)**

MODEL #:
 WR3.4QDS (SHOWN)

MATERIAL:
 SEE P.O.

LAST REV. DATE:
 7/21/2016

LAST REV.:
 R2V3

SHEET:
 1 OF 1

UNITS:
 INCH



VDI-175 Power Supply Specifications

VDI-175 Power Supply Specifications

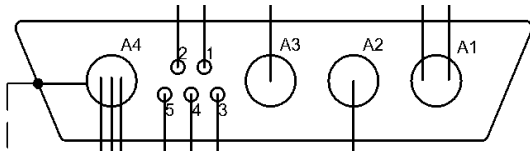

VDI-175 Output Connector shown

Parameter	Pin(s)	Specifications
DC Output	1	-5VDC/1A
	2	NC
	3	+5VDC/1A (Fan)
	4	GROUND (Fan)
	5, A4	GROUND
	A1	+12VDC/11A
	A2	+5VDC/7A
	A3	+15VDC/3A
Maximum Output Power	--	175W
AC Input	--	100-240VAC/ 3.5A
	--	50-60Hz

LEMO (10-Pin, 2B) Cable Specifications

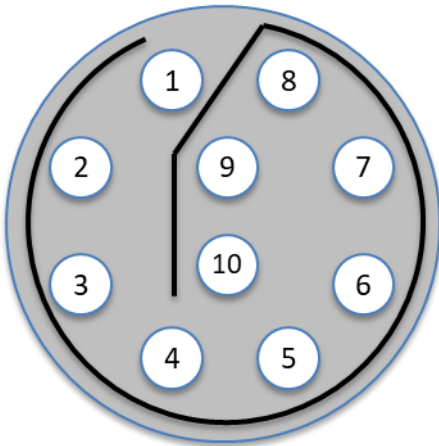

Male LEMO Connector shown

DB9-4 Pin	LEMO Pin	V _{DC} (V)	I _{DC} (A)
1	1	-5	1
2	2	NC	
A1	3	+12	11
A1	4		
A3	5	NC	
A4	6	GRND	-
A2	7	+5	7
3	8	+5 (Fan)	1
4	9	GRND (Fan)	-
5	10	GRND	-



Waveguide Clamps

Waveguide Clamp Precautions

Waveguide clamps can be used to reduce calibration and testing time. The picture below shows an example of a waveguide clamp being used on a pair of VDI VNAX modules during a calibration step. Using the waveguide clamp requires more careful attention to waveguide / test port alignment. VDI recommends that the two VNAX test ports can be pushed together with very little mechanical resistance. Any mechanical resistance indicates some degree of mechanical misalignment. Without proper alignment, poor calibration quality is expected. For a waveguide clamp quote, please contact VDI.

