



W-Band Transmitter, 90 to 96 GHz, 30 dB Gain, +20 dBm P_{-1dB}, Image Rejection

Description:

Model SST-9330632030-10-M1-I is a W-Band image rejected transmitter. The transmitter has a typical conversion gain of 30 dB with a typical IF input power of -20 dBm in the frequency range of 5 to 11 GHz and a RF output frequency range of 90 to 96 GHz. The transmitter has a built-in x8 multiplier, which requires a typical input LO power and frequency of 0 dBm and 10.625 GHz, respectively. With the built-in IF hybrid, the receiver typically offers a 20 dB image rejection level. The LO and IF port are equipped with female SMA connectors and the RF port is a WR-10 waveguide with a UG-387/U-M flange.



Features:

- Compact Size
- High Transmitting Power
- Fully Integrated Module

Applications:

- Radar Systems
- Communication Systems

Electrical Specifications:

Parameter	Minimum	Typical	Maximum
RF Output Frequency	90 GHz		96 GHz
IF Input Frequency	5 GHz	8 GHz	11 GHz
IF Input Power		-20 dBm	+7 dBm
Image Rejection		20 dB	
RF to IF Conversion Gain		30 dB	
RF Output P-1 dB/Psat		+20/+24 dBm	
LO Frequency		10.625 GHz	
LO Input Power		0 dBm	+10 dBm
LO DC Voltage Supply	+6 V _{DC}	+8 V _{DC}	+16 V _{DC}
LO Current Supply		750 mA	
Specification Temperature		+ 25 °C	
Operating Temperature	0 °C		+ 50 °C

Mechanical Specifications:

Item	Specification
RF Port	WR-10 Waveguide with UG387/U-M Flange
IF Port and LO Port	SMA(F) and SMA (F)
Bias Port	SMA (F)
Case Material/Plating	Aluminum/Gold Plated
Weight	2.0 Oz
Size	1.10" (W) X 1.80" (L) X 0.50" (H)
Outline	ST-SW

www.sagemillimeter.com | 3043 Kashiwa Street, Torrance, CA 90505
 Phone: 424-757-0168 | Fax: 424-757-0188 | Email: sales@sagemillimeter.com



W-Band Transmitter, 90 to 96 GHz, 30 dB Gain, +20 dBm P_{-1dB}, Image Rejection

Block Diagram:

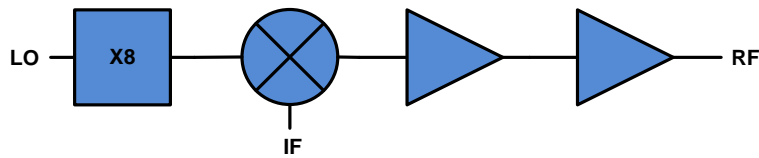

Typical Conversion Gain vs. Frequency

Bias: +8 V_{DC}/660 mA, LO: 11 GHz/0 dBm

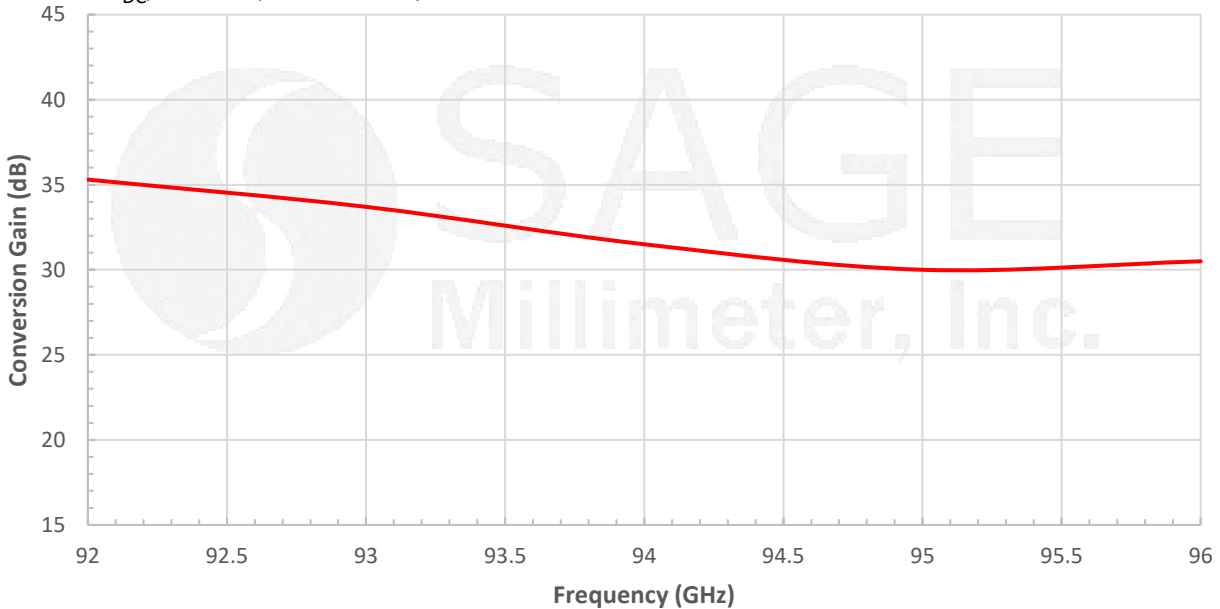

Output Power vs. Frequency

Bias: +8 V_{DC}/660mA, LO: 11 GHz/0 dBm

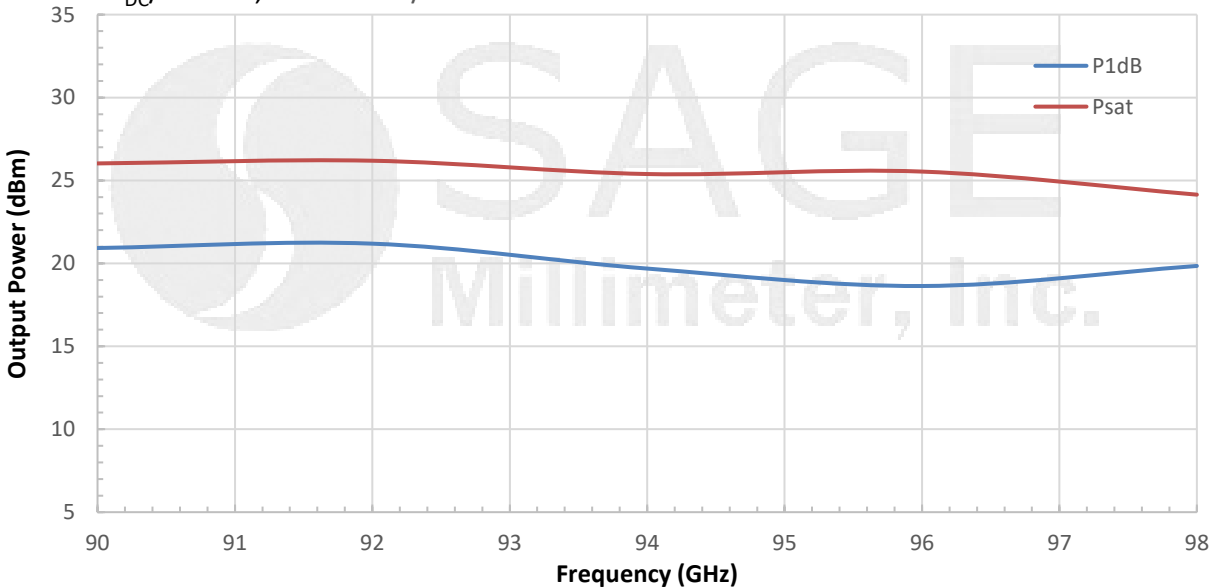

W-Band Transmitter, 90 to 96 GHz, 30 dB Gain, +20 dBm P_{-1dB}, Image Rejection

Mechanical Outline: (Unless otherwise specified, all dimensions are in inches [millimeters])

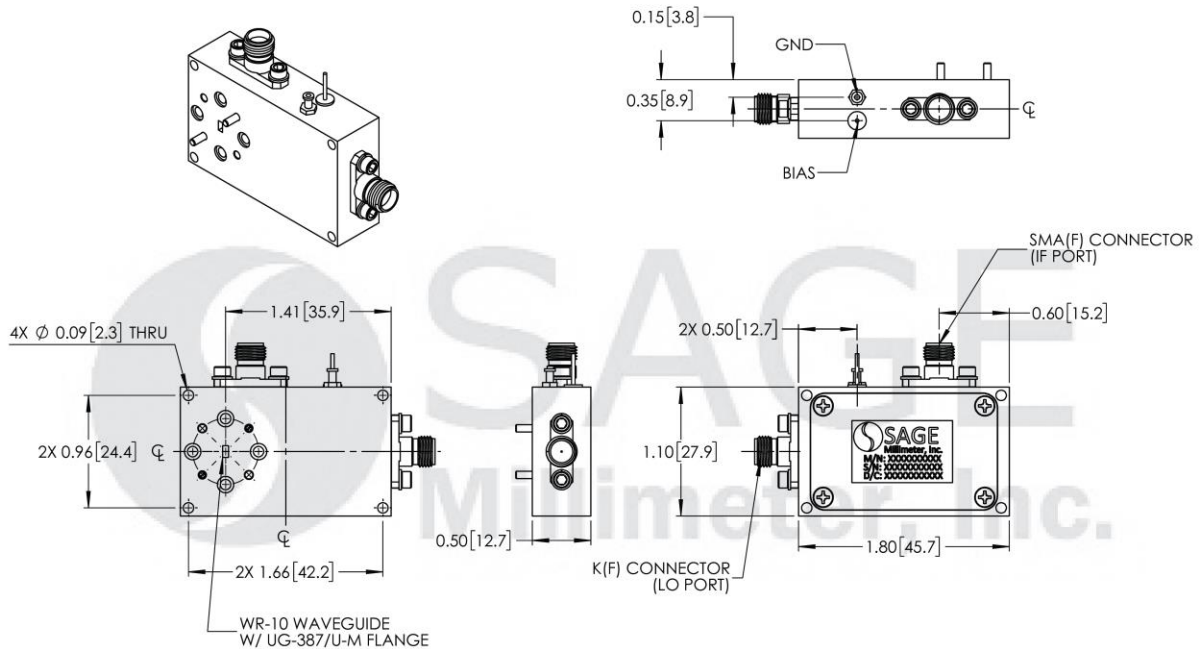

Note:

- All data presented is collected from a sample lot. Actual data may vary unit to unit.
- All testing was performed under +25 °C case temperature.
- SAGE Millimeter, Inc. reserves the right to change the information presented without notice.
- Other mechanical configurations are available under different model numbers.

Caution:

- Exceeding absolute maximum ratings shown will damage the device.
- The device is static sensitive. Always follow ESD rules when working with the device.
- The case temperature of the device shall never exceed +50 °C. Use proper heatsink or fan if necessary.