



## W-Band Downconverter, 75 to 110 GHz, 5 dB Gain

### Description:

**Model STC-75311405-10-C1** is a W-Band down-converter that converts millimeterwave signals from the frequency range of 75 to 110 GHz to the baseband at 6 to 41 GHz. The down-converter has a built-in phase locked oscillator (PLO), which is externally referenced at 10 MHz. The down converter also integrates a PIN diode based SPDT switch at the RF input for bypassing in order to monitor the receiving signal level. The switch is controlled by TTL signal and the bypassing “on” is at TTL “high.” The bypassing loss is 4 dB typical and 6 dB maximum. The RF ports for the downconverter is WR-10 waveguides with UG-387/U-M flange. The IF output is a K(F) connector and PLO reference signal input connector is an SMA (F) connector. A wall mount AC adapter is included for AC powering.



### Features:

- Full Waveguide Band Coverage
- High IF Frequency Range

### Applications:

- Test Lab
- Instrumentations
- Auto Test Set

### Electrical Specifications:

Parameter	Minimum	Typical	Maximum
RF Input Frequency	75 GHz		110 GHz
IF Frequency Output	6 GHz		41 GHz
Conversion Gain	-1 dB	5 dB	13 dB
Combined Harmonic Power			-70 dBm
Spurious			-40 dBc
Noise Figure		10 dB	15 dB
Bypass Insertion Loss		4 dB	6 dB
Bypass “on”		TTL “Low”	
TTL Low	0 V <sub>DC</sub>		+ 0.8 V <sub>DC</sub>
TTL High	+2.7 V <sub>DC</sub>		+5.0 V <sub>DC</sub>
Switch Isolation	15 dB	20 dB	
Input P <sub>1dB</sub>	-20 dBm		
Reference Frequency		10 MHz	
Reference Input Power	-5 dBm	+3 dBm	
Reference Damage Level			+10 dBm
RF Damage Level			-15 dBm
Return Loss		10 dB	
Bias Voltage	+8 V <sub>DC</sub>	+12 V <sub>DC</sub>	+15 V <sub>DC</sub>
Bias Current		750 mA	
Specification Temperature		+25 °C	
Operating Temperature	+0 °C		+50 °C





## W-Band Downconverter, 75 to 110 GHz, 5 dB Gain

### Mechanical Specifications:

Item	Specification
RF Input/ Output Ports	WR-10 Waveguide with UG-387/U-M Flange
10 MHz Reference Port	SMA (F)
IF Port	K (F)
Bias Port	2.5mm DC Jack
Finish	Black Anodized
Weight	3.2 Lbs
Size	10.83" (L) x 6.15" (W) x 3.34" (H)
Outline	TK-TC-W-CR3

### Typical Gain and Noise Figure vs. Frequency

Bias: +12 V<sub>DC</sub>/750 mA; RF: -40 dBm

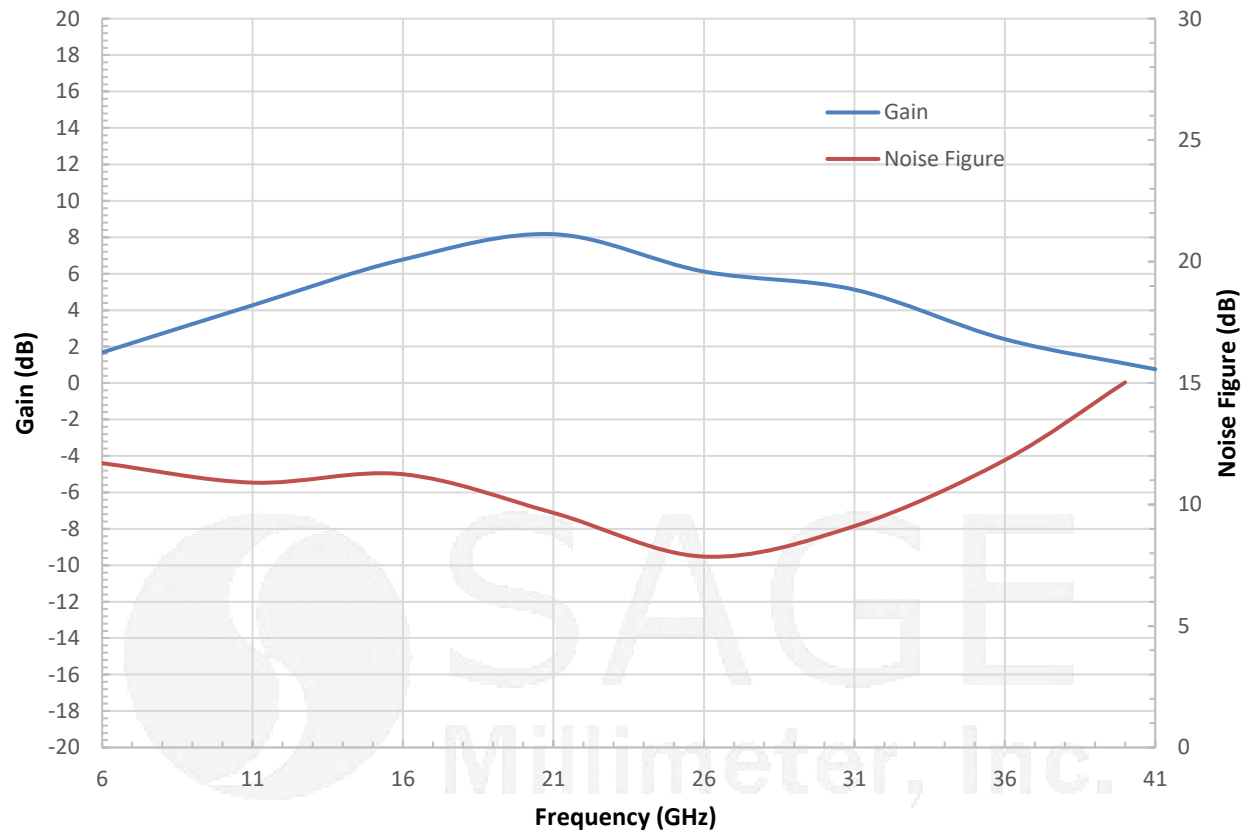



## W-Band Downconverter, 75 to 110 GHz, 5 dB Gain

### Block Diagram:

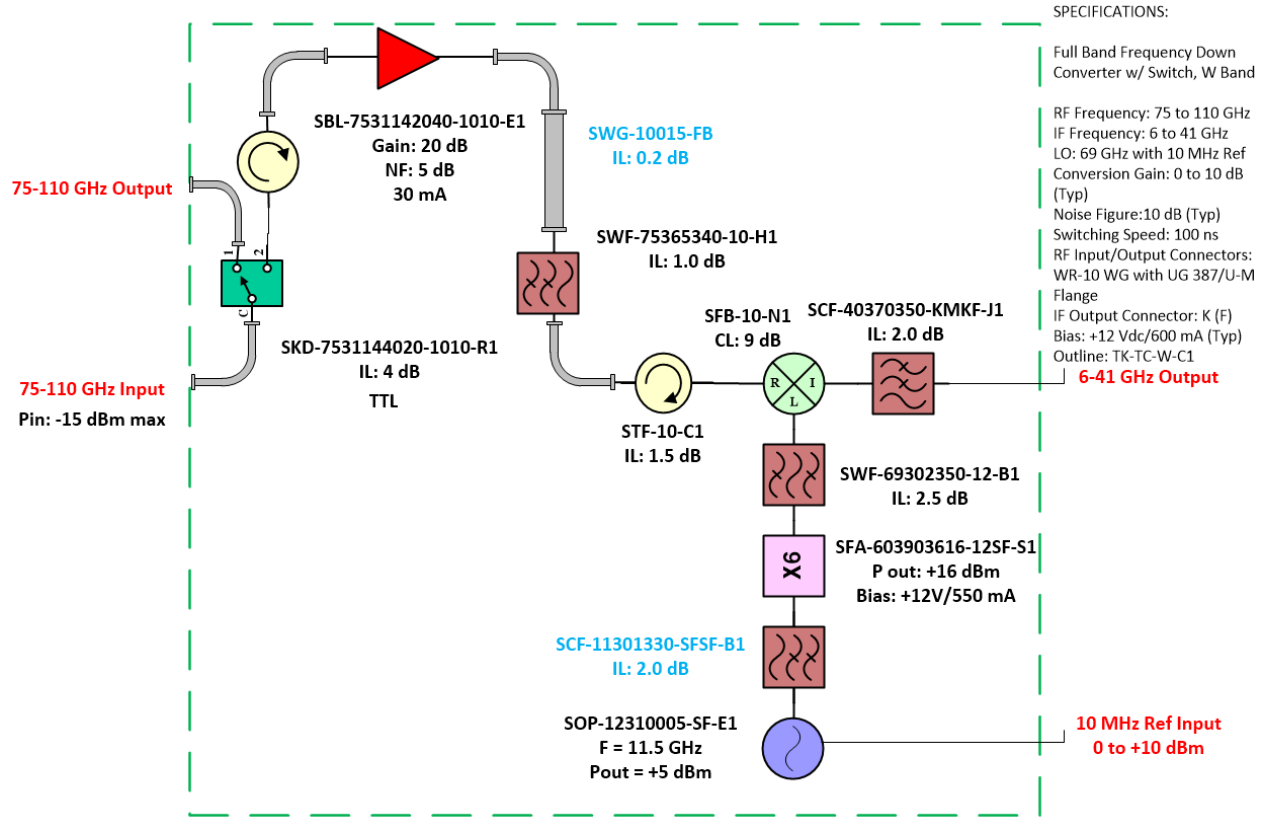

### Mechanical Outline: (Unless otherwise specified, all dimensions are in inches [millimeters])

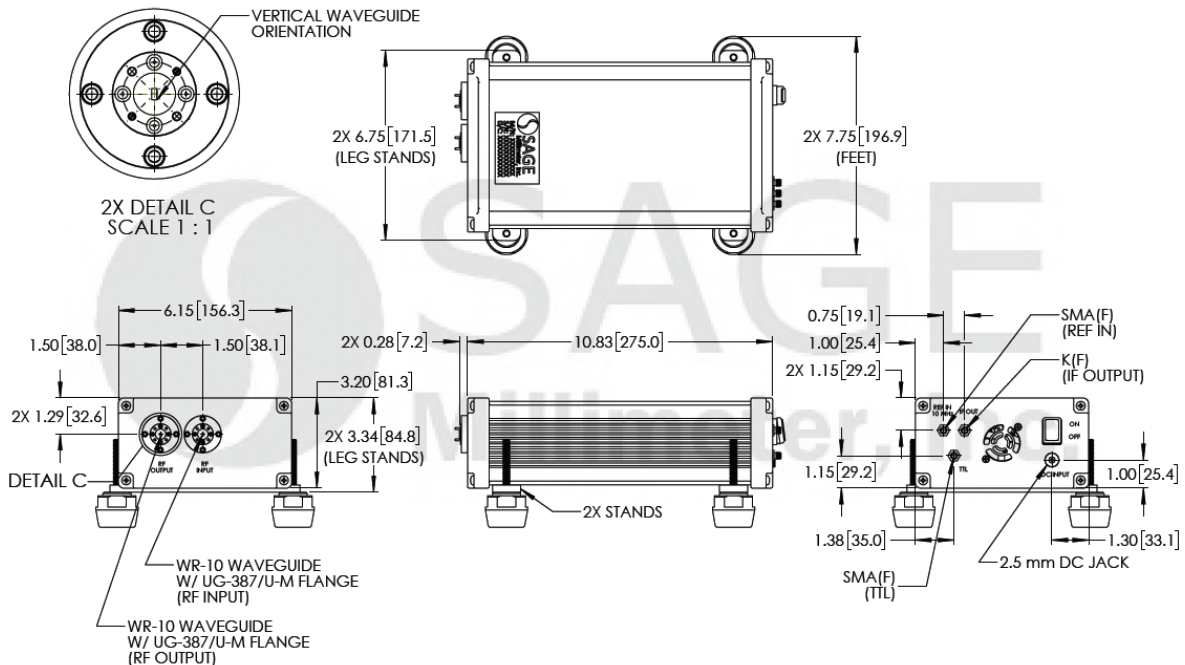

www.sagemillimeter.com | 3043 Kashiwa Street, Torrance, CA 90505  
 Phone: 424-757-0168 | Fax: 424-757-0188 | Email: sales@sagemillimeter.com



## W-Band Downconverter, 75 to 110 GHz, 5 dB Gain

### Note:

- All data presented is collected from a sample lot. Actual data may vary unit to unit.
- All testing was performed under +25 °C case temperature.
- The wall mount AC power adapter is included. The unit can be AC powered in the range of 88 to 240 V<sub>AC</sub>.
- SAGE Millimeter, Inc. reserves the right to change the information presented without notice.

### Caution:

- Exceeding absolute maximum ratings of the device will damage the device.
- Proper torque, 8.0 ± 0.15 inch-pounds (0.90 ± 0.02 Nm), should be applied. **SAGE Millimeter torque wrench, model SCH-08008-S1, is highly recommended.**
- Any foreign objects in the waveguide will degrade performance and may damage the device.

