

Tunable Differential Limiter

DLM-10SM

The DLM-10SM is a tunable, dual channel GaAs Schottky diode signal limiter featuring excellent IP3, insertion loss, and return loss. The limiting level is adjustable with an off-chip bias network, and the two channels can be used for differential or single-ended signals. The DLM-10SM is available in a lead-free, RoHS compliant QFN surface mount package and is compatible with standard leaded and lead-free PCB reflow soldering processes. The DLM-10SM is a superior alternative to discrete diode limiting options.



Features

- Industry leading IP3, low insertion loss, and return loss
 - Adjustable limiting level with off-chip bias network
 - Single channel differential/Dual channel single ended
 - RoHS Compliant

Electrical Specifications – Specifications guaranteed from -55 to +100°C, measured in a 50Ω system.

Parameter	Frequency Range (GHz)	Input Power (dBm)	Min	Typ	Max
Insertion Loss, Grounded Bias (dB)	DC - 10	-10		0.75	1.5
		+10		1.4	
		+15		3.75	
Input 1dB Compression, Grounded Bias (dBm)				10	
Return Loss, Grounded Bias (dB)		-10 to +9		20	
		+12		15	
Group Delay (ps)				260	

Model Number	Description
DLM-10SM	Differential Tunable Limiter in 3mm QFN
EVAL-DLM-10	Connectorized Eval Board, SMA-F

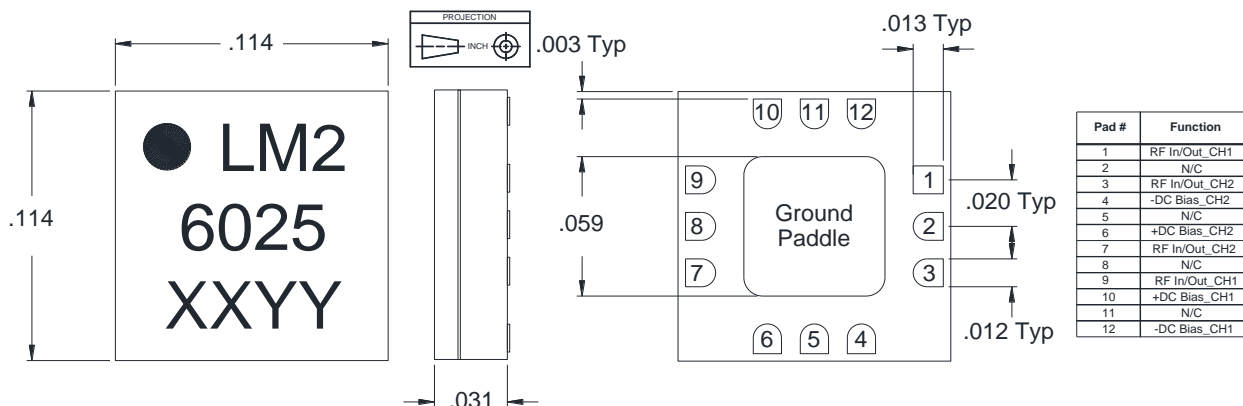

Tunable Differential Limiter

DLM-10SM

Page 2

Block Diagram

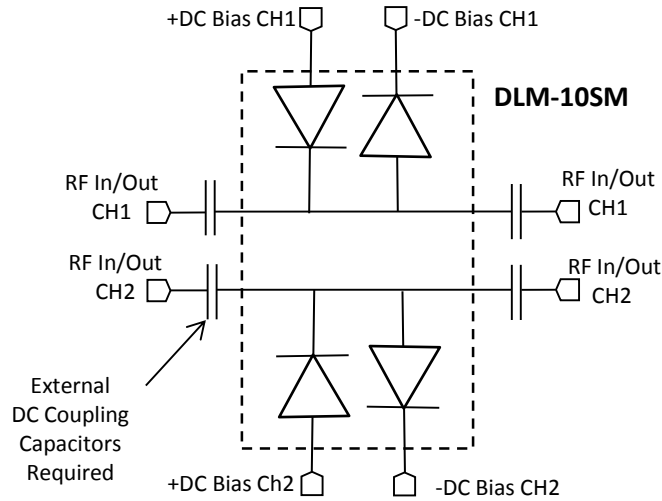

Typical Performance

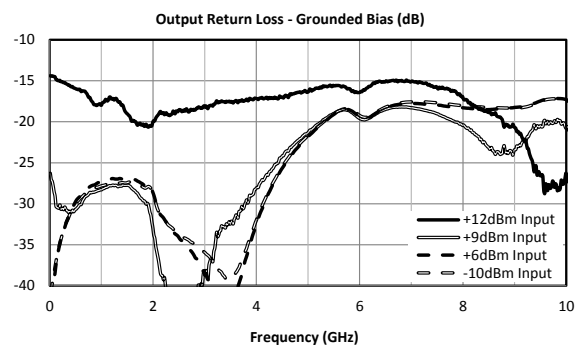
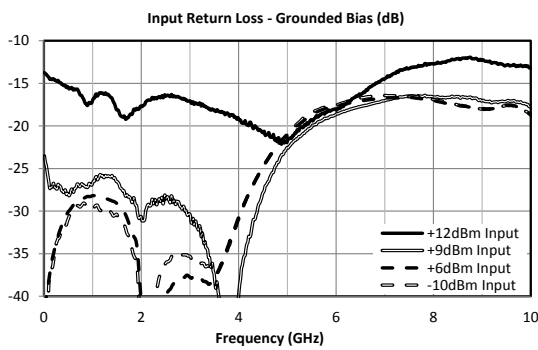
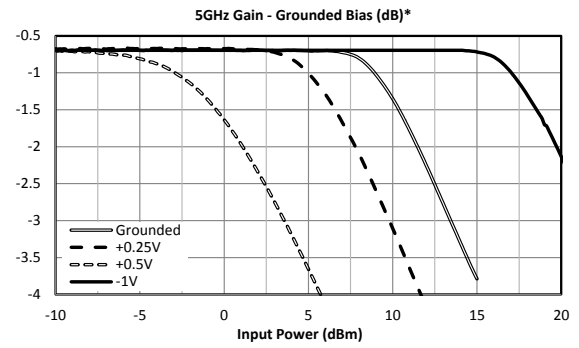
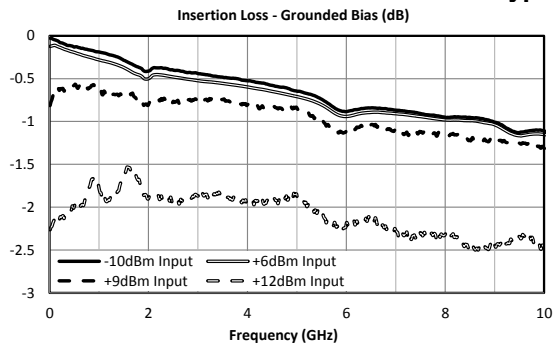

Tunable Differential Limiter

DLM-10SM

Page 3

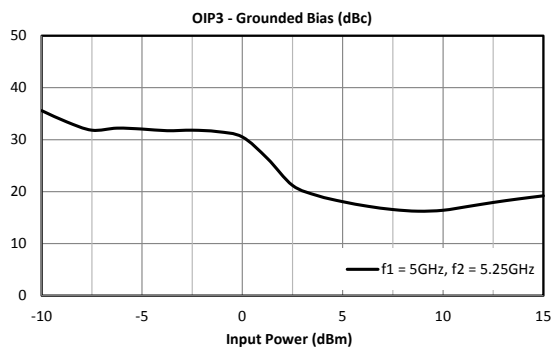
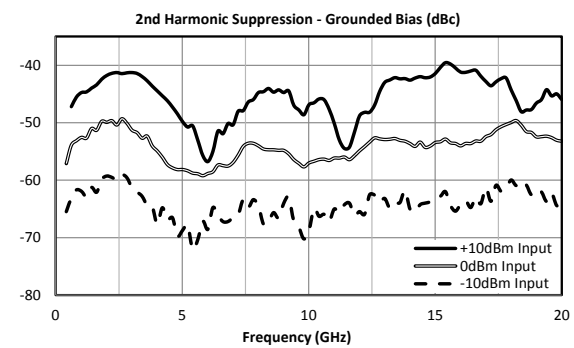
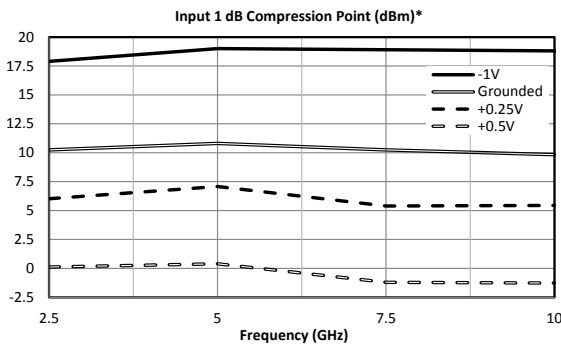
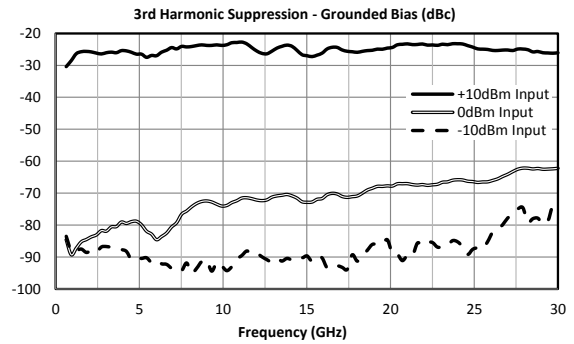
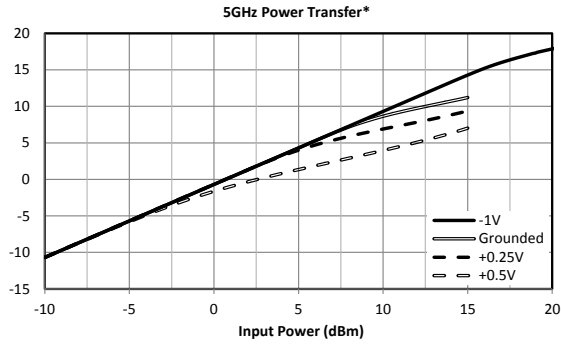

Tunable Differential Limiter

DLM-10SM

Page 4

Example Application Circuit

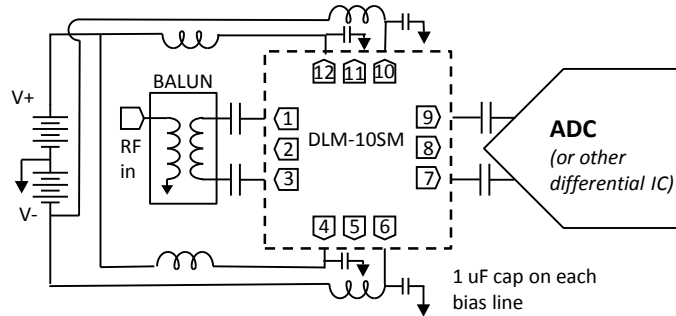

Differential/Two Channel Operation – The two limiting channels are not coupled together, so the device can be used as a single channel, two channel, or differential limiter. If the second channel is not used, it should be connected to RF ground.

Grounded Operation – Pins 4,6, 10, and 12 can be connected directly to RF/DC ground for ease of use. This will give a limiting level of around 7 dBm. If a higher or lower limiting level is desired, please see biased operation.

Biased Operation – For lower limiting levels, the internal diodes can be slightly forward biased to decrease the threshold voltage. A positive voltage should be applied to Pins 12 and 4, and an equal negative voltage should be applied to pins 6 and 10 for symmetric limiting. To increase the limiting threshold, the diodes should be reversed biased. This means that a negative voltage should be applied to pins 12 and 4, and an equivalent positive voltage should be applied to pins 6 and 10.

Biasing Circuitry – A voltage/current source that can both source and sink current must be used. Many voltage leveling circuits can only supply current to set a *minimum* voltage. In this case the signal will cause the diodes to self-bias in limiting operation, increasing the bias threshold. The bias supply must be able to sink current to prevent self-biasing. A low impedance RF ground must be provided by bypass capacitors to ground as close as possible to the bias pins. High frequency bypass capacitors are included on chip, so only low frequency (~1uF) capacitors are necessary. The DC power supply should be decoupled from the limiter circuit through an RF choke and decoupling capacitors if necessary to eliminate power supply noise.

Absolute Maximum Ratings	
Parameter	Maximum Rating
Forward Bias Voltage	0.5 V
Reverse Bias Voltage	4 V
Maximum Input Power	+27 dBm
ESD (Human Body Model)	Class 1A
Operating Temperature	-55°C to +85°C
Storage Temperature	-65°C to +150°C

NOTE:

Specifications are subject to change without notice. Contact Marki Microwave for the most recent specifications and data sheets.

Revision History

Revision Code	Revision Date	Comment
-	January 2017	Initial Release
A	May 2019	Added Max Power Handling, Updated ESD rating

Marki Microwave reserves the right to make changes to the product(s) or information contained herein without notice. Marki Microwave makes no warranty, representation, or guarantee regarding the suitability of its products for any particular purpose, nor does Marki Microwave assume any liability whatsoever arising out of the use or application of any product.

www.markimicrowave.com